

18" STARSHIP

Exterior Photoetched Enhancement Set

PGMS
ParaGrafix
Modeling Systems

INTRODUCTION:

Thank you for purchasing ParaGrafix's 18" Starship Exterior Photoetched Enhancement Set. The details in this set add a new level of realism to this venerable kit. For extra detail, consider our photoetched Shuttle Bay, p/n PGX108.

We have taken great care to ensure that most of the details included with this set can be used without any special skills beyond those normally needed for modeling. There are three exceptions: the bridge, the warp engine "rotors" and the primary hull "triangles". The bridge needs to be folded and the triangles will have to be annealed so that they are soft enough to conform to the shape of the hull.

For more information about working with photoetched parts, read the basic primer at: http://www.starshipmodeler.com/tech/jl_pe.htm and other resources available on the web.

TIPS:

The step numbers listed are purely suggestions. You can add parts in whatever order works best for the construction method you're using.

To cut the individual pieces from the fret, place the etch on a piece of a glass cutting board (or sheet of tempered glass) and cut through using a flat hobby knife. I prefer Xacto's small-sized chisel blade, # 17, ground with a slight curve.

Glass is important - use of a "self healing" cutting pad will result in bent pieces as the board flexes. If using plain glass instead of a cutting board it is important that you use tempered glass to avoid breakage.

ADDITIONAL MATERIALS:

Cyanoacrylate adhesive (aka CA or super glue) is the best option for bonding pieces together and to the Enterprise herself.

You may also want to have a small sheet of 0.02" (0.5mm) plastic on hand. This will help hold the warp engine grills (parts 1) in place.

PART ONE: THE BRIDGE

NOTES: The bridge will need to be painted before installation. The area around the bridge inside the primary hull should be painted black. The openings in part 12 allow you to light the bridge.

Cut a 3/8" (9.5mm) or greater diameter hole in the center of the bridge opening. The light shield (part 7) will provide a clean, circular edge to the hole once installed.

Fold the main bridge (part 13) so that the consoles are parallel to the floor and the ends fold down to hold them in place. Glue the main bridge, bridge base (part 12), and the light shield in place as shown. Make sure that the holes in the light shield line up with the holes in the kit piece so that the bridge dome can be properly attached.

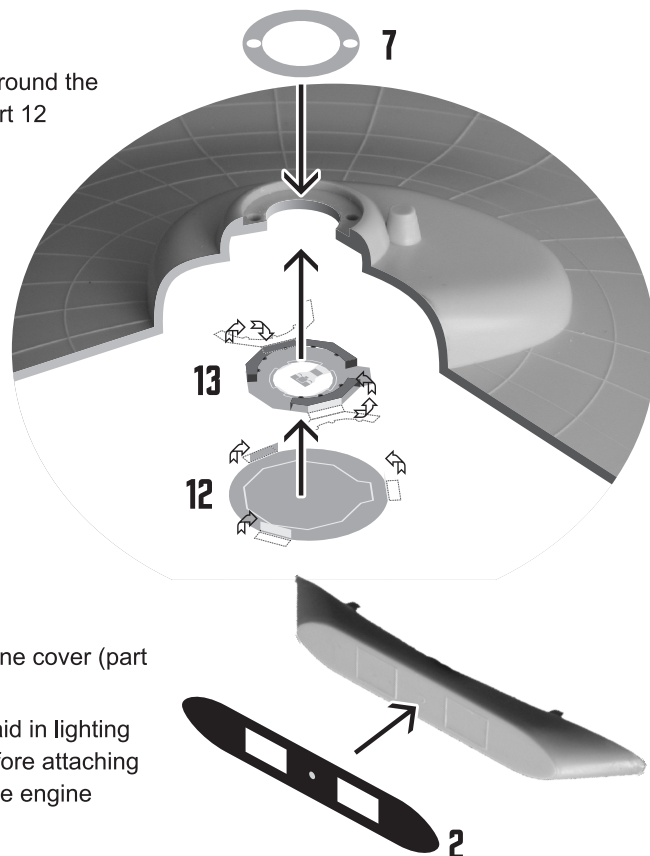

PART TWO: IMPULSE ENGINES

Remove the raised detail from the plastic part and attach the impulse engine cover (part 2) as shown. Notice the "up" arrow on the backside of the piece.

NOTES: You can remove plastic from the kit part behind the openings to aid in lighting if you wish to replicate the look of the remastered episodes - but do so before attaching the photoetched piece. This piece layout will work with either set of impulse engine decals included with the kit.

PART THREE: DEFLECTOR

Mount pieces 4, 5, 9, and 10 as shown. Note that 4 goes on the starboard side, and 5 on the port. For the highest accuracy, parts 4 and 5 should extend past edge of the model by the amount that the grooves are inset as shown.

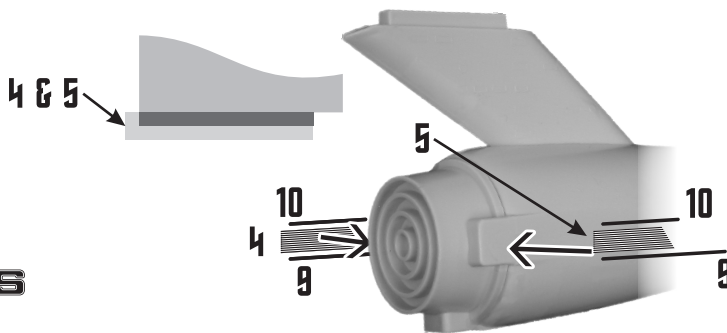

PART FOUR: WARP ENGINES

GRILLS

File / sand off the existing grills from warp engine pylons and replace with the pieces provided (parts 3).

Attach a piece of 0.02" (0.5mm) sheet plastic between the raised "rails" above and below the existing warp engine grills. The piece will be roughly 4.75" long and 0.187" wide (120mm x 4.8mm) - test fit this piece before assembly.

Glue the warp engine grills and spacer in place as shown on both warp engines.

BUSSARD COLLECTOR ROTORS

NOTES: The rotors (parts 8 and 11) are useful only if you are incorporating clear engine domes to replace the kit parts. Since there are several different types of domes available from many manufacturers, the image below shows a typical opaque dome.

TIP: If you want to make the rotors spin, you can mount a pin through the axle holes in the rotors and hubs. Motor mounting and design is up to the user.

TIP: Compatible with the Voodoo FX Nacelle Effect lighting kit. If you are lighting the domes and don't want shadows from the hubs, the spokes can be removed. We have included small, scribed lines as a cutting aid.

Before bending the rotors (parts 8) you will need to anneal them. We have left this portion of the instructions until the end so that you can remove all of the other pieces and leave parts 8 (and the primary hull triangles, parts 6) attached to the fret. If you are unsure how to anneal, see the article listed at the beginning of the instructions or an article on the web.

Bend the rotors as shown and glue to the hubs (parts 11). Note that the radius of the bend you use will depend upon the dome choice you are using. Then mount in the bussard domes.

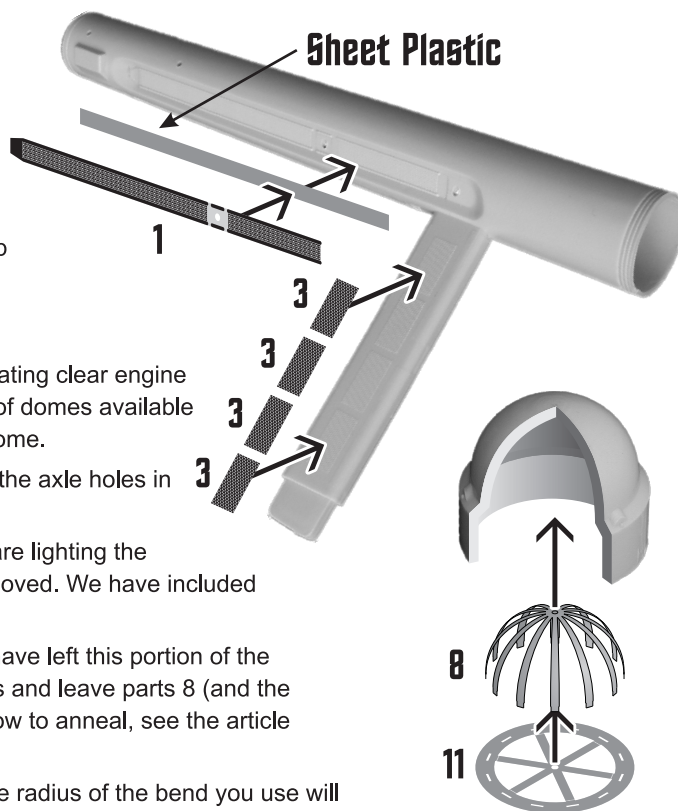

PART FIVE: PRIMARY HULL TRIANGLES

Attach pieces 6 as shown. Note that these pieces are designed to work with the latest version of the Enterprise decals from JT Graphics - earlier versions of these decals have skewed triangles that may not match. You may find that annealing the triangles makes them easier to fit into place.

Note that parts 14 can be added to the base of the triangles for added accuracy, but only if not using the JT Graphics decals. Alternatively, two pieces of 0.025" (0.6mm) half round plastic may be used.

ACKNOWLEDGMENTS:

Thanks to Steve "CultTVman" Iverson for the push to make this set ... and the idea of making a bridge. Thanks also to Jeffrey "JT Graphics" Wacławski and Randy "Voodoo FX" Neubert for advising me on the technical aspects of their products so that I could ensure compatibility.

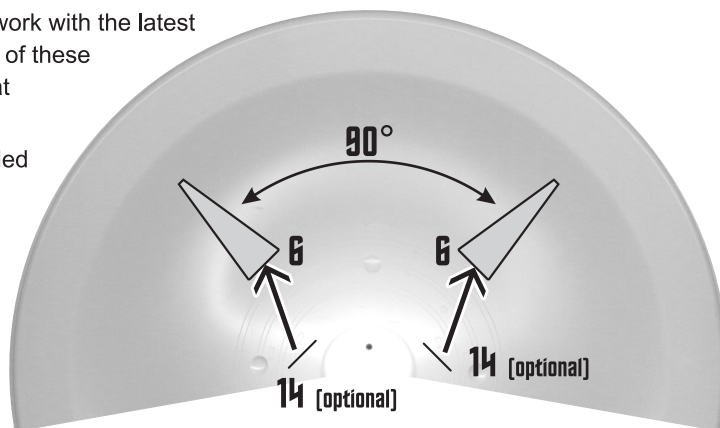

PGMS ParaGrafix
Modeling Systems

148 Rocklawn Avenue
Attleboro MA 02703 USA

(508) 431-9800
www.ParaGrafix.biz

Copyright © 2009 Paul H. Bodensiek dba ParaGrafix Modeling Systems. All Rights Reserved