



LEVEL 5

1 2 3 4 5



Antonov An-225 „Mrija“

Beiliegenden Sicherheitstext beachten / Please note the enclosed safety advice

- DE Beiliegenden Sicherheitstext beachten und nachschlagbereit halten.
- GB Please note the enclosed safety advice and keep safe for later reference.
- FR Respecter les consignes de sécurité ci-jointes et les conserver à portée de main.
- NL Houdt u aan de bijgaande veiligheidsinstructies en hou deze steeds bij de hand.
- IT Seguire le avvertenze di sicurezza allegate e tenerle a portata di mano.
- ES Observar y siempre tener a disposición este texto de seguridad adjunto.
- PT Ter em atenção o texto de segurança anexo e guardá-lo para consulta.
- DK Overhold vedlagte sikkerhedsanvisninger og hav dem liggende i nærheden.
- NO Ha alltid vedlagt sikkerhetstekst klar til bruk.
- SE Beakta bifogad säkerhetstext och håll den i beredskap.
- FI Huomioi ja säilytä oheiset varoitukset.
- RU Соблюдать технику безопасности, сохранить инструкцию для дальнейших обращений.
- PL Przestrzegać załączonego tekstu dotyczącego bezpieczeństwa i mieć go zawsze pod ręką.
- CZ Dodržujte tento příložený bezpečnostní text a mějte ho po ruce.
- HU A mellékelt biztonsági szöveget vegye figyelembe és tartsa fellapozásra készen.
- SK Rešpektujte priložený bezpečnostný text a uchovajte ho pre budúce použitie.
- RO Respectați textul de siguranță atașat și păstrați-l la îndemână.
- BG Спазвайте приложения текст за безопасност и го дръжте под ръка за справки.
- SJ Priloga varnostna navodila izvajajte in jih hranite na vsem dostopnem mestu.
- GR Λάβετε υπόψη σας το συννημένο κείμενο ασφαλείας και φυλάξτε το ώστε να ανατρέχετε σε αυτό όποτε χρειάζεται.
- TR Ektekiğüvenlik talimatlarını dikkate alıp, bakabileceğiniz bir şekilde muafaza ediniz.

© 2018 Revell GmbH, Henschelstr. 20-30, D-32257 Bünde.

REVELL IS THE REGISTERED TRADEMARK OF REVELL GMBH, GERMANY. www.revell.de

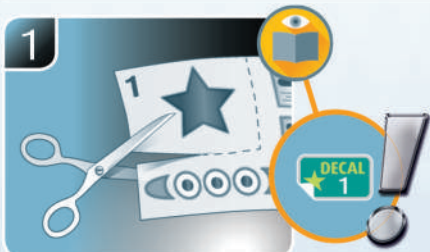
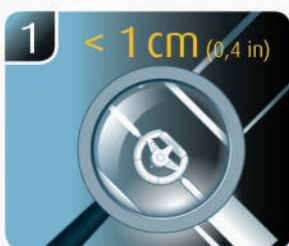
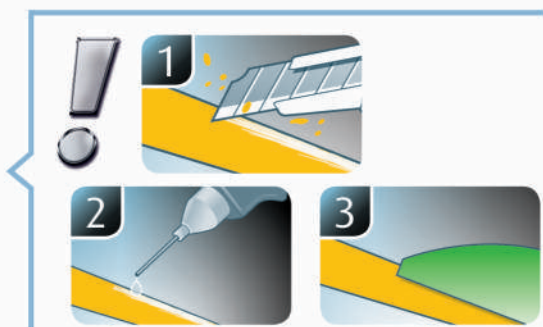
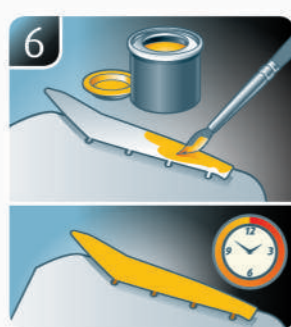
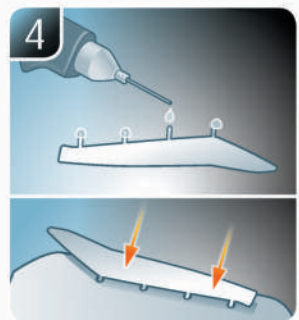
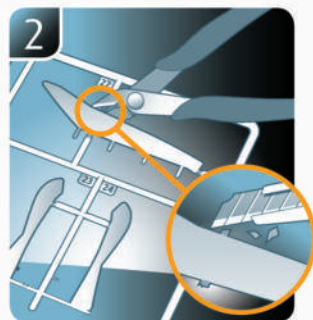
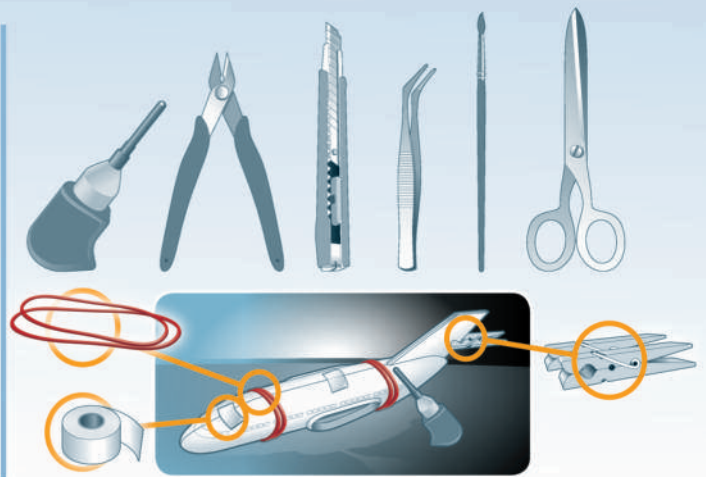

☞ Weitere Tipps und Tricks.
 ☞ Additional tips and tricks.
 ☞ Conseils et astuces supplémentaires.
 ☞ Andere tips en trucs.
 ☞ Ulteriori consigli e suggerimenti.
 ☞ Consejos y sugerencias adicionales.
 ☞ Mais dicas e truques.

☞ Flere tips og tricks.
 ☞ Flere tips og tricks.
 ☞ Ytterligare tips och tricks.
 ☞ Lisää vinkkejä ja niksejä.
 ☞ Другие советы и хитрости.
 ☞ Dalsze wskazówki i sugestie.
 ☞ Dalsí tipy a rady.
 ☞ További ötletek és fogások.
 ☞ Dalsie tipy a triky.
 ☞ Alte sfaturi și trucuri.

☞ Други полезни съвети и трикове.
 ☞ Nadaljnji nasveti in zvižaje.
 ☞ Πρόσθετες συμβουλές και κόλπα.
 ☞ Diğer öneriler ve ipuçları.

www.revell.de



- DE Kleben
- FR Glue
- FR Coller
- NL Lijmen
- IT Incollare
- ES Pegamento
- PT Colar
- HU Lim
- NO Lime
- SE Limma
- FI Liimaa
- RU Клеить
- PL Przykleić
- CZ Slepění
- HU Ragassza rá
- SK Lepiť
- NO Lipiti
- RO Zălenete
- SI Prilepiti
- GR ΚΑΛΗΣΤΕ
- TR Yapıştırma



- DE Nicht kleben
- FR Don't glue
- FR Ne pas coller
- NL Niet lijmen
- IT Non incollare
- ES No pegamento
- PT Não colar
- HU Lim ikke
- NO Ikke lime
- SE Limma inte
- FI Älä liimaa
- RU Не клеить
- PL Nie przyklejać
- CZ Nelepít
- HU Ne ragassza rá
- SK Nelepíť
- NO Nu lipiti
- RO Ne lepete
- SI Ne lepiti
- GR Μην κολλήσετε
- TR Yapıştırmayın



- DE Bemalen
- FR Paint
- FR Peindre
- NL Beschilderen
- IT Colorare
- ES Pintar
- PT Pintar
- HU Mal
- NO Male
- SE Måla
- FI Maalaa
- RU Раскрасить
- PL Pomalować
- CZ Pomalovat
- HU Fesse be
- SK Natriet
- NO Vopsiți
- RO Bоядисайте
- SI Pobarvajte
- GR Βάψτε
- TR Boyama



- DE Zusammenbau Reihenfolge.
- FR Sequence of assembly.
- FR Ordre d'assemblage.
- NL Volgorde van montage.
- IT Sequenza di assemblaggio.
- ES Secuencia de montaje.
- PT Sequência de montagem.
- HU Samlerækkefølge.
- NO Monteringsrekkefølge.
- SE Montering ordningsföljd.
- FI Kokoamisjärjestys.
- RU Последовательность сборки.
- PL Kolejność montażu.
- CZ Pořadí složení.
- HU Összerakási sorrend.
- SK Poradie zostavenia.
- RO Ordinea asamblării.
- GR Последовательност на сглобяване.
- SI Vrtni red sestavljanja.
- GR Σειρά τοποθέτησης.
- TR Parçaları birleştirme sırası.



- DE Anzahl der Arbeitsgänge.
- FR Number of working steps.
- FR Nombre d'étapes de travail.
- NL Het aantal bouwstappen.
- IT Numero di fasi di lavoro.
- ES Número de pasos de trabajo.
- PT Número de passos de trabalho.
- HU Antal arbeitsgange.
- NO Antall arbeidsstrinn.
- SE Antal operationer.
- FI Työvaiheiden määrä.
- RU Количество операций.
- PL Liczba cykli roboczych.
- CZ Počet pracovních kroků.
- HU A munkamenetek száma.
- SK Počet pracovných operácií.
- RO Numărul etapelor de lucru.
- GR Брой работни стъпки.
- SI Število delovnih postopkov.
- GR Αριθμός βημάτων εργασίας.
- TR Çalışma adımı sayısı.



- DE Wahlweise
- FR Optional
- FR Facultatif
- NL Naar keuze
- IT Facoltativamente
- ES Opcional
- PT Opcional
- HU Valgfri
- NO Valgfritt
- SE Valfri
- FI Valinnaisesti
- RU На выбор
- PL Opcjonalnie
- CZ Volitelně
- HU Választás szerint
- SK Alternativne
- NO Optional
- RO По избору
- SI Izbirno
- GR Προαιρετικά
- TR Opsiyonel



- DE Achtung
- FR Attention
- FR Attention
- NL Obgelet
- IT Attenzione
- ES Atención
- PT Atenção
- HU Obs!
- NO OBS
- SE OBS
- FI Huomio
- RU Внимание
- PL Uwaga
- CZ Pozor
- HU Figyelem!
- SK Pozor
- NO Atnenning
- SI Varnost
- GR Προσοχή
- TR Dikkat



- DE Bauteile trocknen lassen.
- FR Allow the parts to dry.
- FR Laisser sécher les pièces.
- NL Ouderdelen laten drogen.
- IT Lasciare asciugare i componenti.
- ES Dejar secar las piezas.
- PT Deixar as peças secar.
- HU Lad delene tøre.
- NO Tørk komponenter.
- SE Låt komponenterna torka.
- FI Anna rakenneosien kuivua.
- RU Дайте деталям высохнуть.
- PL Pozostawić elementy konstrukcji do wyschnięcia.
- CZ Nechte díly uschnout.
- HU Hagyja megszáradni az alkatrészeket.
- SK Konštrukčné diely nechajte vyschnúť.
- RO Lăsați componentele să se usuce.
- GR Οставьте сглобените части да изсъхнат.
- SI Osušite sestavne dele.
- GR Αφήστε τα μέρη να στεγνώσουν.
- TR Yarı parçalarını kurumaya bırakın.



- DE Abbildung zusammengesetzter Teile.
- FR Illustration of assembled parts.
- FR Figure représentant les pièces assemblées.
- NL Afbeelding van samengevoegde onderdelen.
- IT Foto delle parti assemblate.
- ES Figura de las piezas montadas.
- PT Ilustração das peças montadas.
- HU Illustration af samlede dele.
- NO Figur av sammensatte deler.
- SE Bild på sammansatta detaljer.
- FI Kootujen osien kuva.
- RU Изображение смонтированных деталей.
- PL Rysunek połączonych części.
- CZ Zobrazení spojených dílů.
- HU Összerakott alkatrészek ábrája.
- SK Obrázok dielov, ktoré sa majú zmontovať.
- RO Figura reprezentând piesele asamblate.
- GR Изображение на сглобените части.
- SI Slika sestavljenih delov.
- GR Απεικόνιση των τοποθετημένων μερών.
- TR Birleştirilmiş parçalar resmi.



- DE Loch bohren.
- FR Make a hole.
- FR Faire un trou.
- NL Maak een gat.
- IT Praticare un foro.
- ES Hacer un agujero.
- PT Fazer um furo.
- HU Lav et hul.
- NO Bor et hull.
- SE Borra hål.
- FI Poraa reikä.
- RU Просверлить отверстие.
- PL Wywiercić otwór.
- CZ Vytvářet otvor.
- HU Fúrjon lyukat.
- SK Vytvárajte otvor.
- NO Faceji o gaurá.
- RO Пробиайте дупка.
- SI Izvrtajte izvrtino.
- GR Ανοίξτε τρύπη.
- TR Delik açın.



- DE Gleichen Vorgang auf der gegenüberliegenden Seite wiederholen.
- FR Repeat same procedure on opposite side.
- FR Opérer de la même façon sur l'autre face.
- NL Dezelfde handeling herhalen aan de tegenoverliggende kant.
- IT Ripetere il procedimento dall'altra parte.
- ES Repetir el mismo procedimiento en el lado contrario.
- PT Repetir alguns procedimentos no lado oposto.
- HU Gentag procedurén på den modstående side.
- NO Gjenta samme forlop på motliggende side.
- SE Upprepa samma process på motsatta sidan.
- FI Toista menettely vastakkaisella puolella.
- RU Повторить такие же действия на противоположной стороне.
- PL Powtórzć te same czynności po przeciwnej stronie.
- CZ Stejný postup opakujte na protilehlé straně.
- HU Ismételj meg a műveletet az ellentétes oldalon.
- SK Rovnaký postup zopakujte na protilehlej strane.
- NO Repetati același procedeu pe latura opusă.
- RO Повторете същите стъпки на срещуположната страна.
- SI Enak postopek ponovite na nasprotni strani.
- GR Επανάλαβετε την ίδια διαδικασία στην αντίθετη πλευρά.
- TR Aynı işlem adımlarını diğer tarafta da uygulayın.



- DE Bauanleitung sorgfältig lesen.
- FR Read the assembly instructions carefully.
- FR Lisez attentivement les instructions de montage.
- NL Bouwinstructies zorgvuldig doorlezen.
- IT Leggere attentamente le istruzioni per il montaggio.
- ES Lea cuidadosamente las instrucciones de montaje.
- PT Ler atentamente as instruções de montagem.
- HU Lás byggevejledningen omhyggeligt.
- NO Les byggeanvisningen nøye.
- SE Monteringsinstruktionerna skall läsas noggrant.
- FI Lue kokoamisohje huolellisesti.
- RU Внимательно прочитайте инструкцию по сборке.
- PL Dokładnie przeczytać instrukcję montażu.
- CZ Přečtěte si pečlivě návod k obsluze.
- HU Figyelemesen olvassa el a szerelési útmutatót.
- SK Návod na montáž starostlivo prečítajte.
- NO Citij si atentione instructiunile de montare.
- RO Прочетете внимателно урътъването за монтаж.
- SI Skrbno preberite navodila za sestavo.
- GR Διαβάστε προσεκτικά τις οδηγίες κατασκευής.
- TR Yarı kılavuzunu dikkatle okuyun.



- DE Klarsichtteile
- FR Clear parts
- FR Pièces transparentes
- NL Transparente onderdelen
- IT Parti trasparenti
- ES Piezas transparentes
- PT Peças transparentes
- HU Klare dele
- NO Klare deler
- SE Genomsiktliga detaljer
- FI Läpinäkyvät osat
- RU Прозрачные детали
- PL Przejrzyste części
- CZ Průhledné díly
- HU Átlátszó alkatrészek
- SK Číre diely
- NO Piese transparente
- RO Прозрачни части
- SI Prozorni deli
- GR Διαφανή μέρη
- TR Şeffaf parçalar



- DE Zur besseren Ausbalancierung mit einem Gewicht beschweren.
- FR Add weight for improved stability.
- FR Pour une mise en place correcte alourdir.
- NL Voor evenwicht gewicht aanbrengen.
- IT Aggiungere un peso per migliorare la stabilità.
- ES Añadir peso para una mayor estabilidad.
- PT Para melhor estabilidade colocar um peso.
- HU Tilføj vægt for at forbedre stabiliteten.
- NO Legg til vekt for en bedre stabilitet.
- SE Belastas med en vikt för bättre balansering.
- FI Painota painolla parempaa tasapainottamista varten.
- RU Для лучшей балансировки утяжелить грузом.
- PL Aby zapewnić równowagę, obciążać ciężarkiem.
- CZ Pro lepší vyvážení zatěžte závažím.
- HU A jobb kiegyensúlyozás érdekében használjon súlynehezéket.
- SK Pre lepšie vyváženie zatažte závažím.
- NO Aplicati o greutate pentru o mai bună stabilitate.
- RO За по-добър баланс поставете тежест.
- SI Za boljše izravnavo obtežite z utežjo.
- GR Προσθέστε αντίβαρο για καλύτερη σταθερότητα.
- TR Daha iyi bir dengeleme için ağırlık yerleştirin.



- DE Mit Klebeband fixieren.
- FR Attach with adhesive tape.
- FR Fixer à l'aide de ruban adhésif.
- NL Met plakband vastzetten.
- IT Fissare con nastro adesivo.
- ES Fijar con cinta adhesiva.
- PT Fixar com fita adesiva.
- HU Fastgør med tape.
- NO Fest med tape.
- SE Fixera med tejp.
- FI Kiinnittää liimanauhalla.
- RU Зафиксировать липкой лентой.
- PL Przytrocować za pomocą taśmy samoprzylepnej.
- CZ Připevňete lepicí páskou.
- HU Rögzítse ragasztószalaggal.
- SK Fixujte lepiacou páskou.
- NO Fixati cu bandă adezivă.
- RO Фиксирайте с тиксо.
- SI Pritrđiti z lepilnim trakom.
- GR Στερεώστε κολλητική ταινία.
- TR Yapıştırma bandı ile sabitleyin.



- DE Mit einem Messer abtrennen.
- EN Detach with knife.
- FR Détacher au couteau.
- NL Met een mesje afsnijden.
- IT Separare con un coltello.
- ES Separar con cuchillo.
- PT Separar com uma faca.
- NO Skær af med en kniv.
- NO Separer med kniv.
- SE Skall skiljas av med en kniv.
- FI Erota veitsellä.
- RU Отделить ножом.
- PL Oddzielić za pomocą noża.
- CZ Oddělte nožem.
- HU Válassza le késsel.
- SK Oddelte nožom.
- NO Desprindeti cu un cuțit.
- NO Откъснете с нож.
- SI Odrežite z ustreznim rezilom.
- GR Αφαιρέστε με ένα μαχαίρι.
- TR Bir bıçak ile kesin.



- DE Abziehbild in Wasser einweichen und anbringen.
- EN Soak and apply decals.
- FR Mouiller et appliquer les décalcomanies.
- NL Transfer in water even laten weken en aanbrengen.
- IT Immergere la decalcomania nell'acqua e applicarla.
- ES Mojar y aplicar calcomanías.
- PT Amolecer o decalque em água e aplicar.
- NO Gör overføringsbilledet vådt og sæt det på.
- NO Myk opp avtrekkingsbildet i vann og sett på.
- SE Blötlägg dekalen i vatten och sätt på den.
- FI Pehmitä siirtokuva vedessä ja siirrä paikalleen.
- RU Опустите переводную картинку в воду и нанесите её.
- PL Namoczyć kalkomanie w wodzie i przykleić.
- CZ Nechte obtisk odmočit ve vodě a přilepte.
- HU Merítse vízbe és helyezze fel a matricát.
- SK Obtlačkový obrázok namočte do vody a priložte na plochu.
- NO Innuiajtí abtíbuldul in apă și aplicați-l.
- NO Потопете ваденката във вода и я поставяте.
- SI Prelepnicno namakajte v vodi. In namestite.
- GR Μουσκεύετε σε νερό και τοποθετείτε τις χαλκομανίες.
- TR Çikartmayı suda yumuşatın ve takın.



*

- DE Zur Anbringung der Klarteile empfohlen.
- EN Recommended to fix clear parts.
- FR Recommandé pour fixer les pièces transparentes.
- NL Aanbevolen voor het aanbrengen van transparante delen.
- IT Raccomandato per l'applicazione delle parti trasparenti.
- ES Recomendado para fijar las piezas transparentes.
- PT Recomendado para a aplicação das peças transparentes.
- NO Anbefales til anbringelse af de klare dele.
- NO Anbefales til å feste klare deler.
- SE Rekommenderad för montering av de genomskinliga detaljerna.
- FI Suositellaan läpinäkyvien osien siirtämiseen.
- RU Рекомендуется для крепления прозрачных деталей.
- PL Zalecane do przyklejenia przezroczystych części.
- CZ Doporučujeme k umístění průhledných dílů.
- HU Az átlátszó darabok felhelyezéséhez ajánlható.
- SK Odporúčame sa pre umiestnenie čírych dielov.
- NO Recomandat pentru aplicarea pieselor transparente.
- NO Препоръчва се за поставяне на прозрачни части.
- SI Pri nameščanju prozornih delov priporočamo.
- GR Συνιστάται για την τοποθέτηση των διαφανών μερών.
- TR Şeffaf parçaların takılması için önerilir.



*

- DE Zur Anbringung der Abziehbilder empfohlen.
- EN Recommended for affixing the decals.
- FR Recommandé pour l'application des décalcomanies.
- NL Aanbevolen voor het aanbrengen van de transfers.
- IT Raccomandato per l'applicazione delle decalcomanie.
- ES Recomendado para fijar bien las calcomanías.
- PT Recomendado para a fixação dos autocolantes.
- NO Anbefales til anbringelse af overføringsbillederne.
- NO Anbefales til å feste avtrekksbilder.
- SE Rekommenderad för montering av klisterdekalerna.
- FI Suositellaan siirtokuvien siirtämiseen.
- RU Рекомендуется для нанесения переводных картинок.
- PL Zalecane do przyklejenia kalkomanii.
- CZ Doporučujeme k umístění obtiskovacích obrázků.
- HU A matrica felhelyezéséhez ajánlható.
- SK Odporúčame sa pre umiestnenie obtlačkového obrázku.
- NO Recomandat pentru aplicarea abtíbulurilor.
- NO Препоръчва се за поставяне на ваденки.
- SI Pri nameščanju nalepnic priporočamo.
- GR Συνιστάται για την τοποθέτηση των χαλκομανιών.
- TR Çikartmaların takılması için önerilir.

*

- DE Nicht enthalten
- EN Not included
- FR Non fourni
- NL Behoort niet tot de levering
- IT Non incluso
- ES No incluido
- PT Não incluído
- NO Medfølger ikke
- NO Ikke inkludert
- FI Ingår ej
- FI Ei sisällä
- RU Не содержится
- PL Nie wchodzi w zakres dostawy
- CZ Není obsaženo
- HU Nem tartalmazza
- SK Neobsahuje
- NO Nu este inclus
- NO Не се включва в комплекта
- SI Ni priloženo
- GR Δεν περιλαμβάνεται
- TR İçermiyor

Benötigte Farben / Required colours

FR Peintures nécessaires
NL Benodigde kleuren
IT Colori necessari
ES Colores necesarios
PT Cores necessárias
DK Nødvendige farver
NO Nødvendige farger
SE Erforderliga färger
FI Tarvittavat värit
RU Необходимые краски
PL Potrzebne kolory
CZ Potřebné barvy
HU Szükséges színek
SK Požadované farby
RO Culori necesare
BG Необходими цветове
SI Potrebne barve
GR Απαιτούμενα χρώματα
TR Gerekl renkler

04

A

DE Weiß glänzend
GB White gloss
FR Blanc brillant
NL Wit glanzend
IT Bianco lucido
ES Blanco brillante
PT Branco brilhante
DK Hvid blank
NO Hvit glansende
SE Vit blank
FI Valkoinen kiiltävä
RU Белый глянцевый
PL Biały błyszczący
CZ Bílá lesklý
HU Fehér, fényes
SK Biela lesklý
RO Alb strălucitor
BG Бяло гланцово
SI Bela sijoca
GR Ασπρο γυαλιστερό
TR Beyaz parlak

90

B

DE Silber metallic
GB Silver metallic
FR Argent métallique
NL Zilver metallic
IT Argento metallico
ES Plata metálico
PT Prata metálico
DK Sølv metallisk
NO Sølv metallic
SE Silver metallic
FI Hopea metallinen
RU Серебрянный металл
PL Srebrny metaliczny
CZ Stříbrná metalizový
HU Ezüstmetál
SK Strieborná metaliza
RO Argintiu metalic
BG Сребро металик
SI Srebrna kovinska
GR Ασημί μεταλλικό
TR Gümüş rengi metalik

90%

76

D

15

10%

DE Hellgrau matt
GB Light grey matt
FR Gris clair mat
NL Lichtgrijs mat
IT Grigio chiaro opaco
ES Gris claro mate
PT Cinza claro mate
DK Lysegrå mat
NO Lysegrå matt
SE Ljusgrå matt
FI Vaaleanharmaa matta
RU Светло-серый матовый
PL Jasnoszary matowy
CZ Světlá šedivá matný
HU Világosszürke, fénytelen
SK Svetlo sivá matný
RO Gri-deschis mat
BG Светлосиво матово
SI Svetlo-siva mat
GR Γκρι ανοιχτό ματ
TR Açık gri mat

+

DE Gelb matt
GB Yellow matt
FR Jaune mat
NL Geel mat
IT Giallo opaco
ES Amarillo mate
PT Amarelo mate
DK Gul mat
NO Gul matt
SE Gul matt
FI Keltainen matta
RU Желтый матовый
PL Żółty matowy
CZ Žlutá matný
HU Sárga, fénytelen
SK Žltá matný
RO Galben mat
BG Жълто матово
SI Rumena mat
GR Κίτρινο ματ
TR Sarı mat

91

E

DE Eisen metallic
GB Iron metallic
FR Fer métallique
NL IJzer metallic
IT Ferro metallico
ES Acero metálico
PT Aço metálico
DK Stål metallisk
NO Jern metallic
SE Stål metallic
FI Teräs metallinen
RU Сталь металл
PL Grafit metaliczny
CZ Ocelová metalizový
HU Acélmetál
SK Ocelová metaliza
RO Fier metalic
BG Желязо металик
SI Železna kovinska
GR Χρώμα σιδήρου μεταλλικό
TR Metalik metalik

731

F

DE Rot klar
GB Red clear
FR Rouge clair
NL Rood helder
IT Rosso chiaro
ES Rojo claro
PT Vermelho transparente
DK Rödbrun klar
NO Rod klar
SE Rödbrun klar
FI Punainen kirkas
RU Красный прозрачный
PL Czerwony przezroczysty
CZ Červená bezbarvý
HU Piros, világos
SK Červená číry
RO Roșu curat
BG Червено бистро
SI Rdeča čista
GR Κόκκινο διάφανο
TR Kırmızı canlı

90%

91

G

84

10%

DE Eisen metallic
GB Iron metallic
FR Fer métallique
NL IJzer metallic
IT Ferro metallico
ES Acero metálico
PT Aço metálico
DK Stål metallisk
NO Jern metallic
SE Stål metallic
FI Teräs metallinen
RU Сталь металл
PL Grafit metaliczny
CZ Ocelová metalizový
HU Acélmetál
SK Ocelová metaliza
RO Fier metalic
BG Желязо металик
SI Železna kovinska
GR Χρώμα σιδήρου μεταλλικό
TR Metalik metalik

+

DE Lederbraun matt
GB Leather brown matt
FR Brun cuir mat
NL Lederbruin mat
IT Marrone pelle opaco
ES Marrón cuero mate
PT Castanho couro mate
DK Læderbrun mat
NO Læderbrun matt
SE Läderbrun matt
FI Nahanuskea matta
RU Коричневая кожа матовый
PL Skórzanoobrazowy matowy
CZ Kožená hnědá matný
HU Bőrszínű, fénytelen
SK Kožená hnedá matný
RO Maro pielos mat
BG Кафява кожа матово
SI Ušnjeno-rjava mat
GR Καφέ σκούρο ματ
TR Deri kahvesi mat

57

H

DE Grau matt
GB Grey matt
FR Gris mat
NL Grijs mat
IT Grigio opaco
ES Gris mate
PT Cinzento mate
DK Grå mat
NO Grå matt
SE Grå matt
FI Harmaa matta
RU Серый матовый
PL Szary matowy
CZ Šedá matný
HU Szürke, fénytelen
SK Sivá matný
RO Gri mat
BG Сиво матово
SI Siva mat
GR Γκρι ματ
TR Gri mat

360

I

DE Farngrün seidenmatt
GB Fern green silk matt
FR Vert fougère satiné mat
NL Varengroen zijdemat
IT Verde felce opaco satinato
ES Verde mate sedoso
PT Verde mate sedoso
DK Grøngrå silkematt
NO Bregnegroen silkematt
SE Ormbunksgrön sidenmatt
FI Vihreä silkkimatta
RU Зелёный папортник шелковисто-матовый
PL Zielony w odcieniu paproci jedwabście matowy
CZ Zelená jemně matný
HU Harasztzöld, fakóselymes
SK Zelená hodvábné matný
RO Verde-ferigă satinat
BG Папратовозелено коприненоматово
SI Praprotno-zelena svilenom-at
GR Πράσινο σατινέ
TR Yeşil ipeksi mat

09

J

DE Anthrazit matt
GB Anthracite matt
FR Anthracite mat
NL Antraciet mat
IT Antracite opaco
ES Antracita mate
PT Antracite mate
DK Antracitgrå mat
NO Antrasitt matt
SE Antracitgrå matt
FI Antrasiilinharmaa matta
RU Антрацит матовый
PL Antracyt matowy
CZ Antracitová šedá matný
HU Antracit, fénytelen
SK Čierna uhľová matný
RO Antracit mat
BG Антрацит матово
SI Antracit mat
GR Γκρι ανθράκι ματ
TR Antrazit mat

47

K

DE Mausgrau matt
GB Mouse grey matt
FR Gris souris mat
NL Muisgrijs mat
IT Grigio topo opaco
ES Gris claro mate
PT Cinzento claro mate
DK Musegrå mat
NO Musegrå matt
SE Musgrå matt
FI Hiirenharmaa matta
RU Мышино-серый матовый
PL Szary mysz matowy
CZ Mysí šedá matný
HU Egérszürke, fénytelen
SK Mysácia sivá matný
RO Gri-șoarece mat
BG Мишосиво матово
SI Mišje-siva mat
GR Γκρι ποντίκι ματ
TR Kirli gri mat

99

L

DE Aluminium metallic
GB Aluminium metallic
FR Aluminium métallique
NL Aluminium metallic
IT Alluminio metallico
ES Aluminio metálico
PT Alumínio metálico
DK Aluminium metallisk
NO Aluminium metallic
SE Aluminium metallic
FI Alumiini metallinen
RU Алюминий металл
PL Aluminium metaliczny
CZ Hliníková metalizový
HU Alumínium metál
SK Hliníková metaliza
RO Aluminiu metalic
BG Алюминий металик
SI Aluminijasta kovinska
GR Αλουμίνιο μεταλλικό
TR Alüminyum grisi metalik

30

O

DE Orange glänzend
 GB Orange gloss
 FR Orange brillant
 NL Oranje glanzend
 IT Arancio lucido
 ES Naranja brillante
 PT Laranja brilhante
 DK Orange blank
 NO Oransje glansende
 SE Orange blank
 FI Oranssi kiiltävä
 RU Оранжевый гляцевый
 PL Pomarańczowy błyszczący
 CZ Oranžová lesklý
 HU Narancs, fényes
 SK Oranžová lesklý
 RO Oranj strălucitor
 BG Оранжево гланцово
 SI Oranžna sijoča
 GR Πορτοκαλί γυαλιστερό
 TR Turuncu parlak

10%

51

P

04

90%

DE Ultramarinblau glänzend
 GB Ultramarine blue gloss
 FR Bleu outremer brillant
 NL Ultramarineblauw glanzend
 IT Blu oltremare lucido
 ES Azul marino brillante
 PT Azul marinho brilhante
 DK Ultra marineblå blank
 NO Ultra marineblå glansende
 SE Ultramarinblå blank
 FI Ultramariini kiiltävä
 RU Ультрамарин гляцевый
 PL Ultramaryna błyszcząca
 CZ Ultramarinová modř lesklý
 HU Ultramarin kék, fényes
 SK Ultramarin modrá lesklý
 RO Albastru ultramarin strălucitor
 BG Ултрамарин гланцово
 SI Ultramarinska-modra sijoča
 GR Μπλε βαθύ γυαλιστερό
 TR Lacivert parlak

+

DE Weiß glänzend
 GB White gloss
 FR Blanc brillant
 NL Wit glanzend
 IT Bianco lucido
 ES Blanco brillante
 PT Branco brilhante
 DK Hvid blank
 NO Hvit glansende
 SE Vit blank
 FI Valkoinen kiiltävä
 RU Белый гляцевый
 PL Biały błyszcząca
 CZ Bílá lesklý
 HU Fehér, fényes
 SK Biela lesklý
 RO Alb strălucitor
 BG Бяло гланцово
 SI Bela sijoča
 GR Ασπρο γυαλιστερό
 TR Beyaz parlak

76

Q

DE Hellgrau matt
 GB Light grey matt
 FR Gris clair mat
 NL Lichtgrijs mat
 IT Grigio chiaro opaco
 ES Gris claro mate
 PT Cinza claro mate
 DK Lysegrå mat
 NO Lysegrå matt
 SE Ljusgrå matt
 FI Vaaleanharmaa matta
 RU Светло-серый матовый
 PL Jasnoszary matowy
 CZ Světlá šedivá matný
 HU Világosszürke, fénytelen
 SK Svetlo sivá matný
 RO Gri-deschis mat
 BG Светлосиво матово
 SI Svetlo-siva mat
 GR Γκρι ανοιχτό ματ
 TR Açık gri mat

752

R

DE Blau klar
 GB Blue clear
 FR Bleu clair
 NL Blauw helder
 IT Blu chiaro
 ES Azul claro
 PT Azul transparente
 DK Blå klar
 NO Blå klar
 SE Blå klar
 FI Sininen kirkas
 RU Синий прозрачный
 PL Niebieski przezroczysty
 CZ Modrá bezbarvý
 HU Kék, világos
 SK Modrá čirý
 RO Albastru curat
 BG Синьо бистро
 SI Modra čista
 GR Μπλε διάφανο
 TR Mavi canlı

330

S

DE Feuerrot seidenmatt
 GB Fiery red silk matt
 FR Rouge feu satiné mat
 NL Vuurrood zijdemat
 IT Rosso fuoco opaco satinato
 ES Rojo fuego mate satinado
 PT Vermelho fogo mate sedoso
 DK Ildrød silkematt
 NO Ildrød silkematt
 SE Eldröd sidenmatt
 FI Tulenpunainen silkkimatta
 RU Огненно-красный шелковисто-матовый
 PL Ognistoczerwony jedwabście matowy
 CZ Ohnivě červená jemně matný
 HU Tűzpiros, fakóselymes
 SK Ohnivá červená hodvábne matný
 RO Roșu aprins satinat
 BG Огненочервено коприненоматово
 SI Ognjeno-rdeča svilenomat
 GR Κόκκινο φωτιάς σατινέ
 TR Alev kırmızısı ipeksi mat

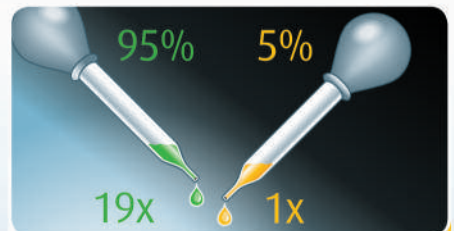

DE Beispiel: mischen
 GB Example: mixing
 FR Exemple: mélanger
 NL Voorbeeld: mengen
 IT Esempio: mescolare
 ES Ejemplo: mezclar
 PT Exemplo: misturar
 DK Eksempel: blanding
 NO Eksempel: blanding
 SE Exempel: blanda
 FI Esimerkki: sekoittaminen
 RU Пример: смешивание
 PL Przykład: mieszanie
 CZ Příklad: míchání
 HU Példa: keverés
 SK Příklad: miešanie
 RO Exemplu: amestecare
 BG Пример: смесване
 SI Primer: mešanje
 GR Παράδειγμα: ανάμειξη
 TR Örnek: karıştırma

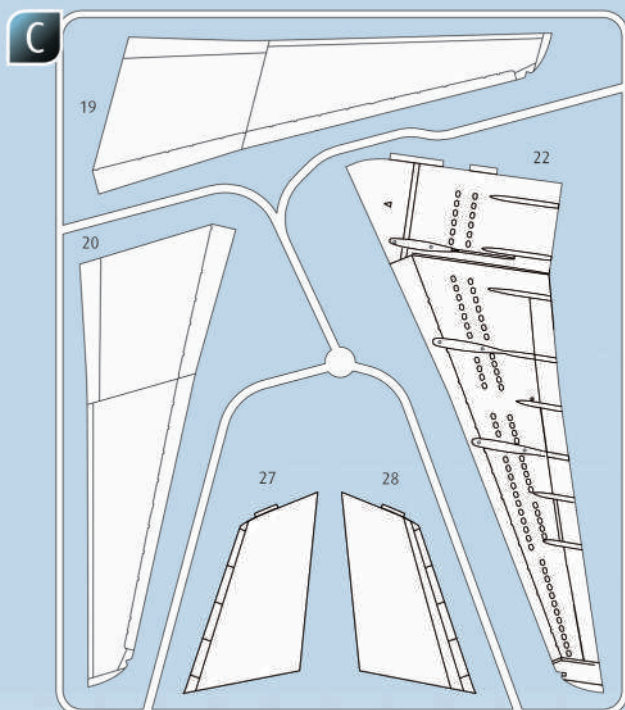
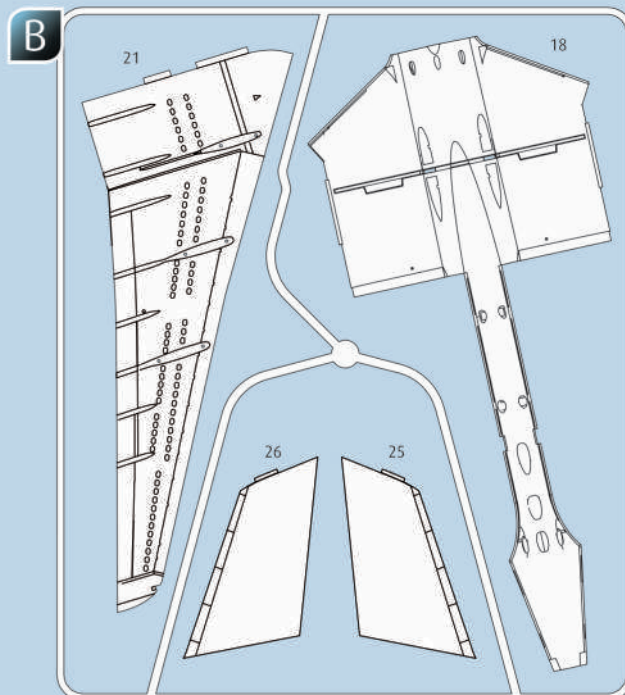
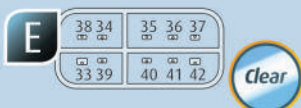
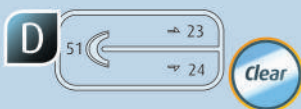
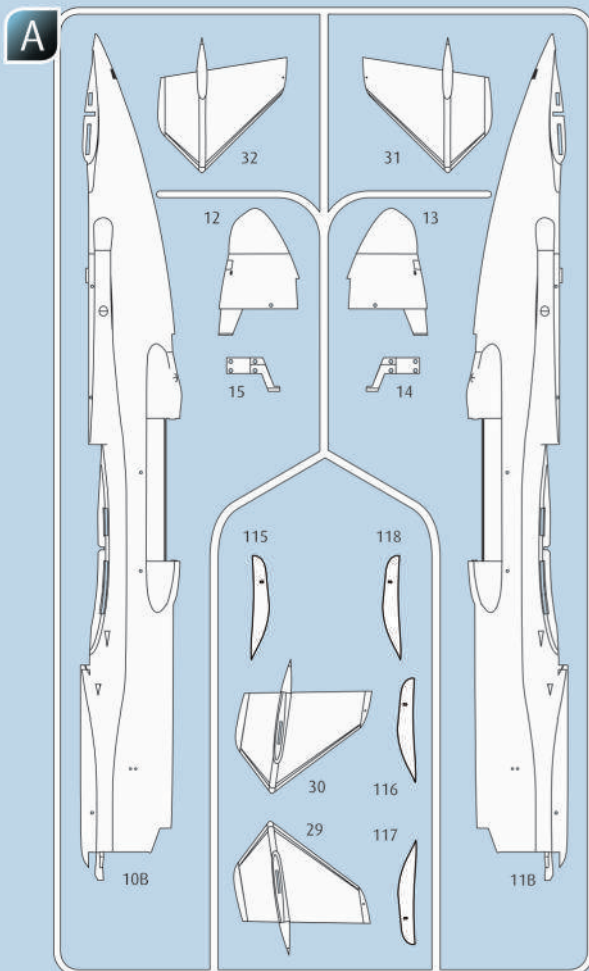

Ersatzteile benötigt?

Kein Problem. Einfach den Revell-Service mit Angabe von Artikel- und Teilenummer kontaktieren. Entweder unter service@revell.de oder Revell GmbH, Abteilung X, Henschelstr. 20-30, 32257 Bünde.*

*Wir bitten um Verständnis, dass eine Gewährleistung nur bei aktuellen Artikeln, die im Zeitraum der letzten 24 Monate erworben wurden, übernommen werden kann. Mit der Ersatzteil-Bestellung können Kosten z.B. für Verpackung und Versand entstehen. Ob diese Kosten anfallen wird im Vorfeld schriftlich durch unseren Service mitgeteilt. Das Angebot kann dann angenommen oder abgelehnt werden. Unfrei eingesandte Ersatzteil-Bestellungen werden von uns nicht angenommen! Dieser Direktservice gilt für die Länder Deutschland, Benelux, Österreich, Frankreich, Großbritannien. Ersatzteil-Bestellungen aus den übrigen Ländern werden über die jeweiligen Distributeure abgewickelt. Bitte kontaktieren Sie Ihren Händler.

Besoin de pièces de rechange ?

Il vous suffit de contacter le service Revell et d'indiquer la référence de l'article et de la pièce. Soit en écrivant par mail à france@revell.de (uniquement pour la France) ou par courrier à Revell GmbH, Département X, Henschelstr. 20-30, D-32257 Bünde.*

*La garantie s'applique pour les articles présents au catalogue et achetés au cours des 24 derniers mois. Merci de votre compréhension. La commande de pièces de rechange peut donner lieu à des frais supplémentaires, par ex. pour l'emballage et le port. Notre service client vous en informera au préalable par écrit. Vous pourrez accepter ou refuser le devis. Nous n'acceptons pas les commandes de pièces de rechange envoyées sans affranchissement ! Ce service direct est valable pour les pays suivants : Allemagne, Benelux, Autriche, France, Grande-Bretagne. Les commandes de pièces en provenance d'autres pays sont traitées par les distributeurs correspondants. Veuillez contacter votre revendeur.

Need spare parts?

No problem. Contact Revell Service with the item number and part numbers you need: service@revell.de or Revell GmbH, Unit 10, Old Airfield Industrial Estate, Cheddington Lane, Tring, Herts, HP23 4QR, Great Britain.*

*We request your understanding that a warranty can only be accepted for current articles which have been purchased in the last 24 months. Orders for spare parts may also be subject to costs for packaging and shipping. You will be notified in advance by our Service department if such costs are incurred. The offer can then be accepted or rejected. We will not be able to process any postal requests unless correct postage has been applied to mailing! This direct service applies to the countries: Germany, Benelux, Austria, France, and the United Kingdom. Spare part orders from other countries are processed by the local distributors. Please contact your dealer.

Hebt u reserveonderdelen nodig?

Geen probleem! Neem eenvoudig contact op met de klantenservice van Revell en geef ons het artikel- en onderdeelnummer door. U kunt ons bereiken op service@revell.de of per post: Revell GmbH, Afdeling X, Henschelstr. 20-30, 32257 Bünde.*

*Wij vragen uw begrip voor de omstandigheid, dat er alleen garantie kan worden geboden voor actuele artikelen, die in de afgelopen 24 maanden zijn gekocht. Met het bestellen van reserveonderdelen kunnen kosten gemoeid zijn, bijv. voor verpakking en verzending. U wordt vooraf schriftelijk door onze klantenservice op de hoogte gesteld als er kosten zouden ontstaan. Het aanbod kan dan worden aangenomen of afgewezen. Wij nemen geen ongefrankeerde bestellingen van reserveonderdelen aan! Deze rechtstreekse service wordt verleend in de landen Duitsland, de Benelux, Oostenrijk, Frankrijk en Groot-Brittannië. Bestellingen van reserveonderdelen in de overige landen worden afgewikkeld via de betreffende distributeurs. Neem hiervoor contact op met uw verkoper.

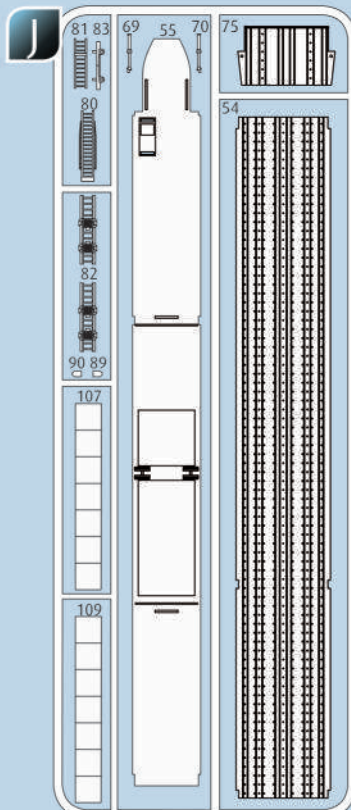
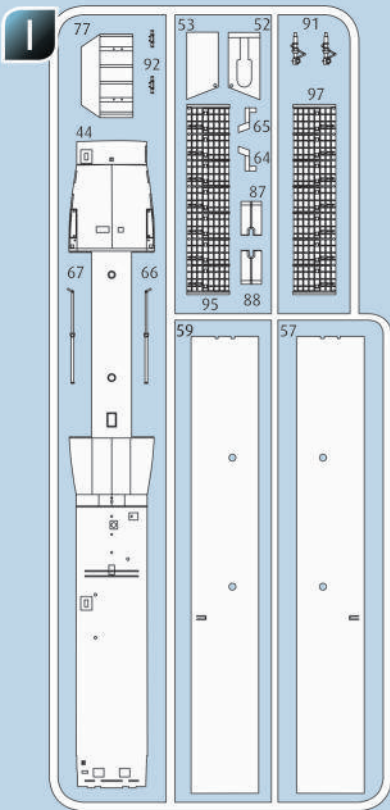
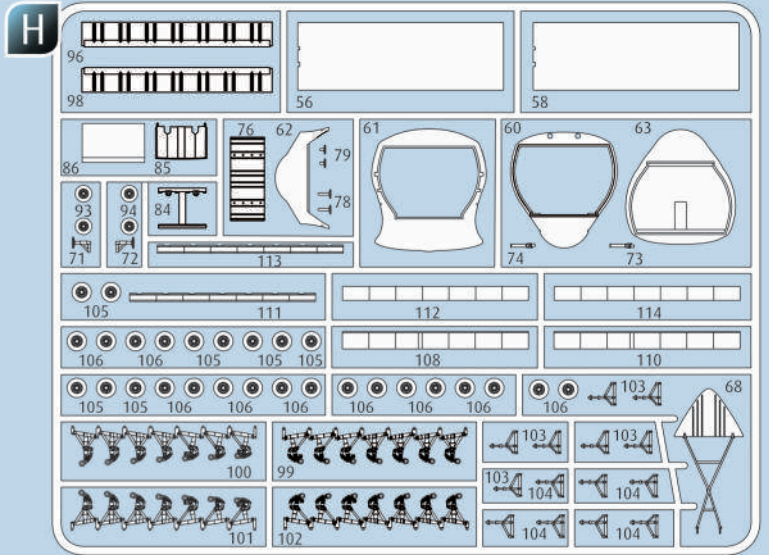
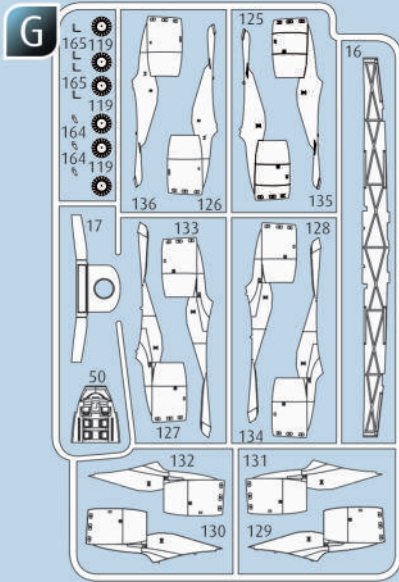
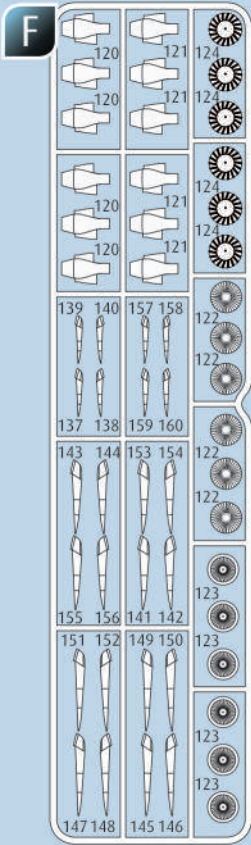

Version 1

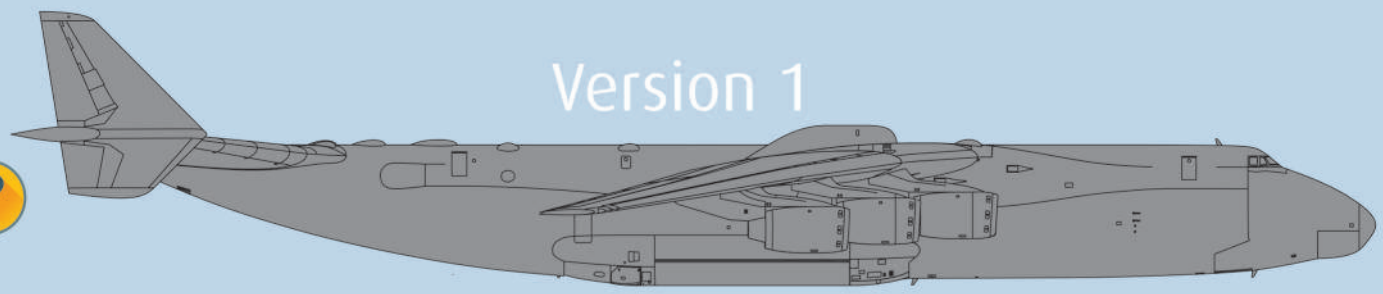

Version 2





Version 3



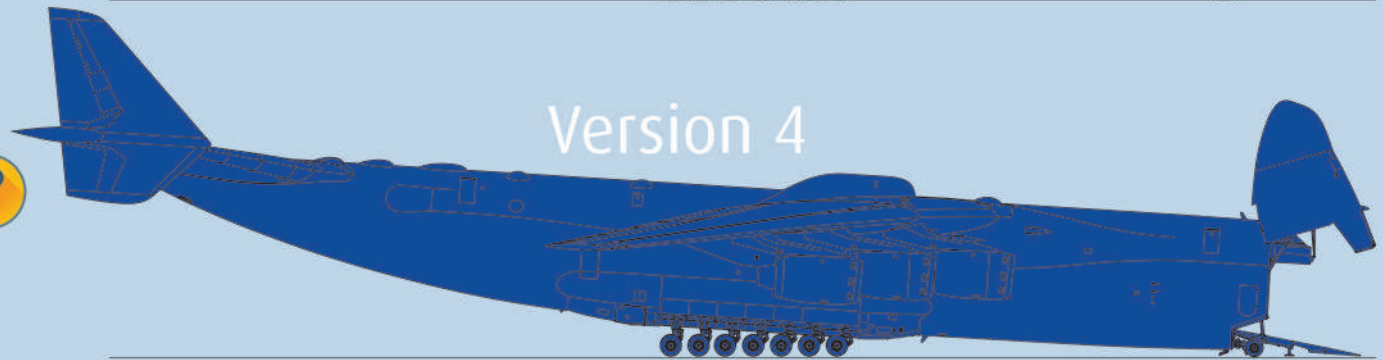

Version 4

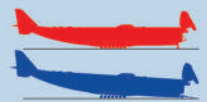

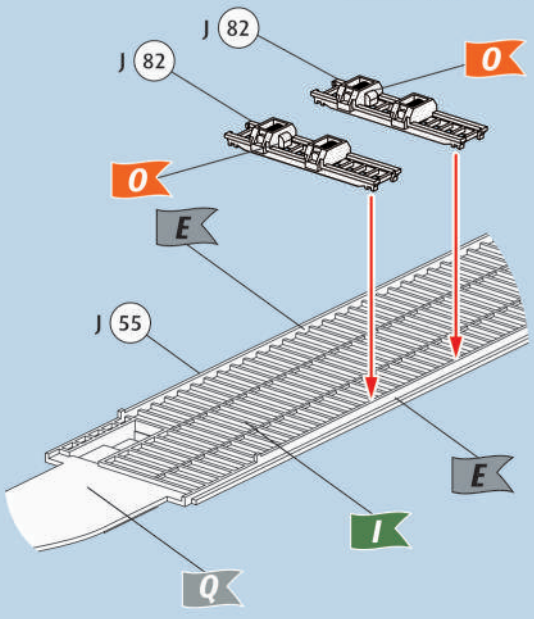
1    



J 82
J 82
E
E
I
Q
J 55

2   

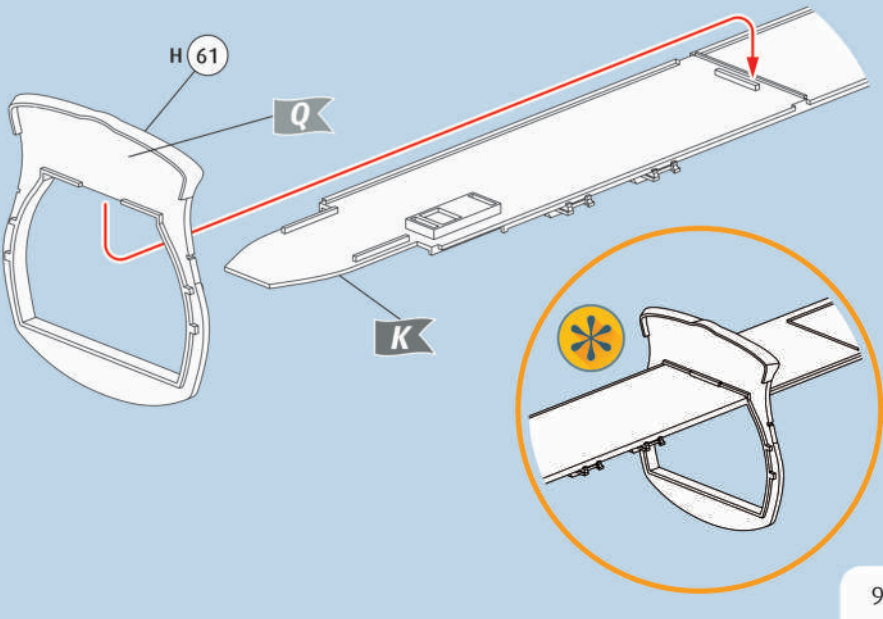

H 61
Q
K

3   

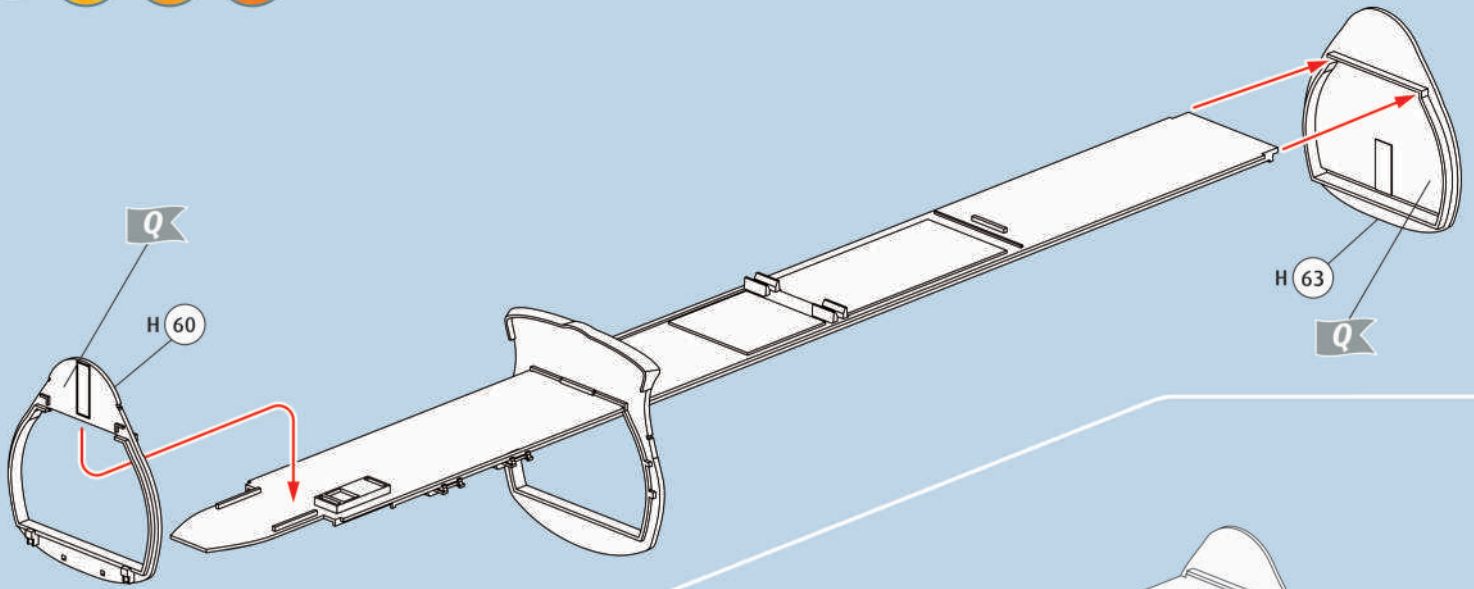

4   

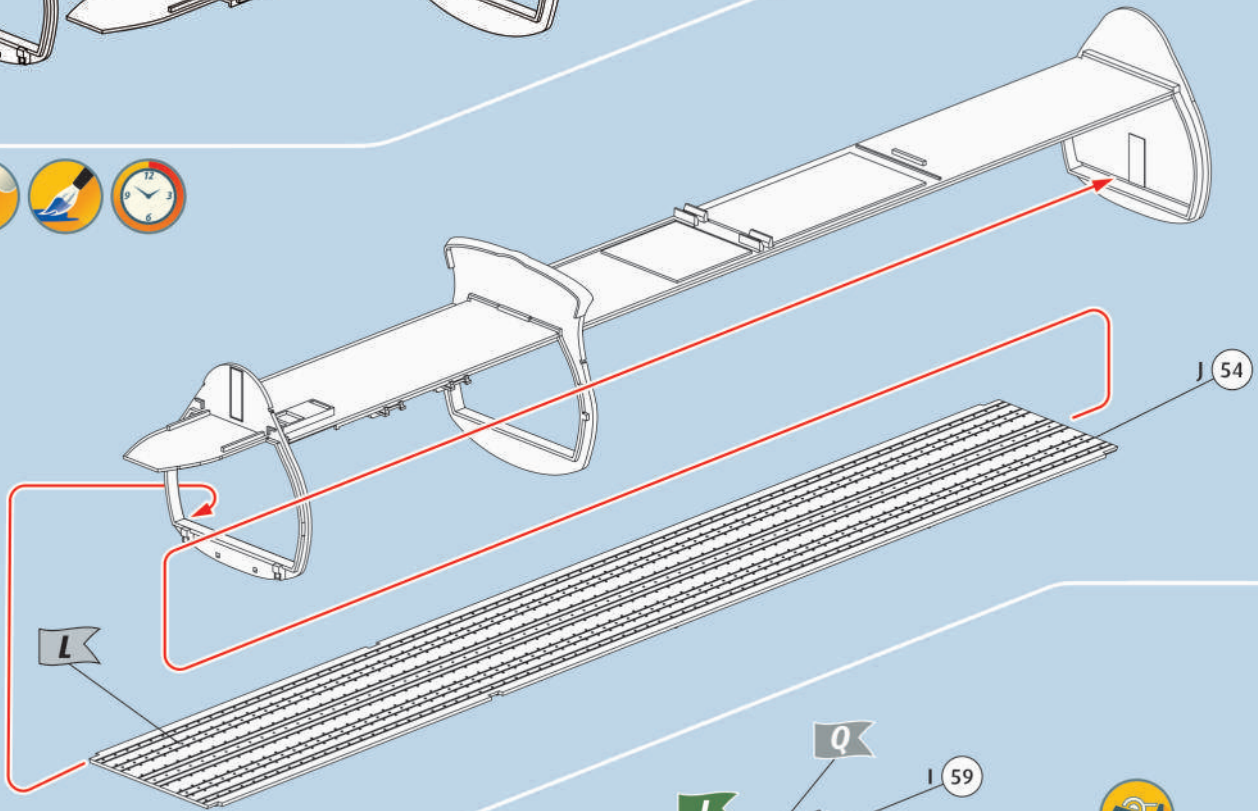

5   

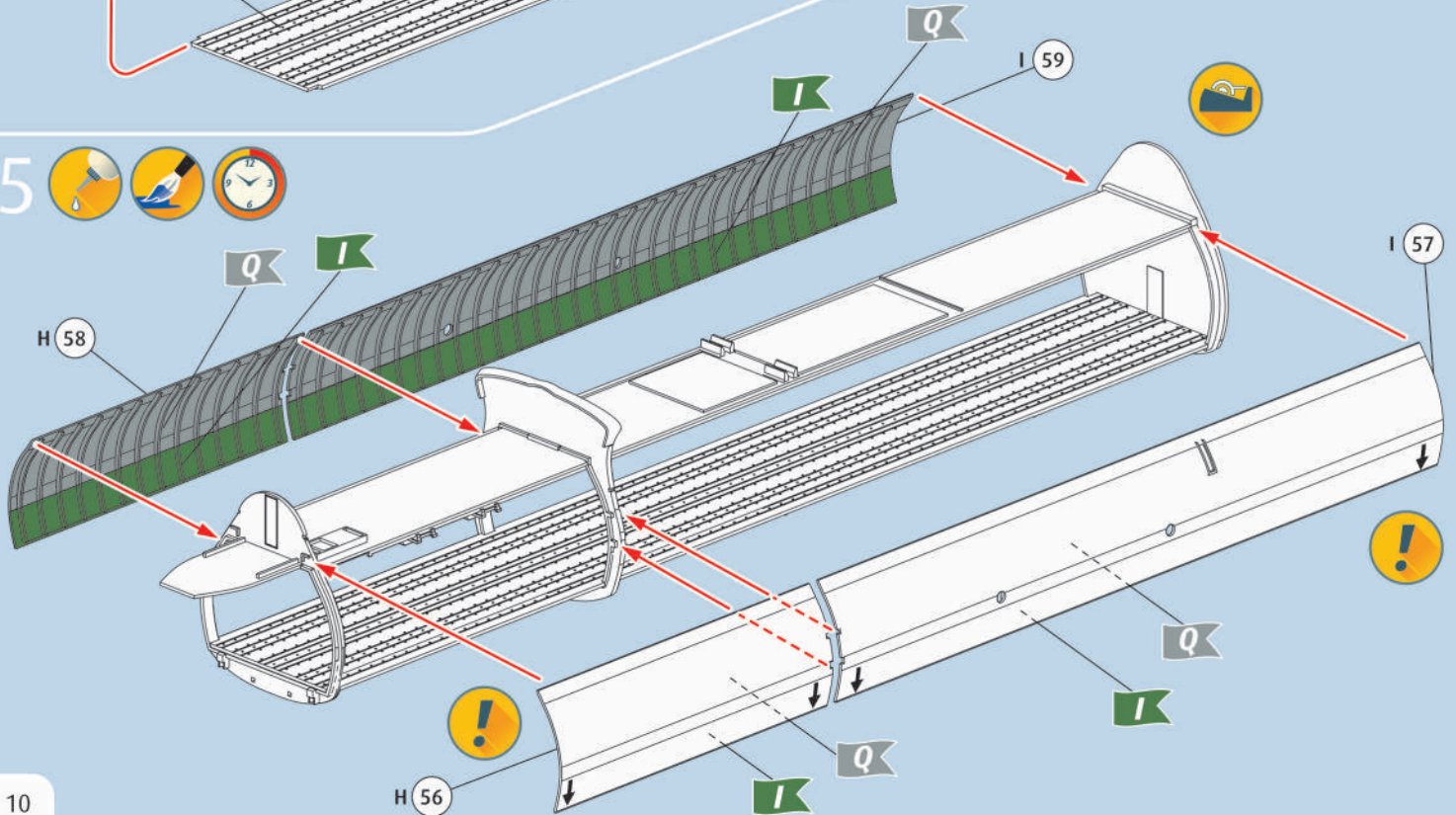

6   

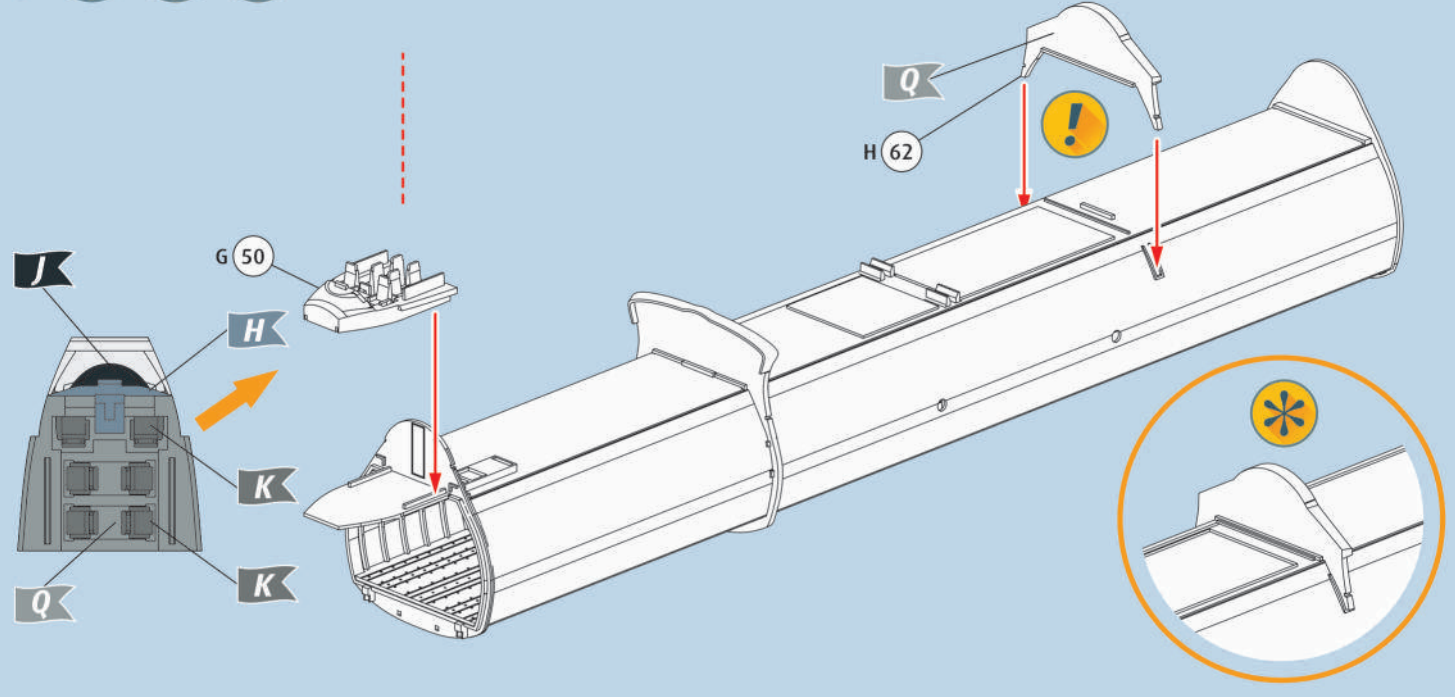

7   

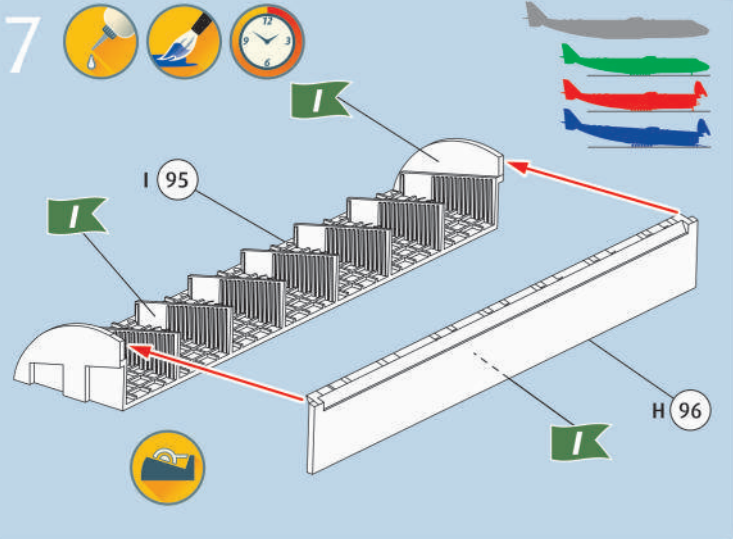

8   

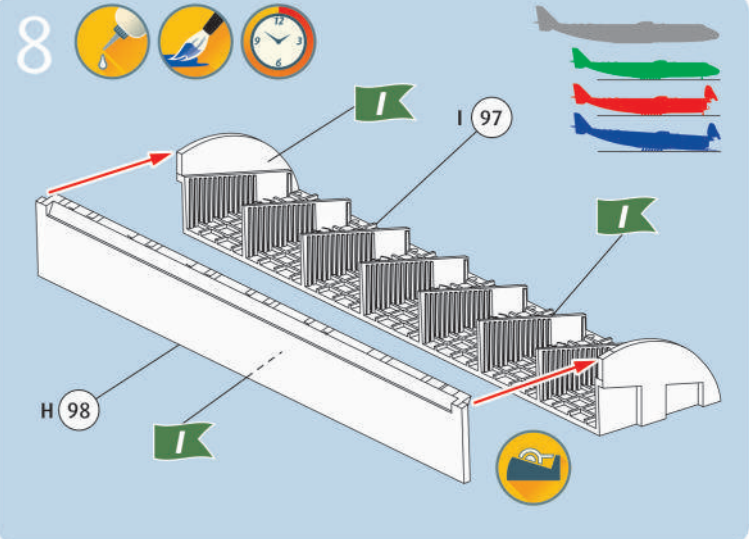

9    

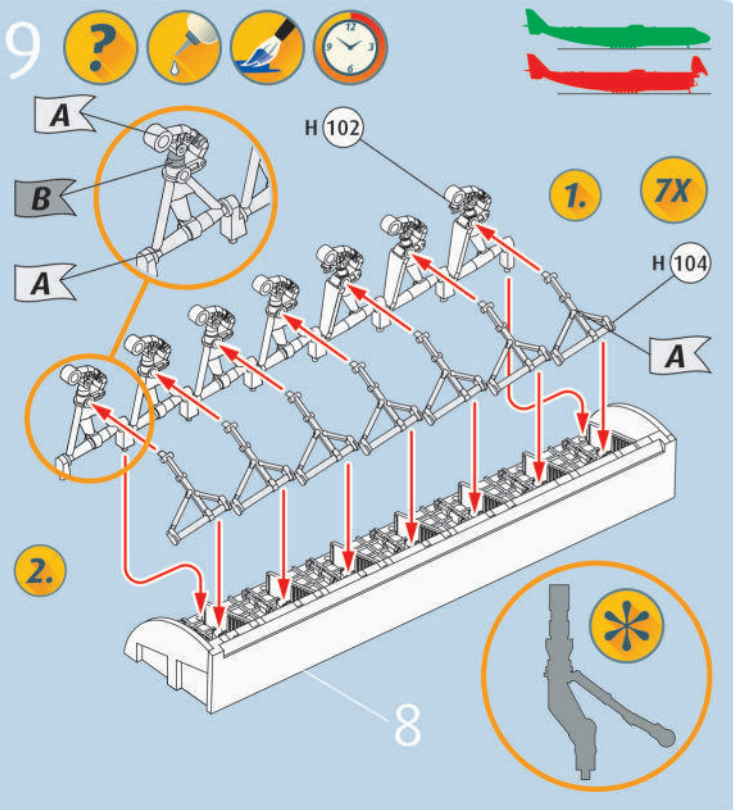

10    

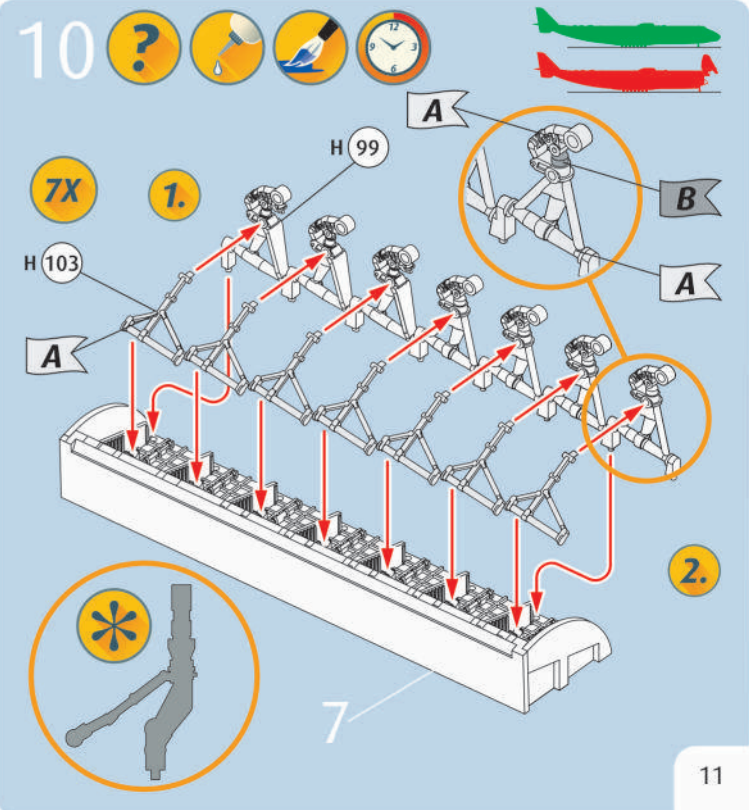

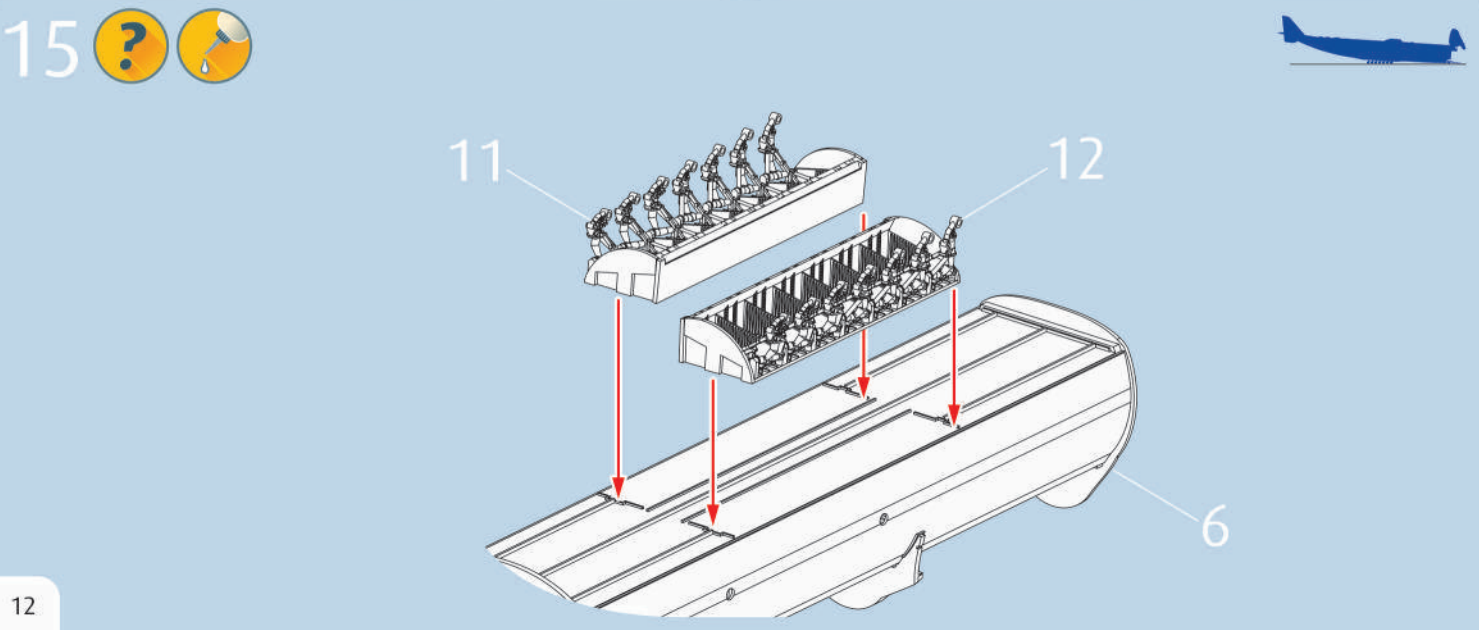
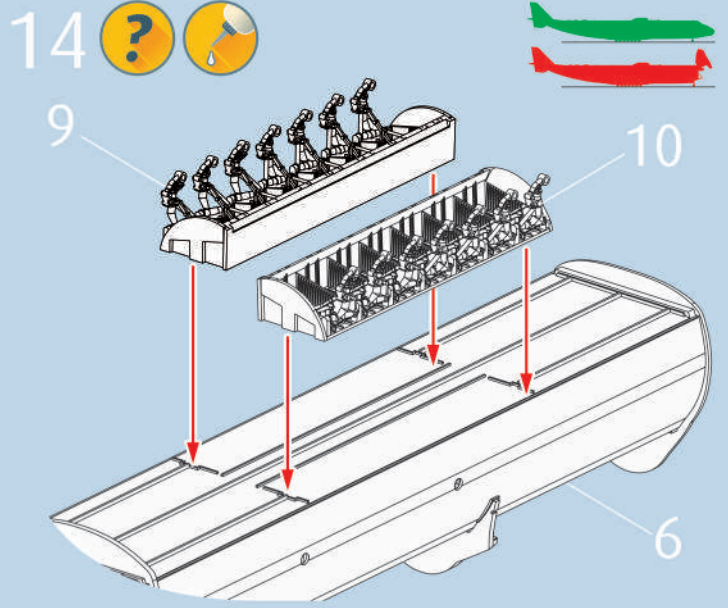
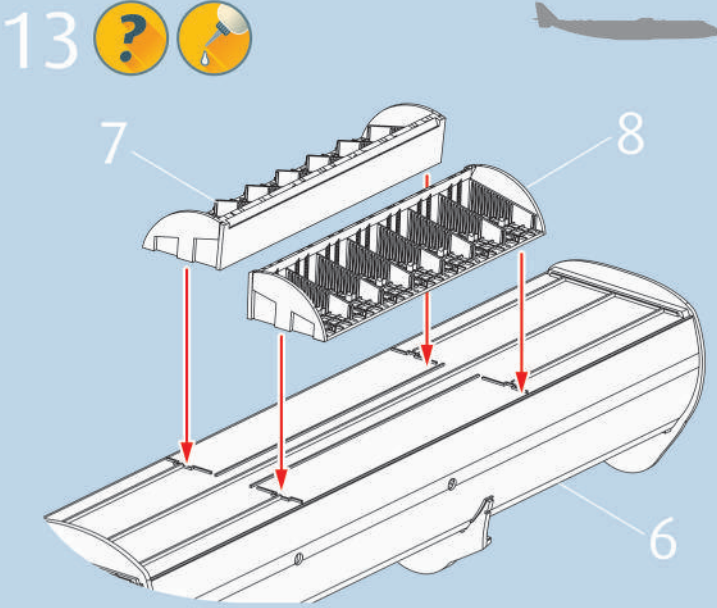
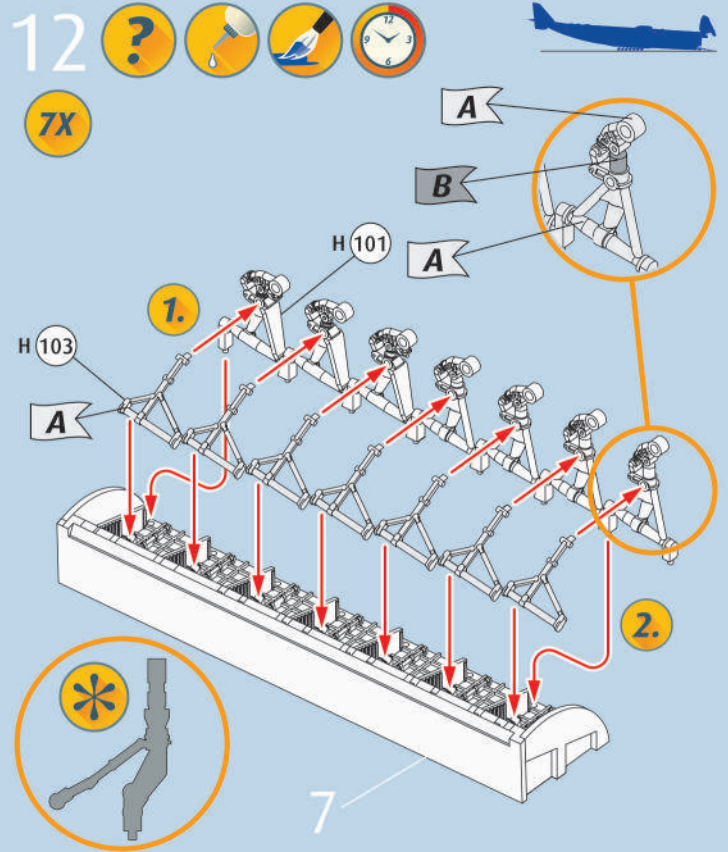
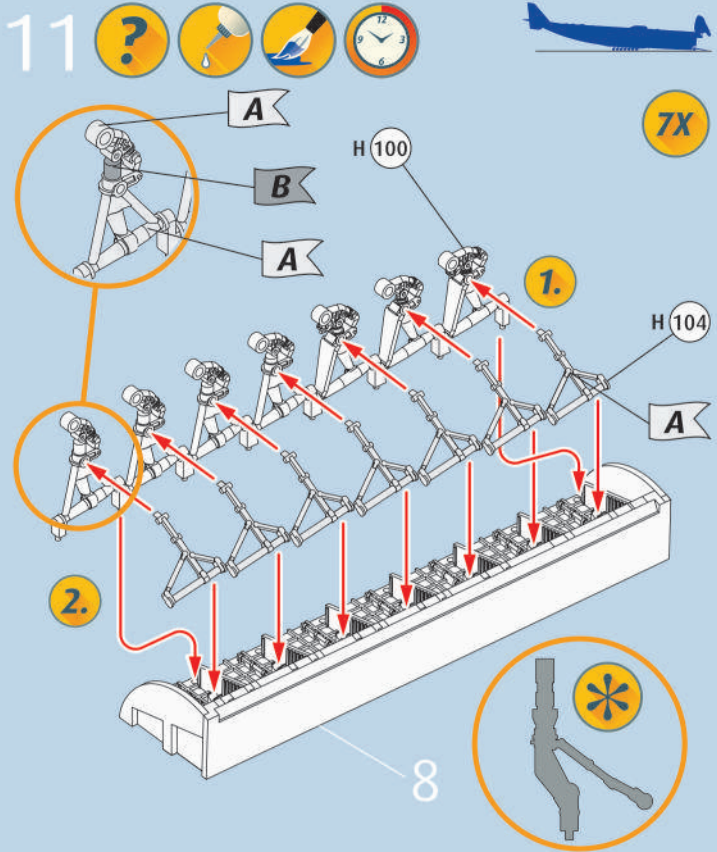

16

38 34	35 36 37
33 39	40 41 42

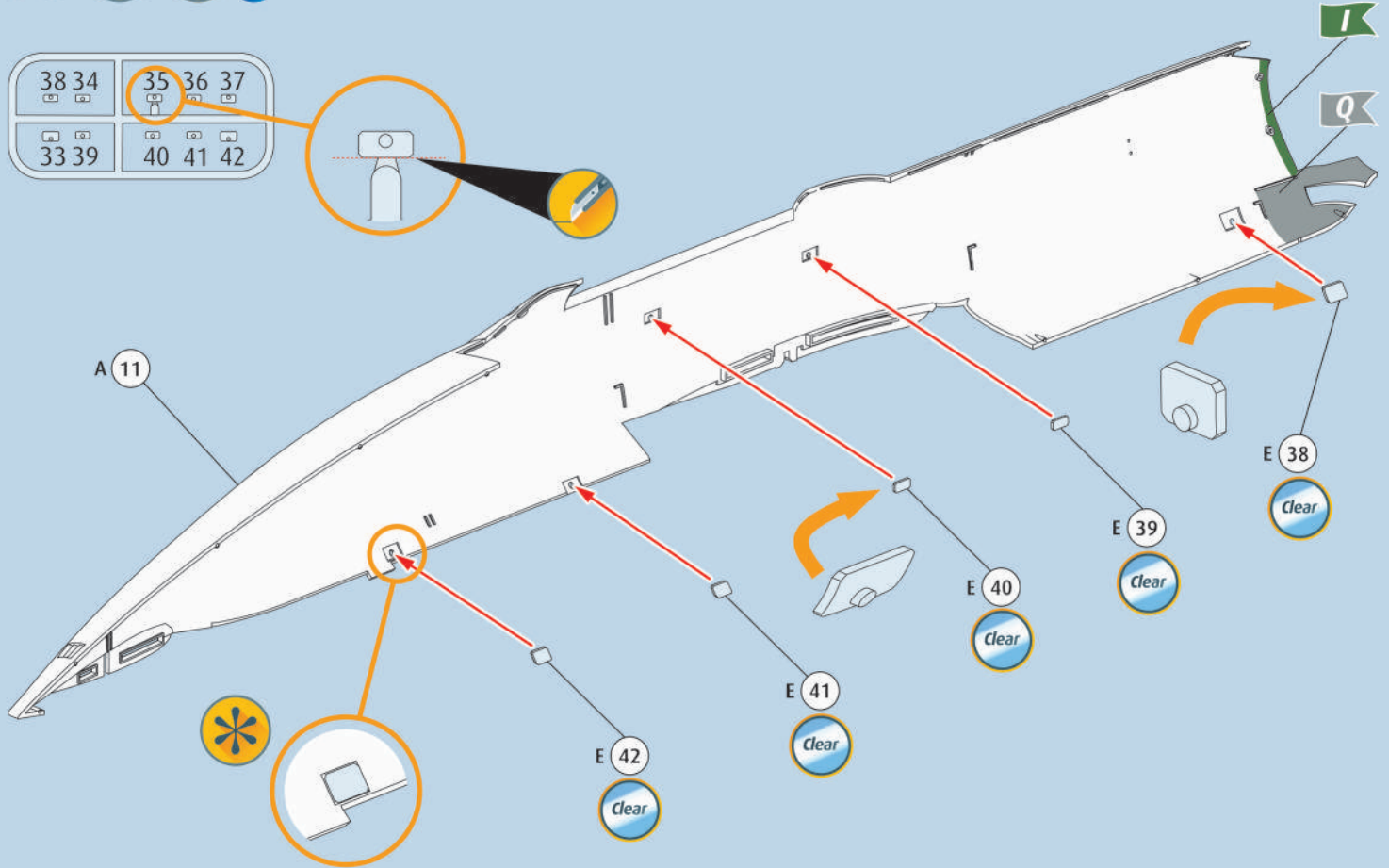

17

38 34	35 36 37
33 39	40 41 42

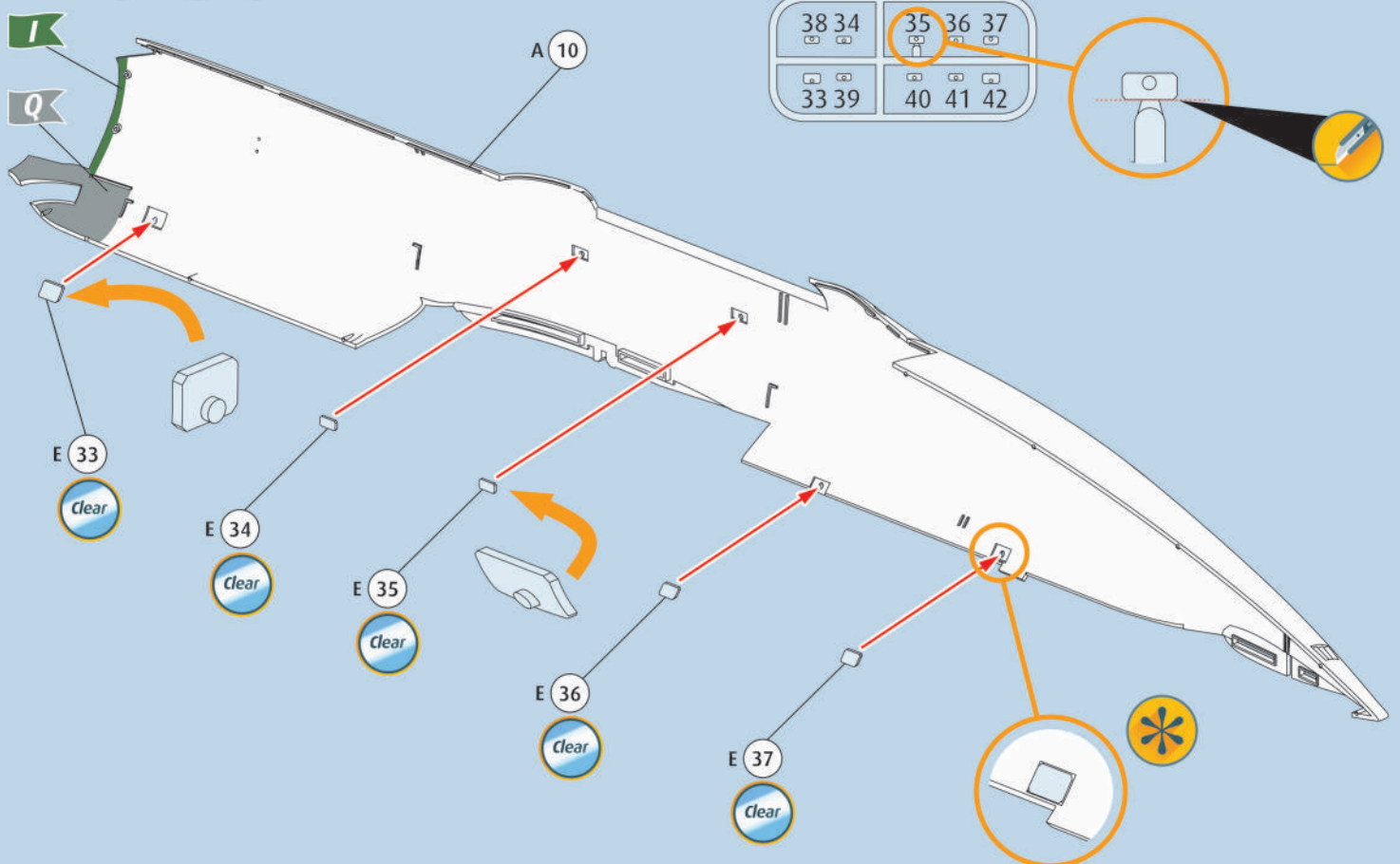

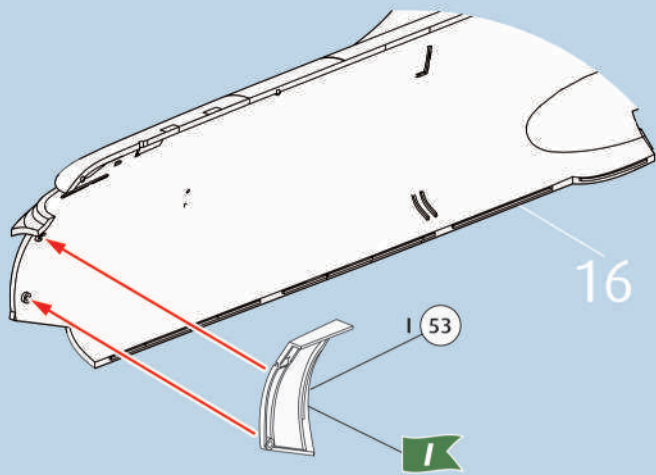
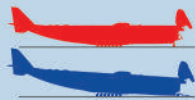
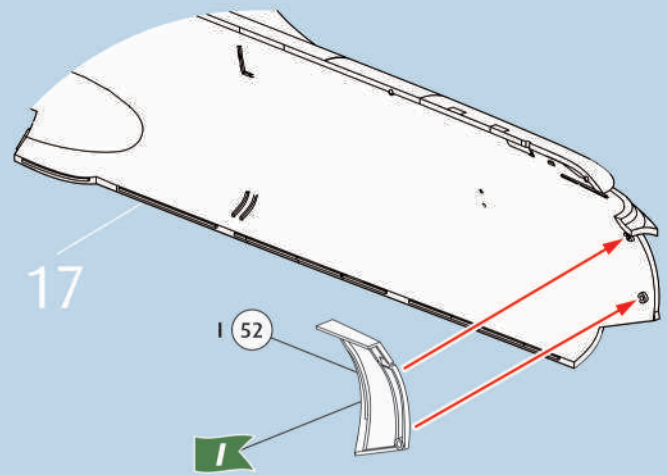
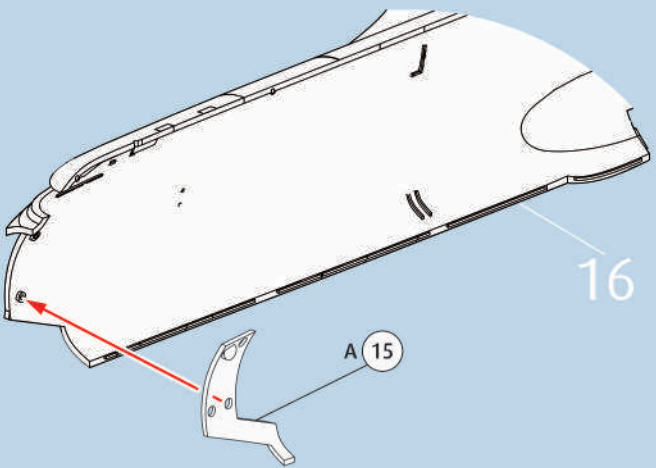
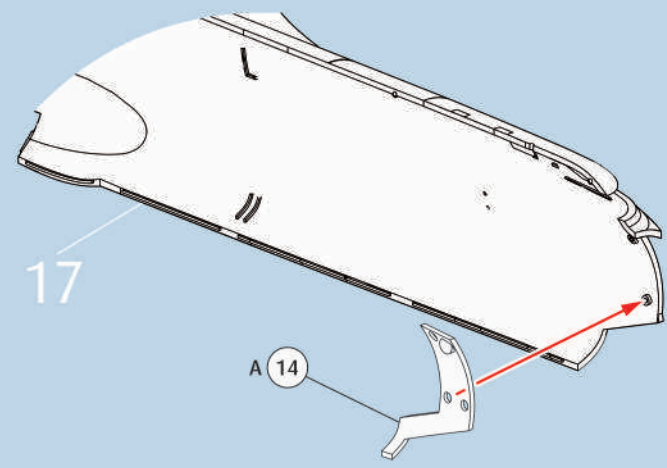
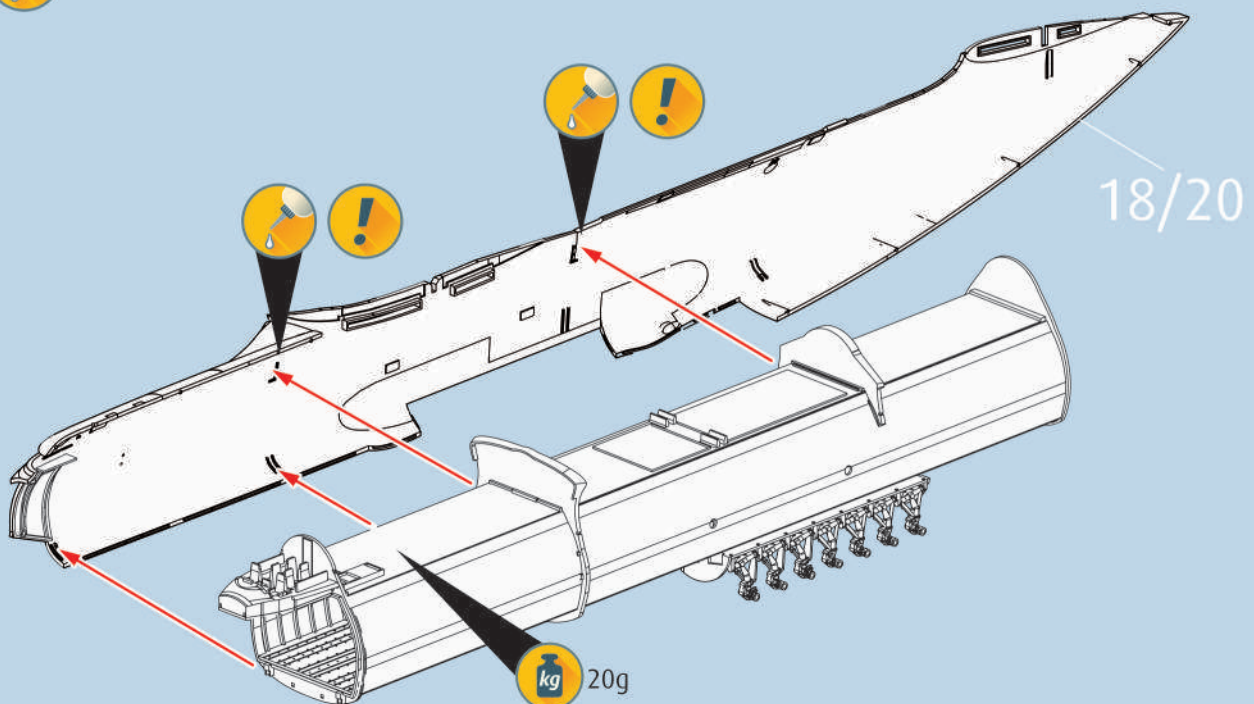
18 ?  19 ?  20 ?  21 ?  22 

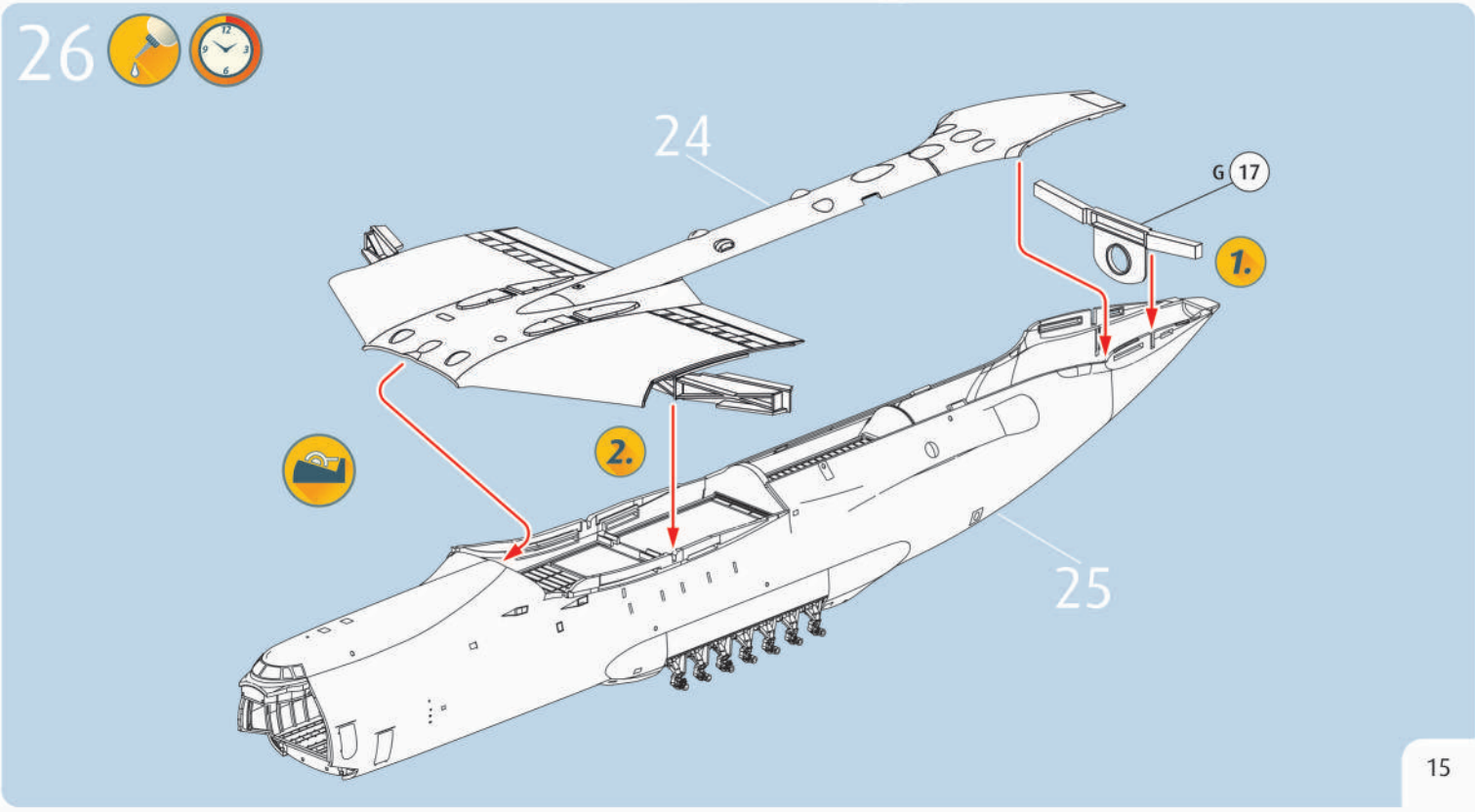
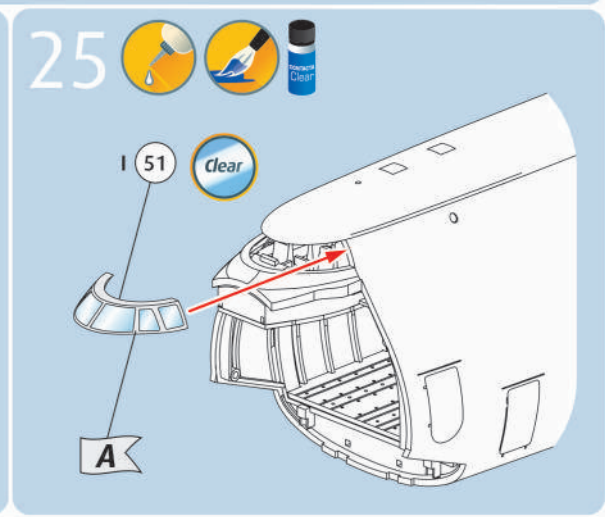
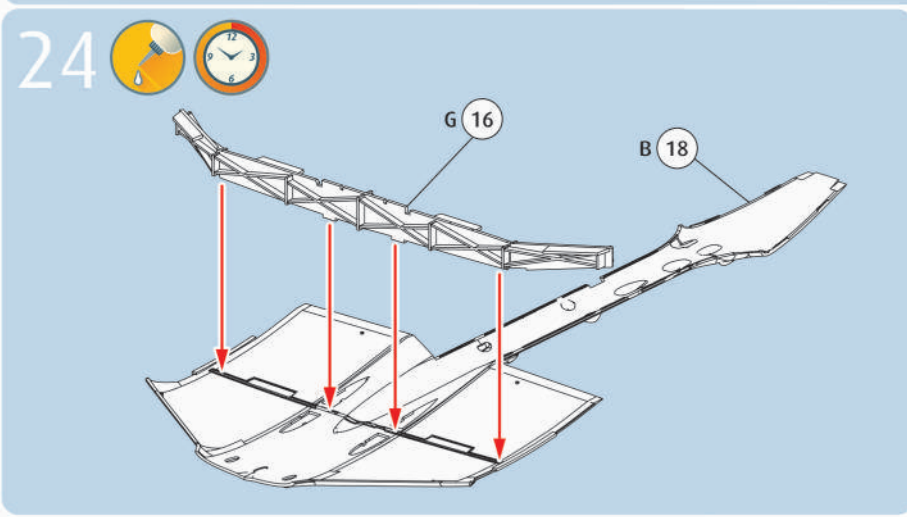
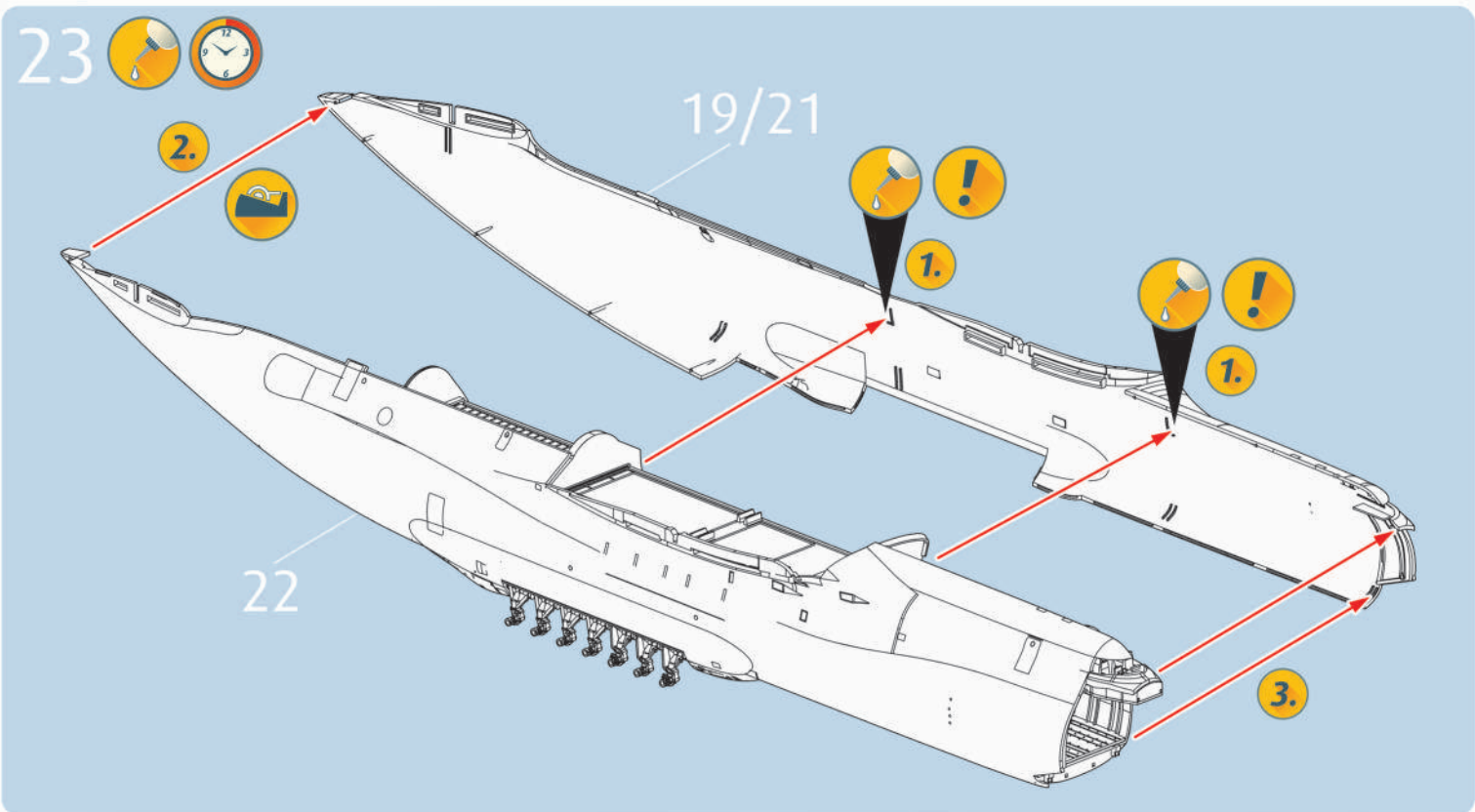

27

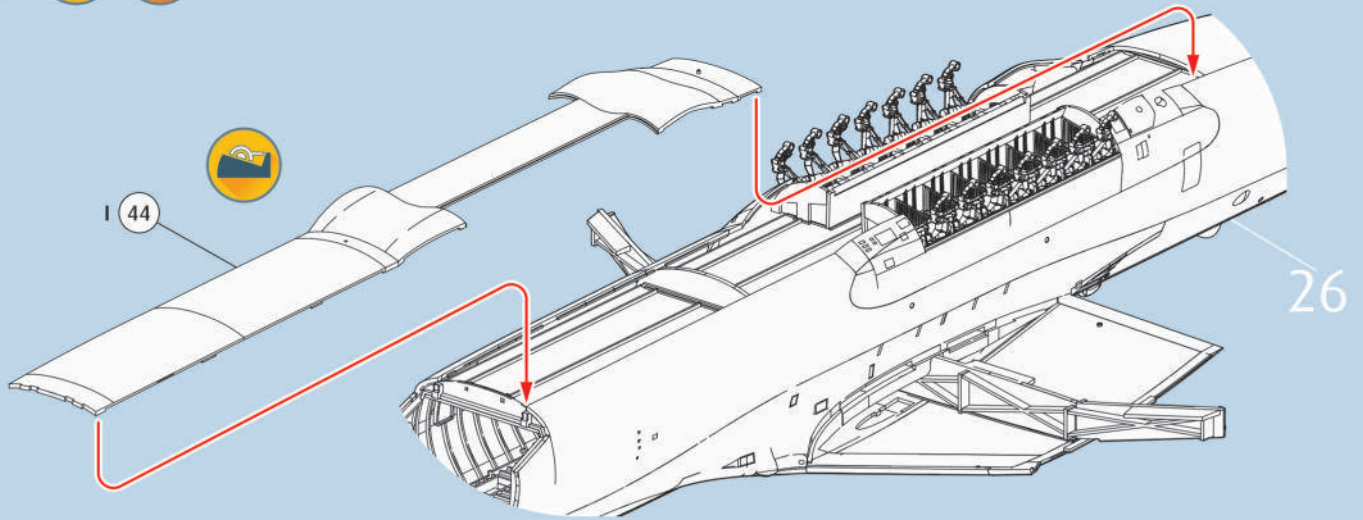

28

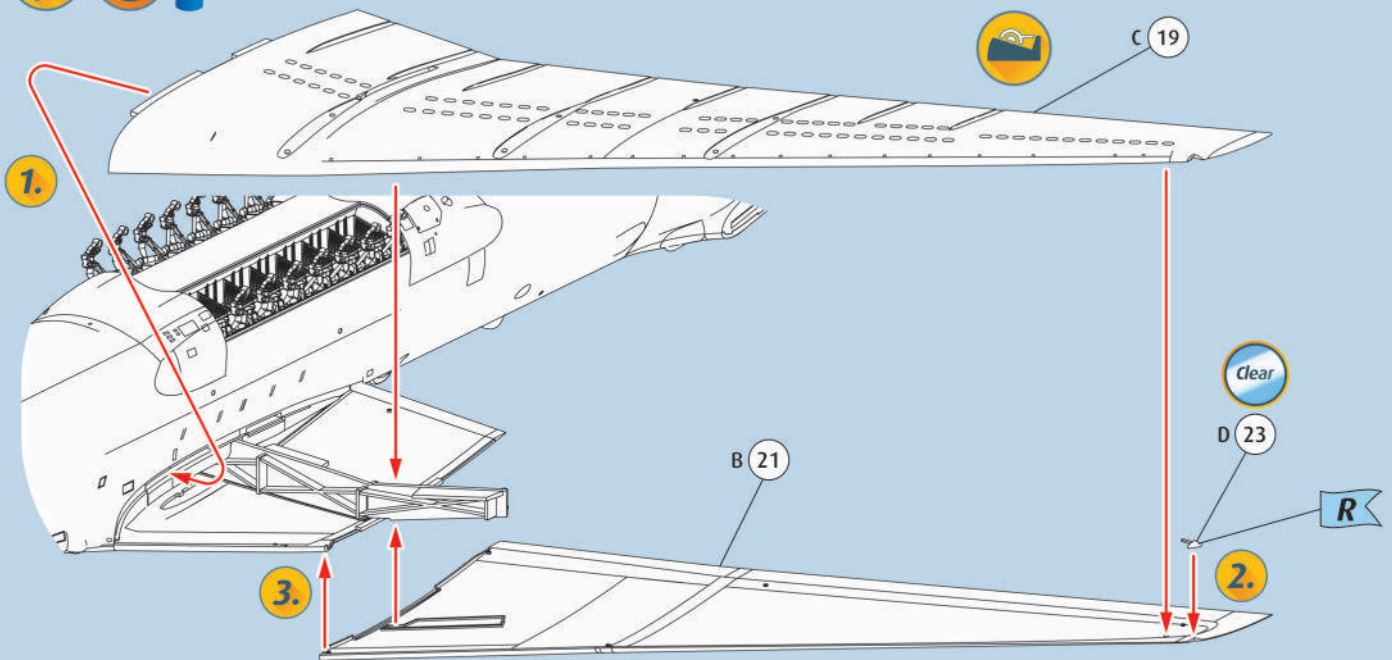

29

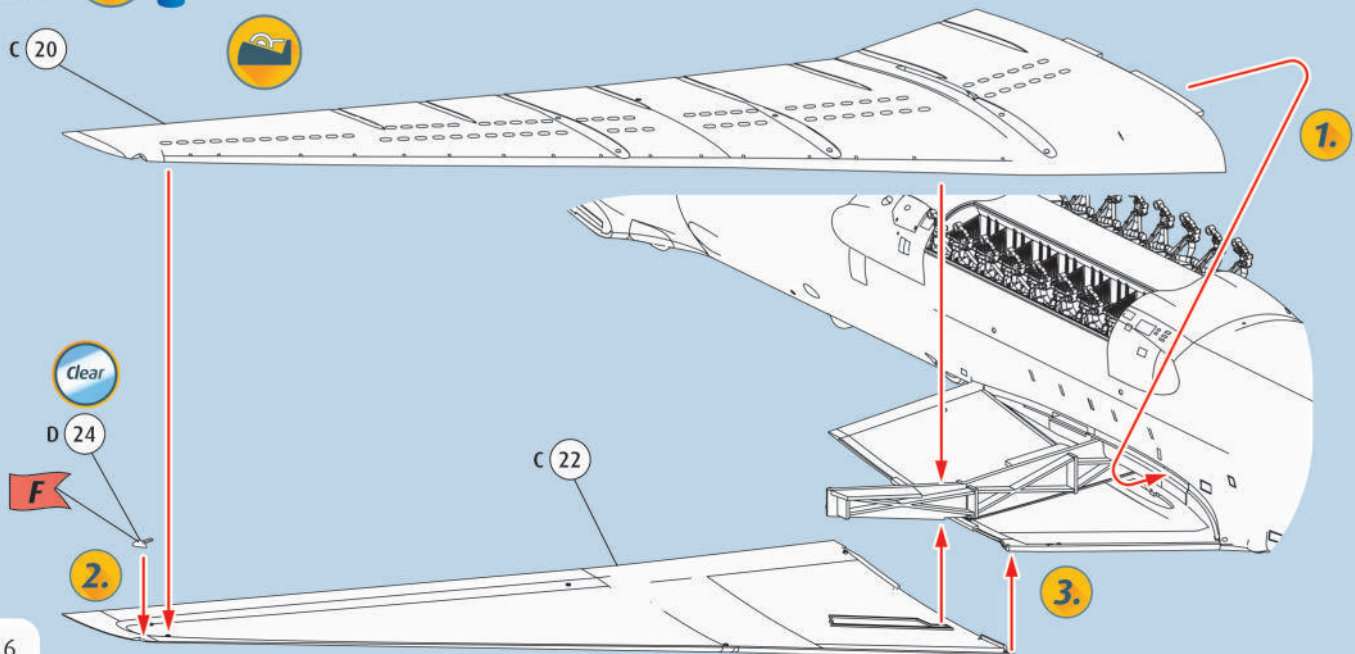

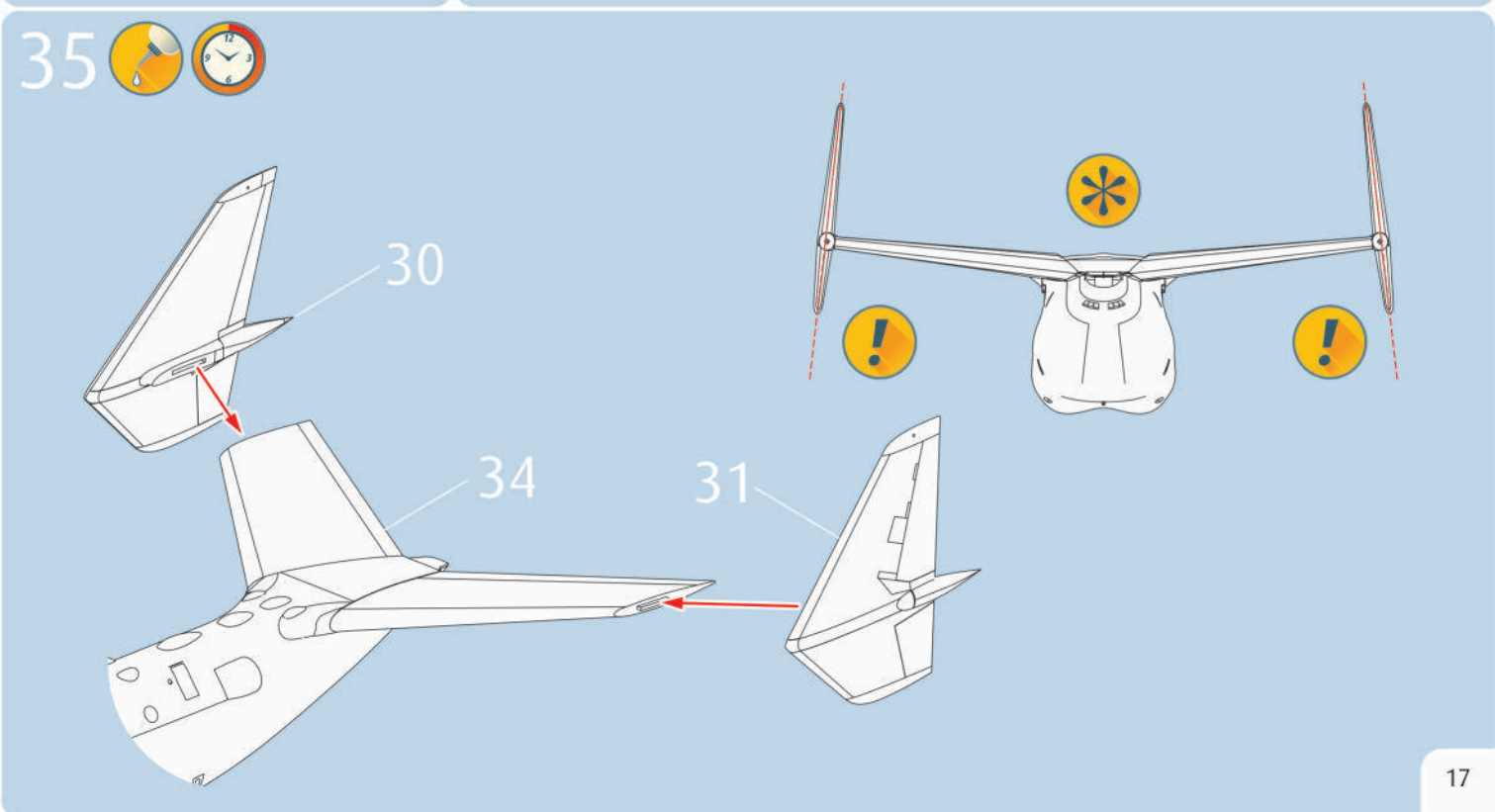
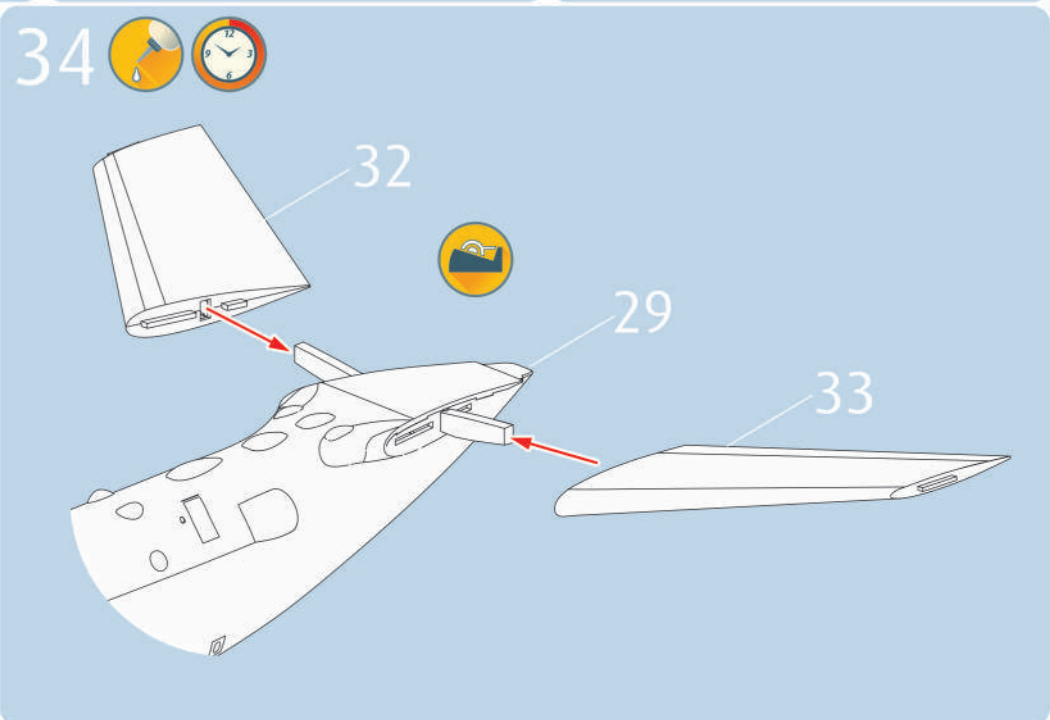
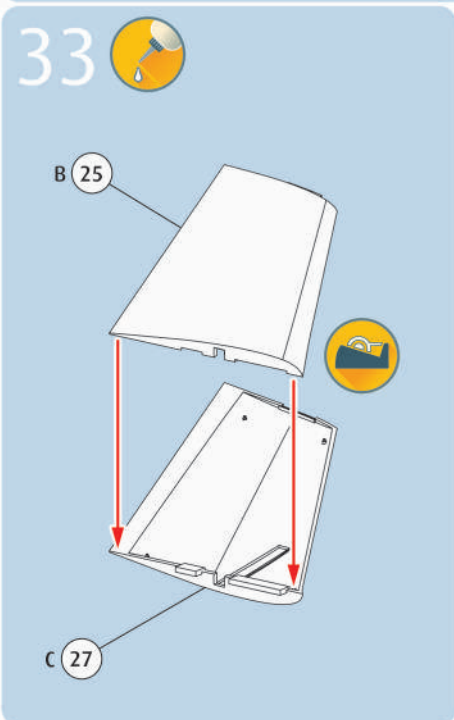
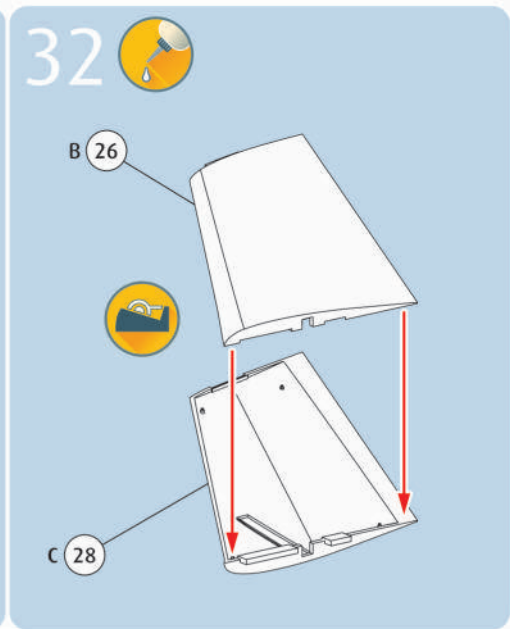
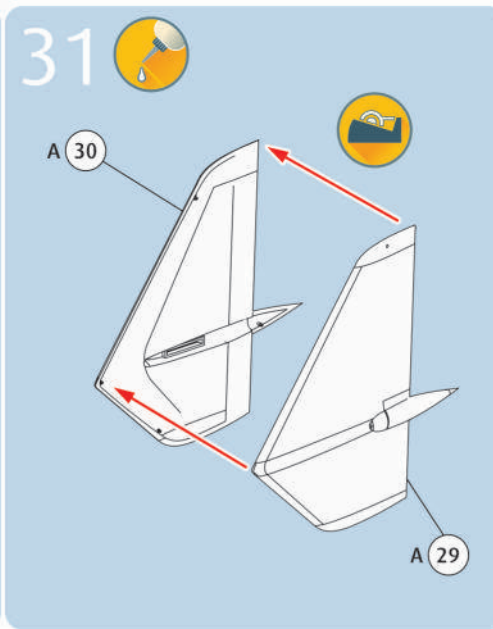
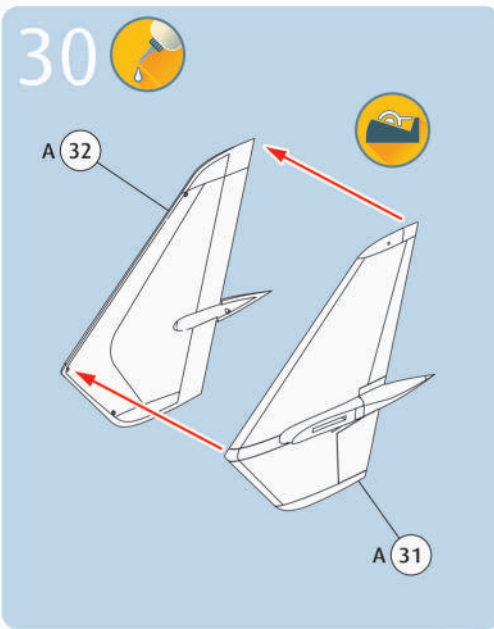

36   

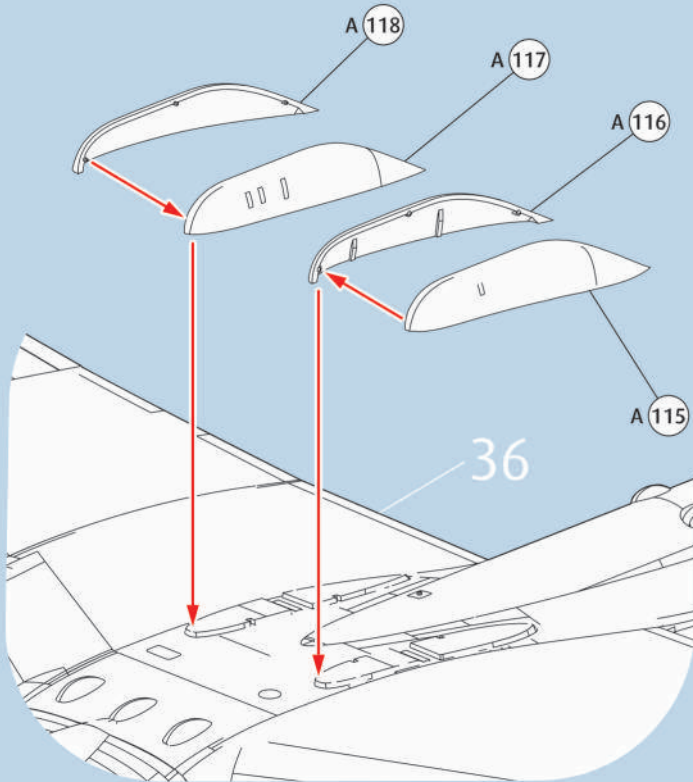

37    

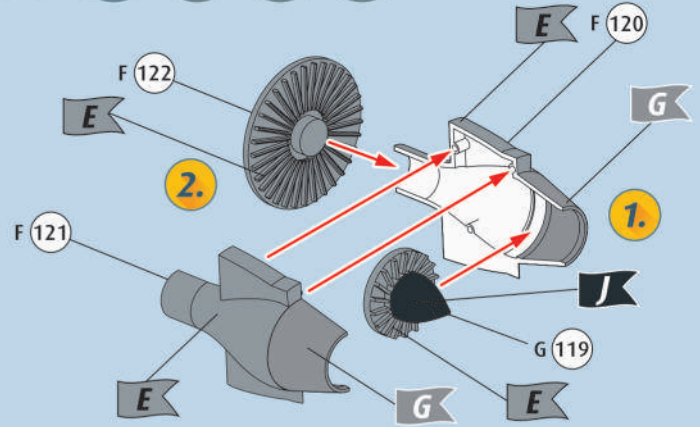

38    

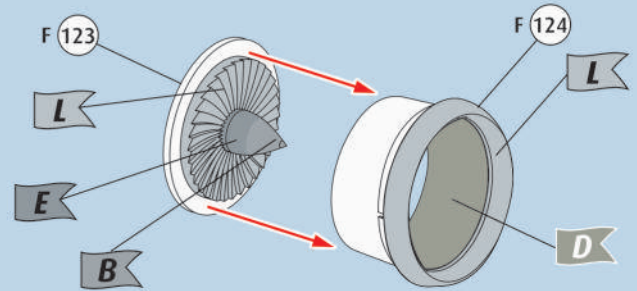

39   

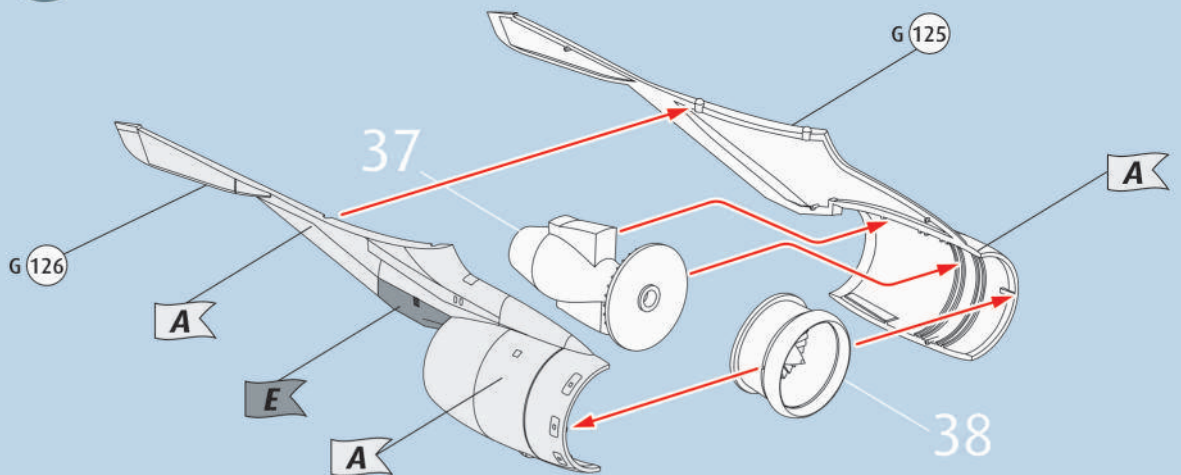

40   

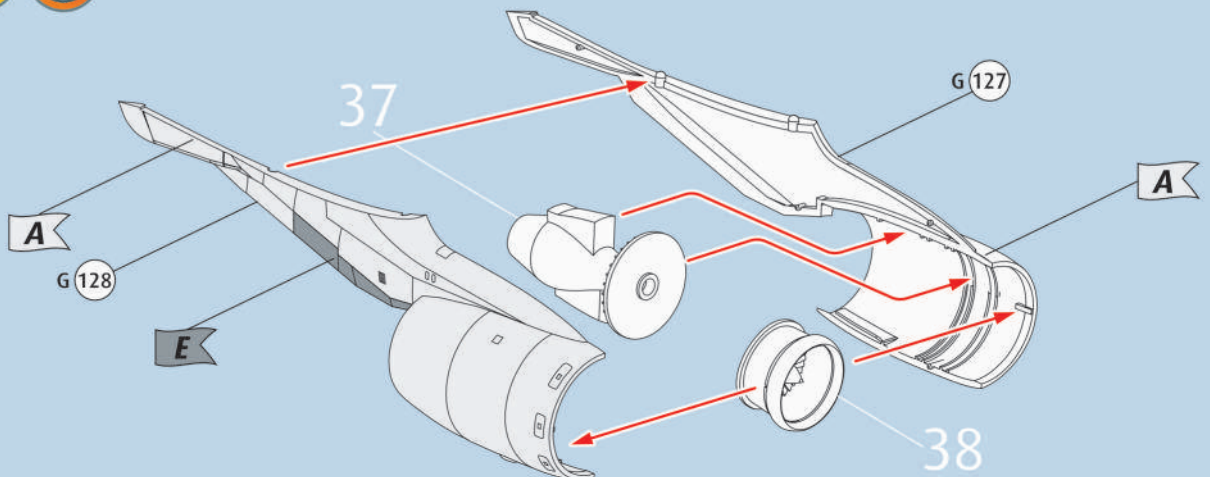

41  

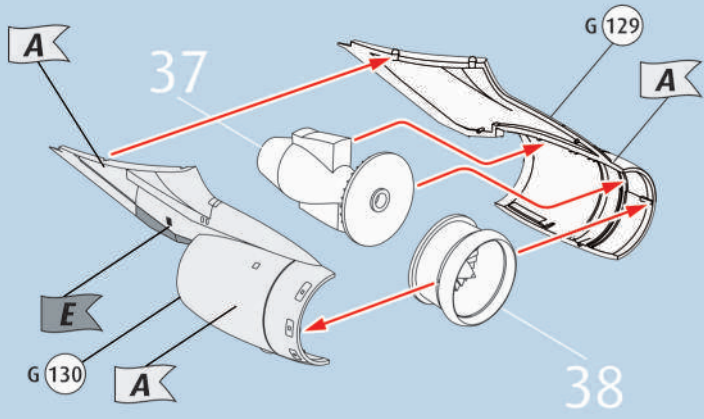

42  

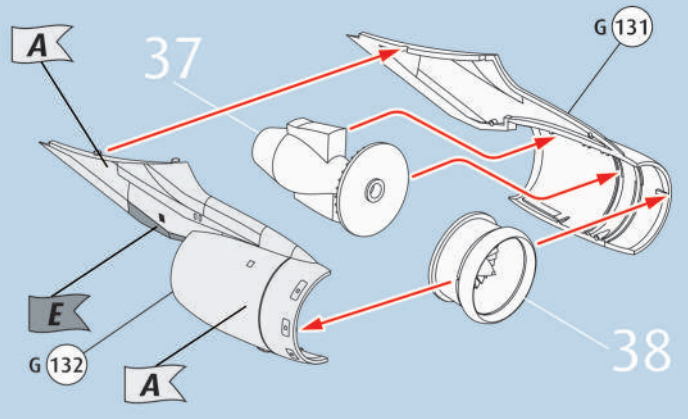

43  

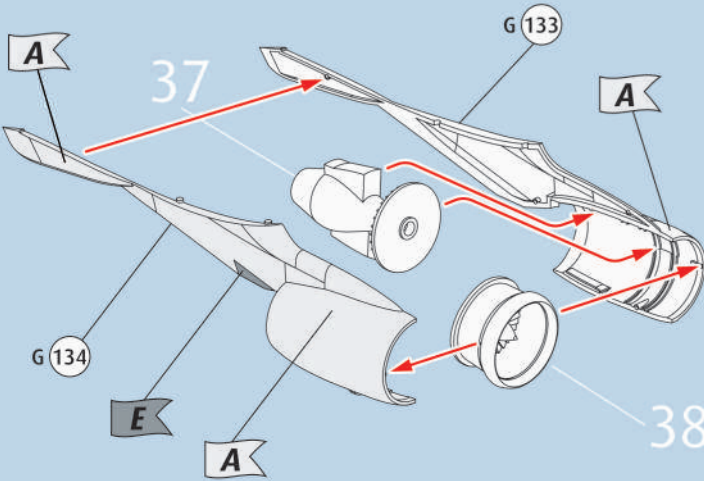

44  

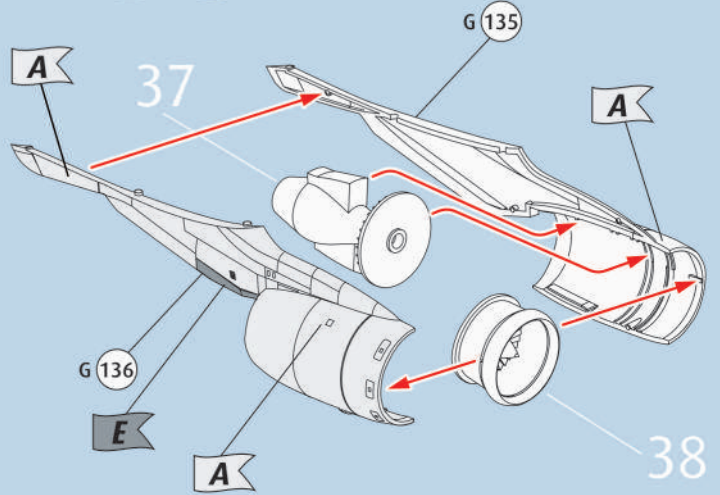

45 

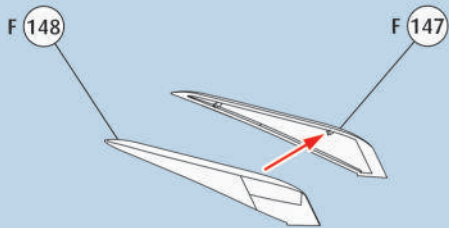

46 

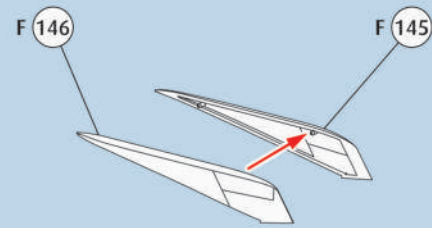

47 

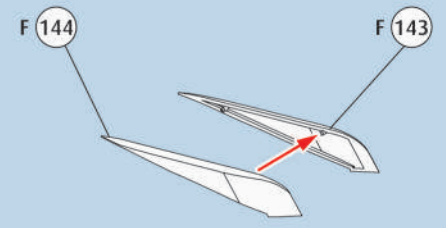

48 

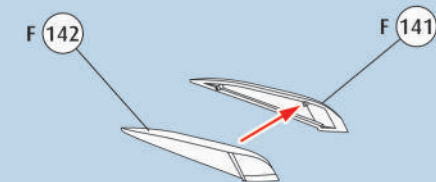

49 

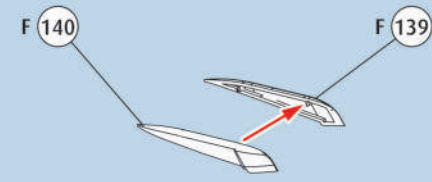

50 

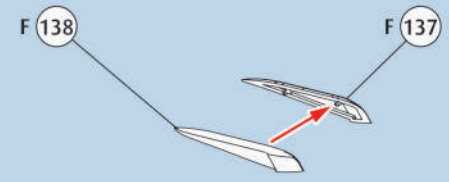

51  

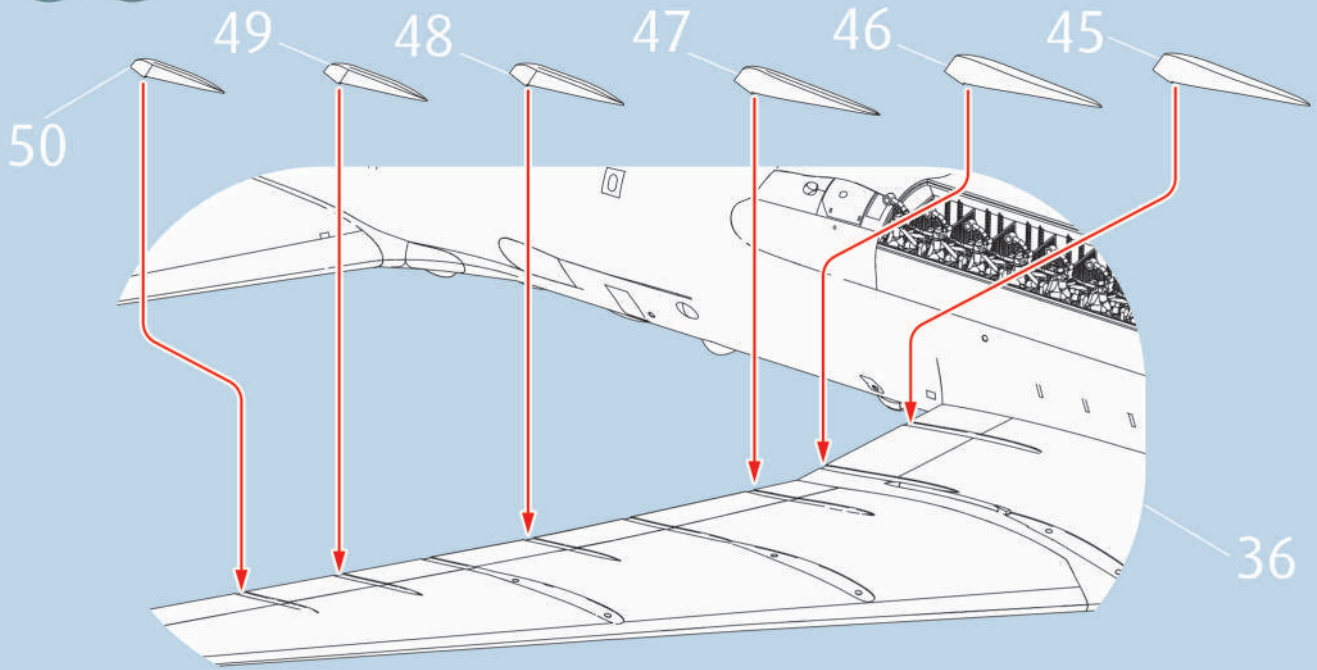

52 

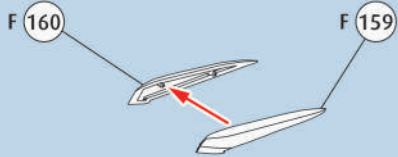

53 

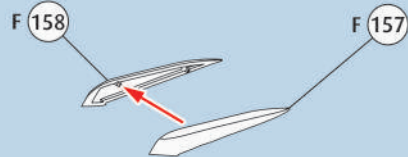

54 

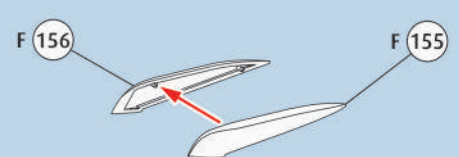

55 

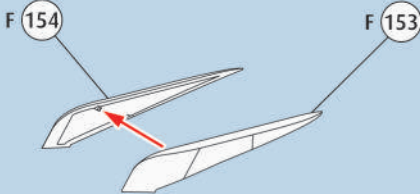

56 

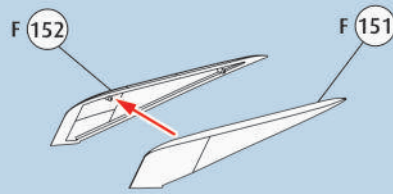

57 

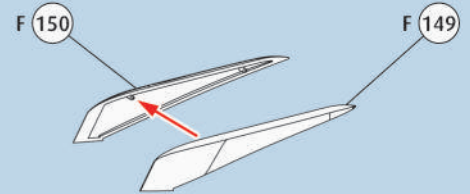

58  

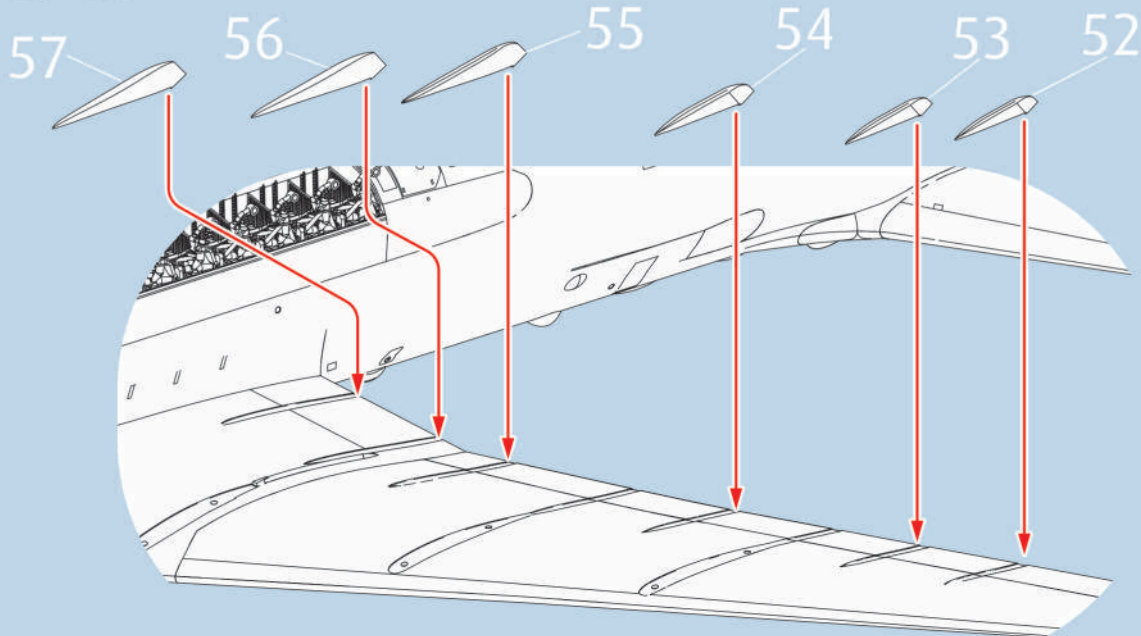

59   

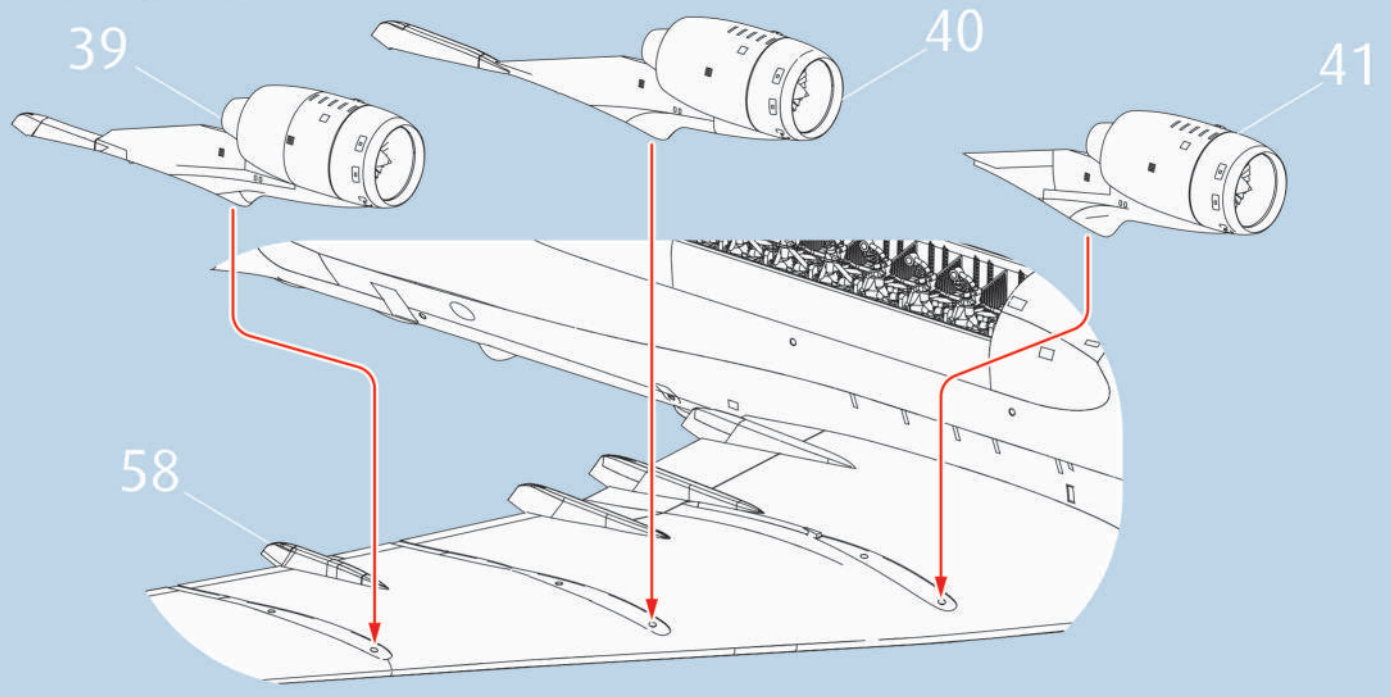

60   

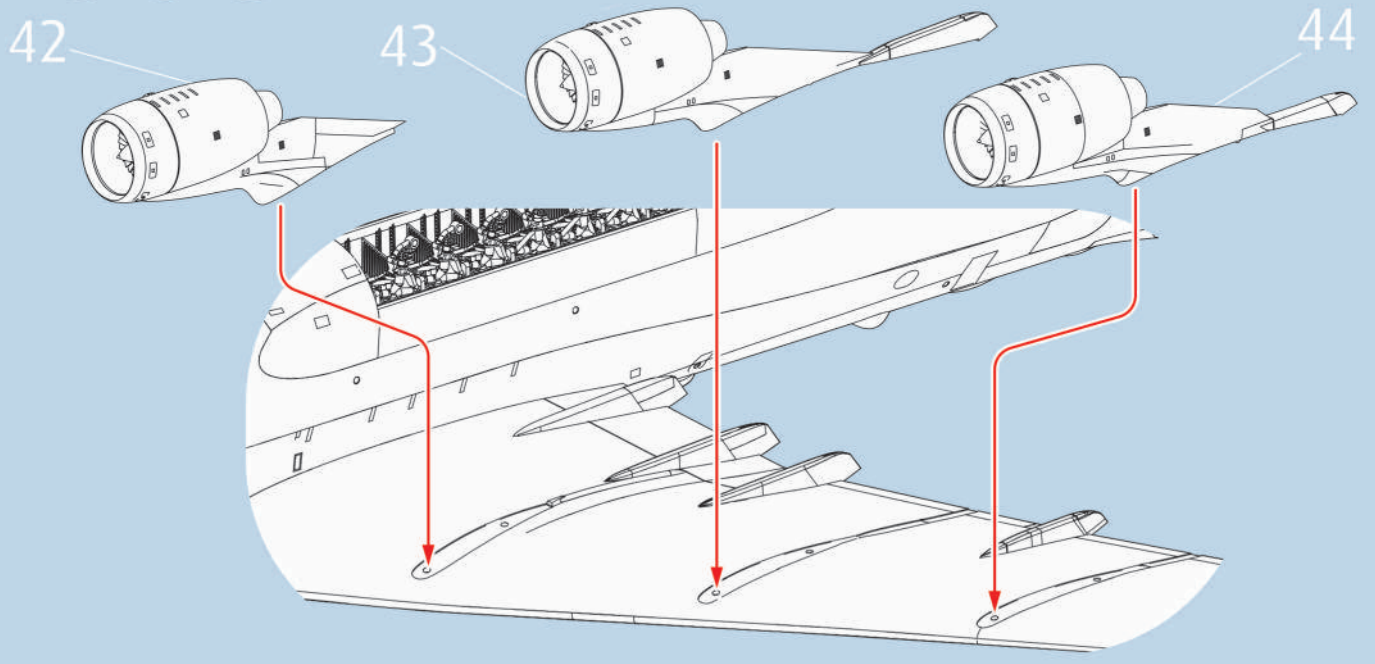

61    

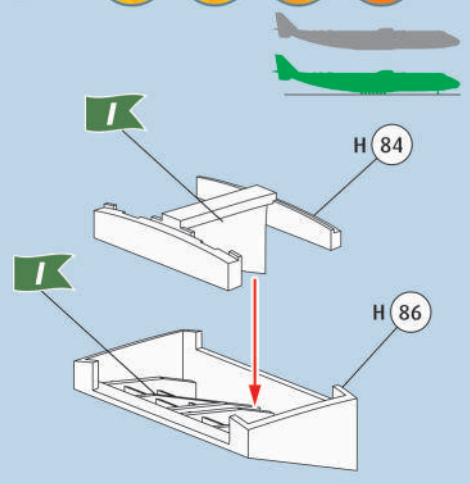

62    

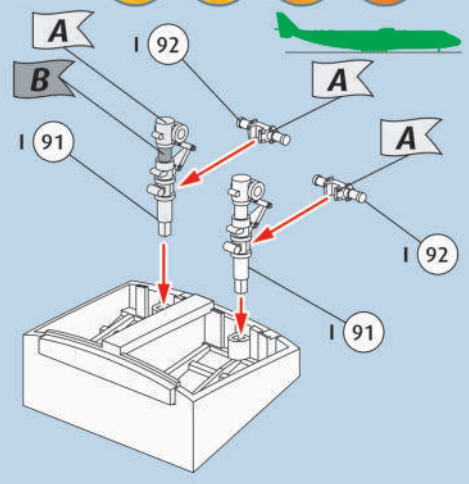

63   

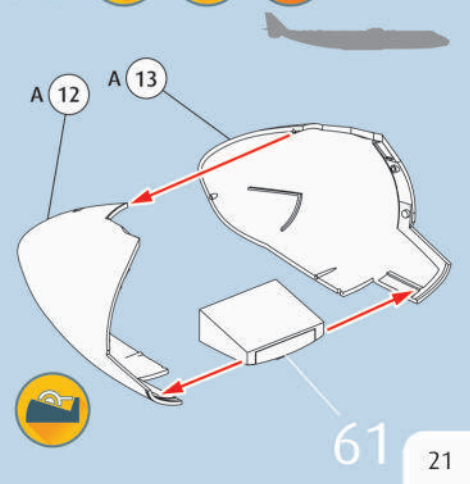

64 ?  

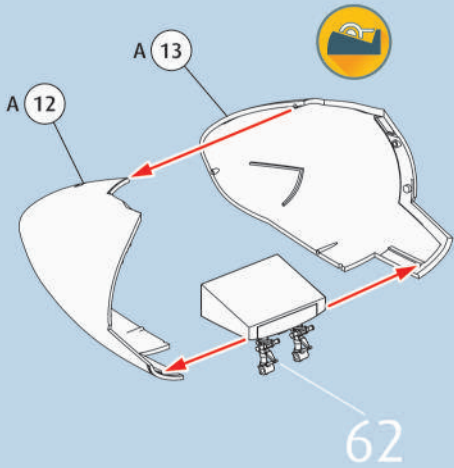

65 ?  

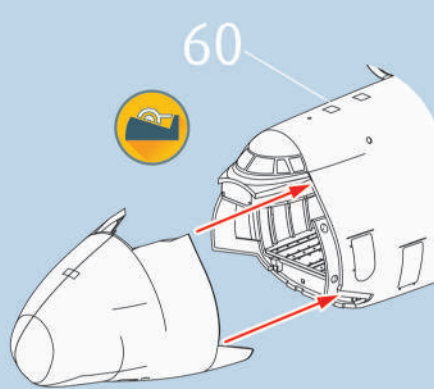

66 ?  

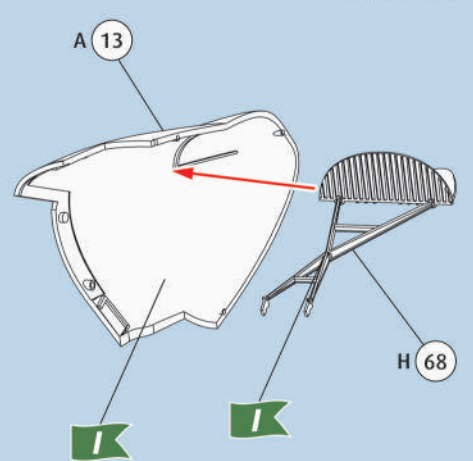
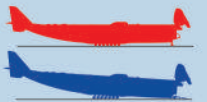

67 ?  

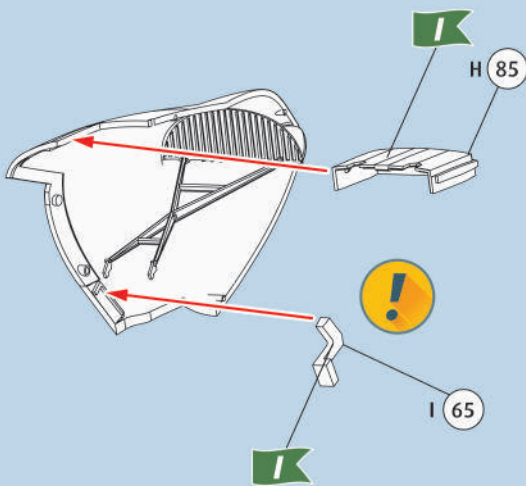
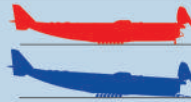

68 ?   

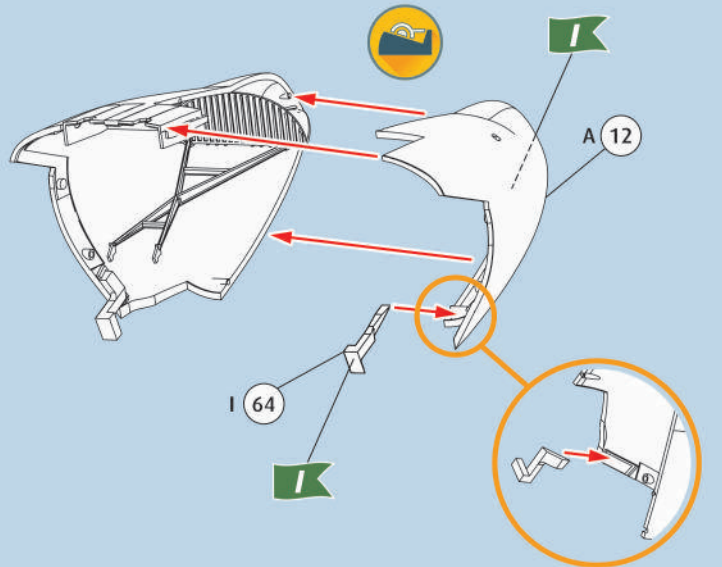

69 ?  

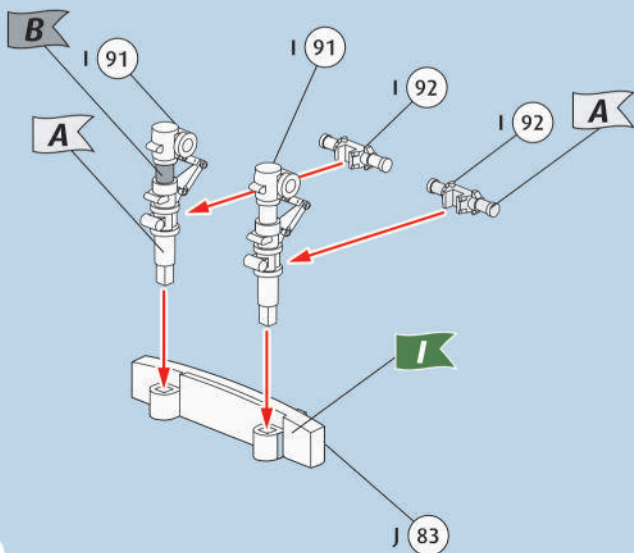

70 ?   

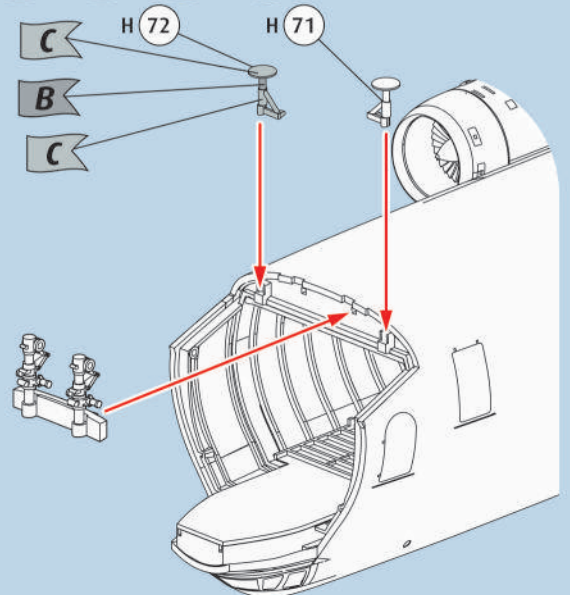

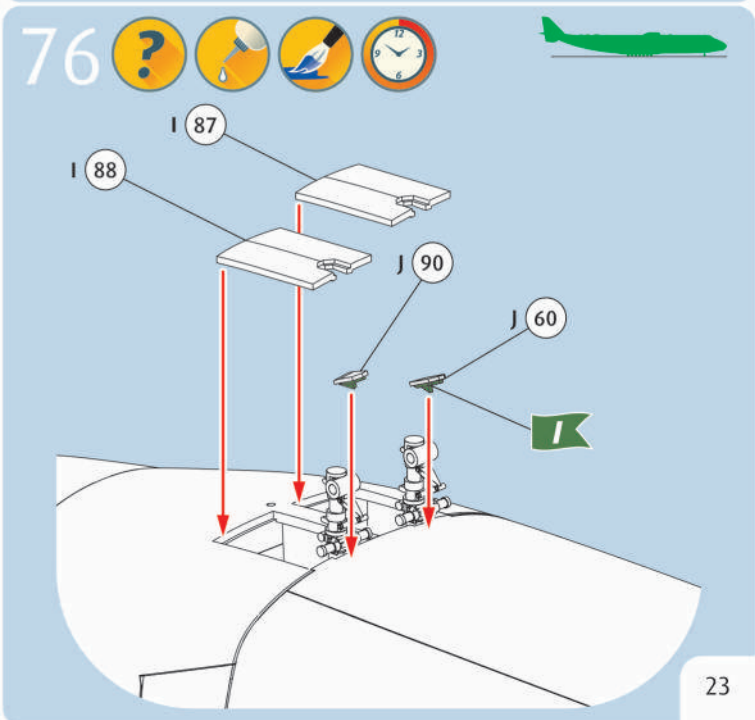
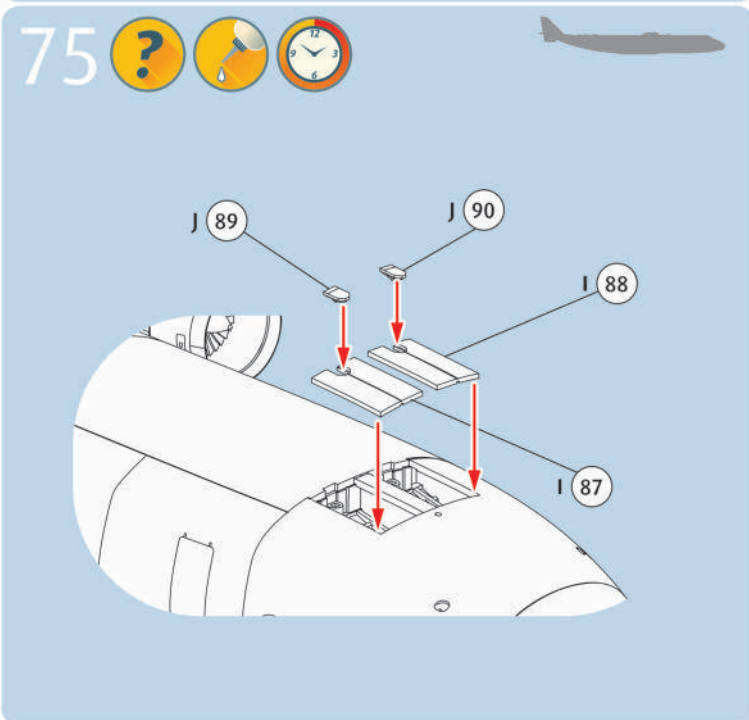
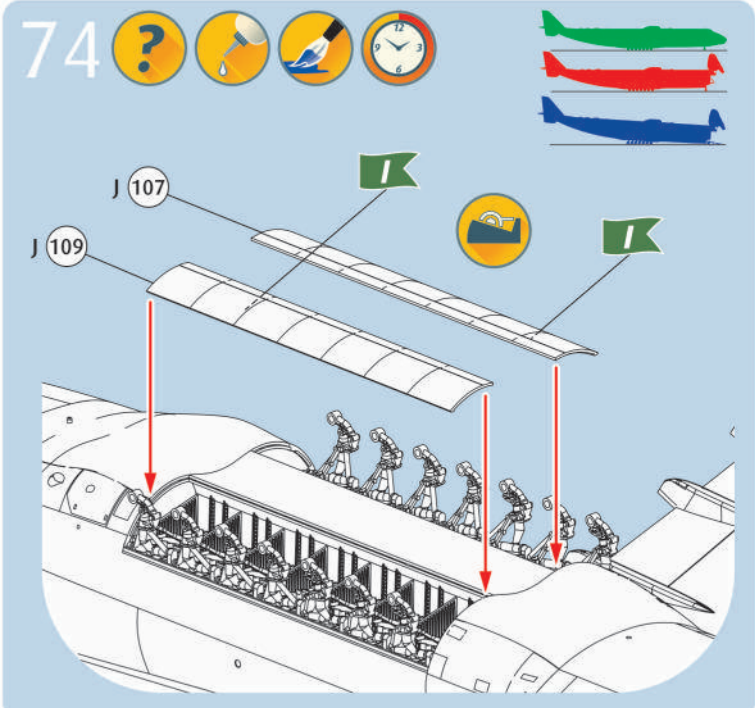
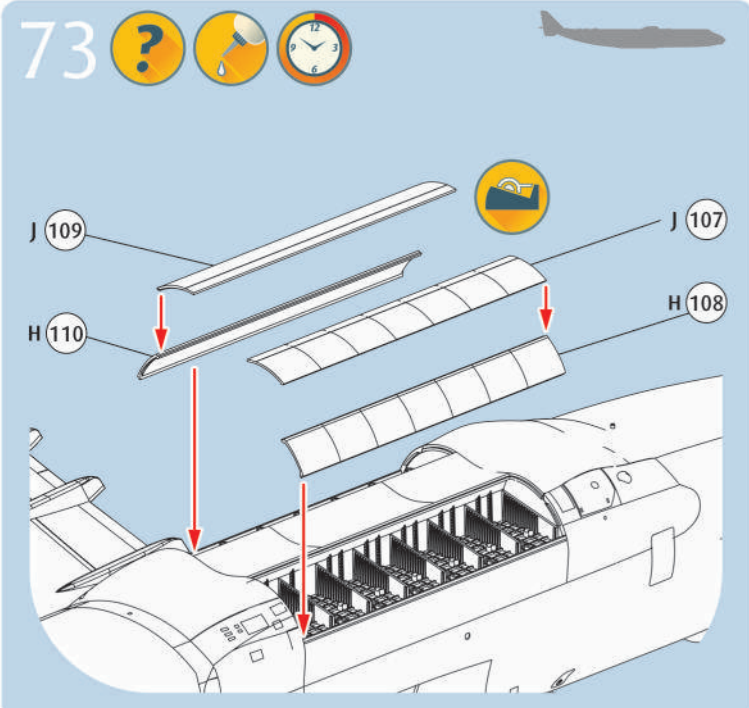
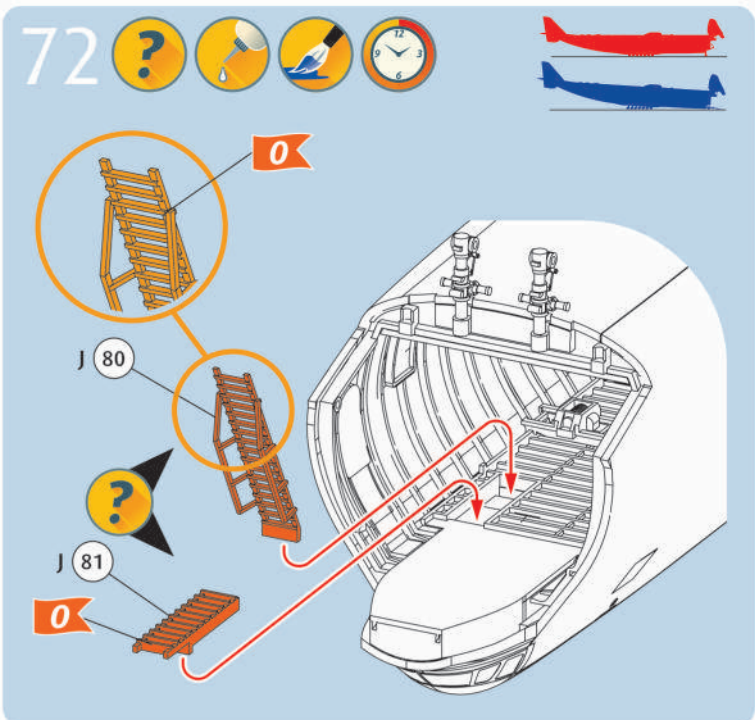
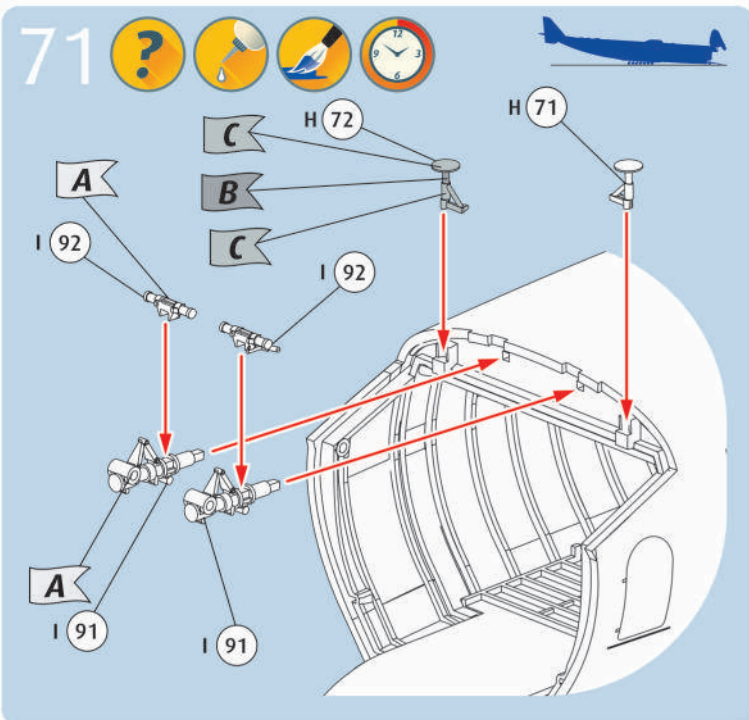

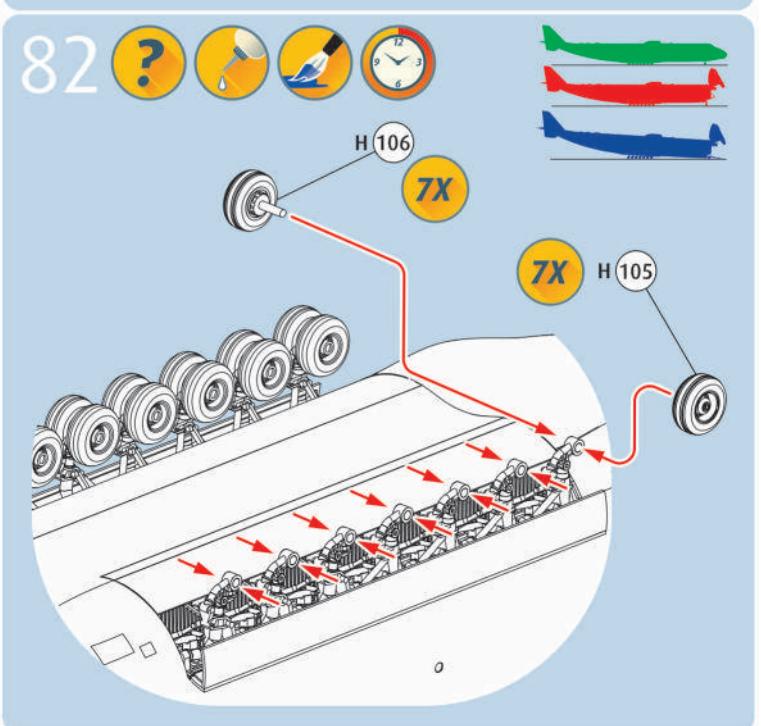
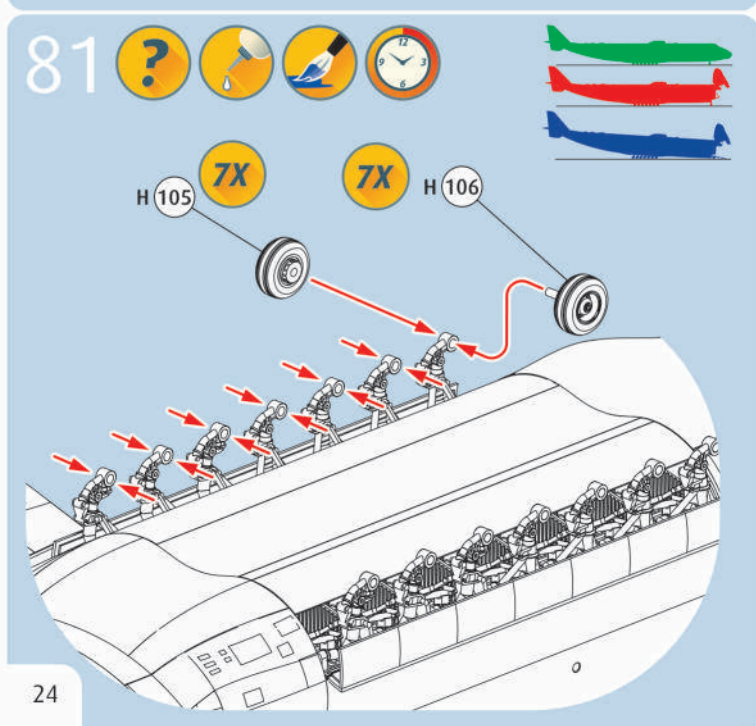
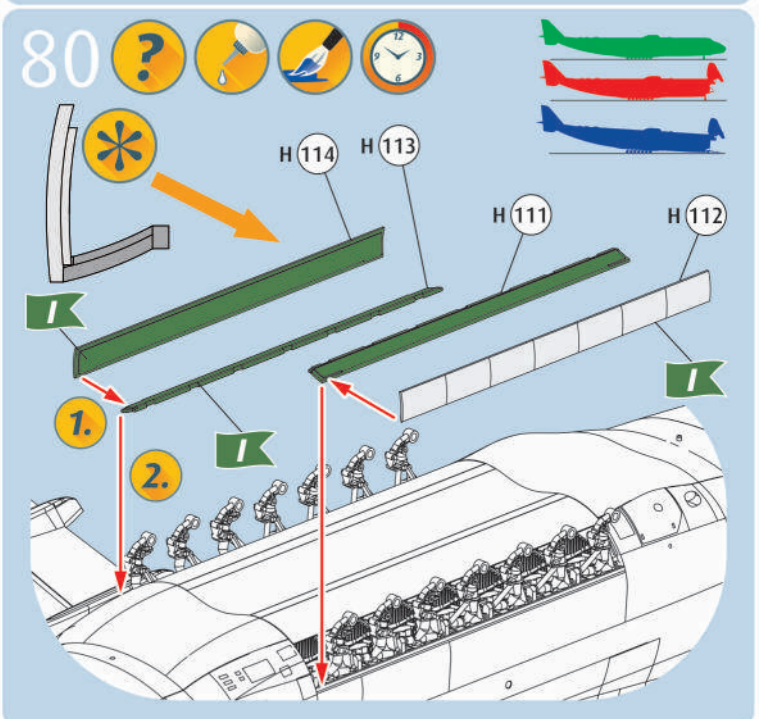
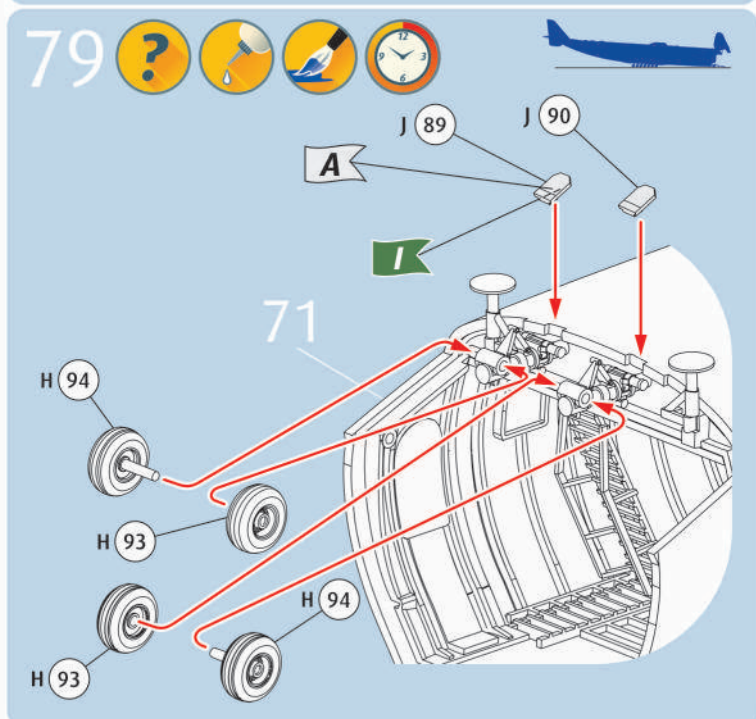
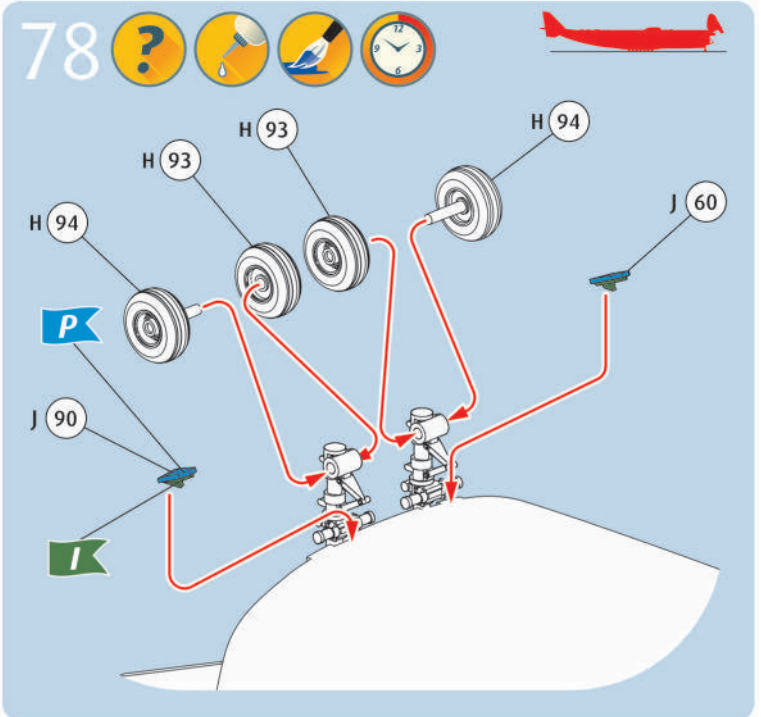
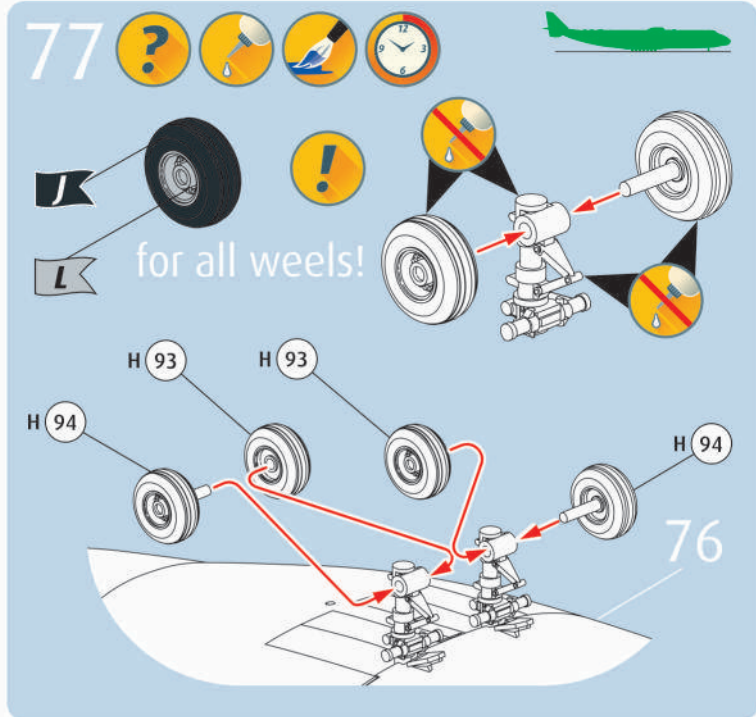

83 ? [Screwdriver icon] [Pencil icon] [Clock icon]

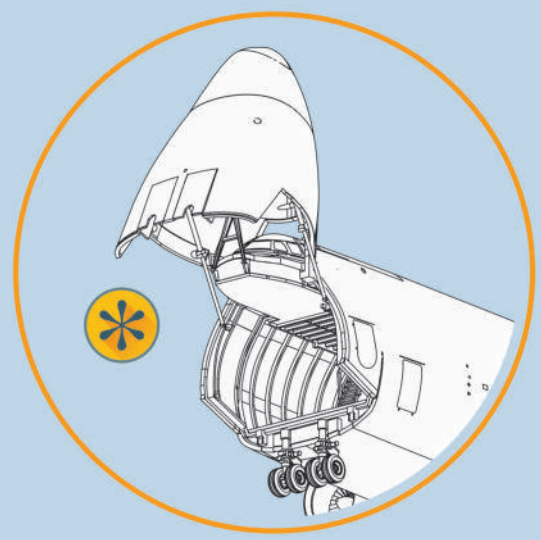
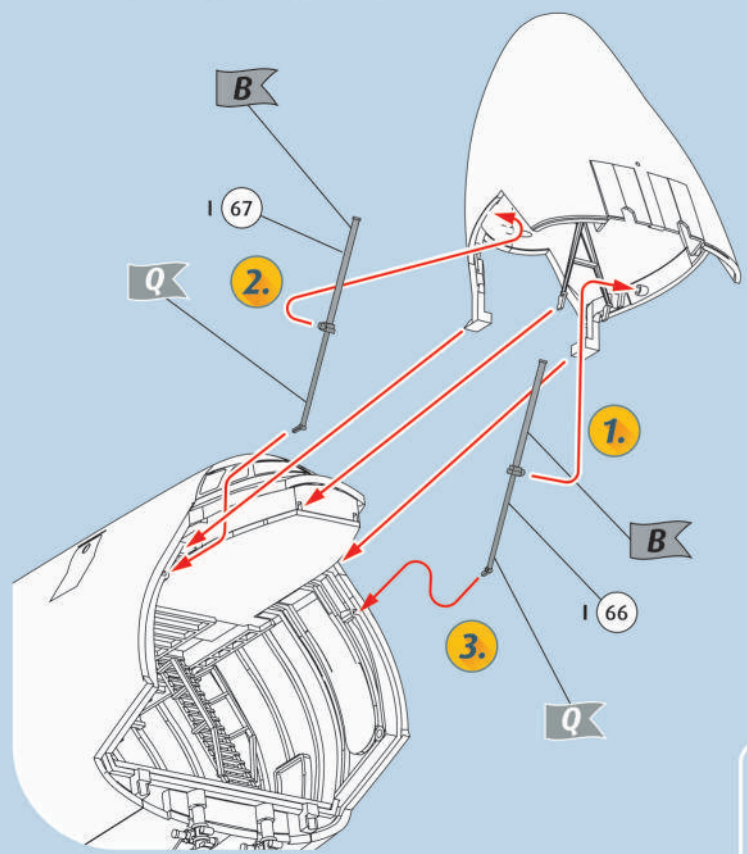
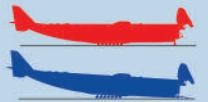

84 ? [Screwdriver icon] [Pencil icon] [Clock icon]

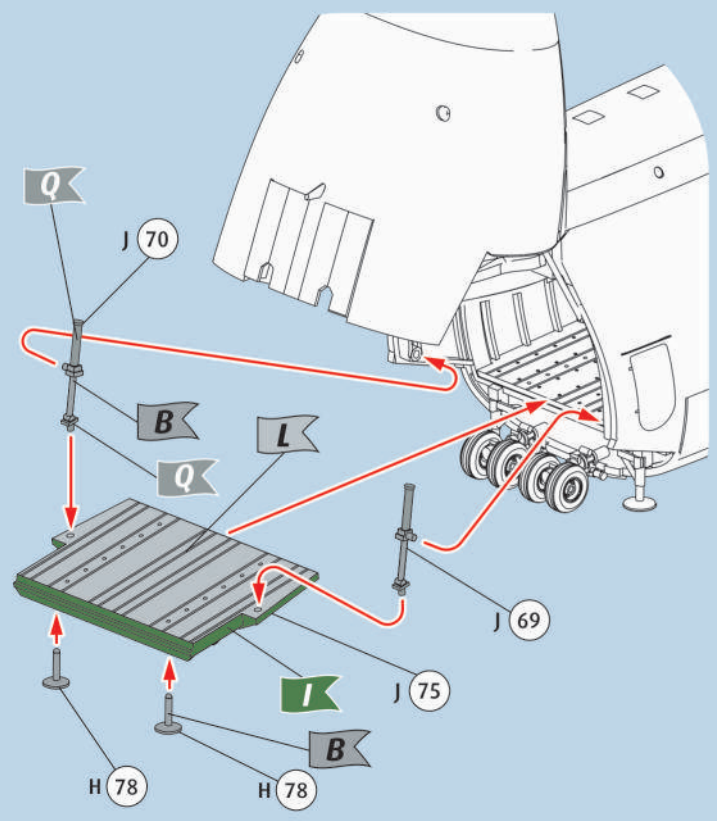

85 ? [Screwdriver icon] [Pencil icon] [Clock icon]

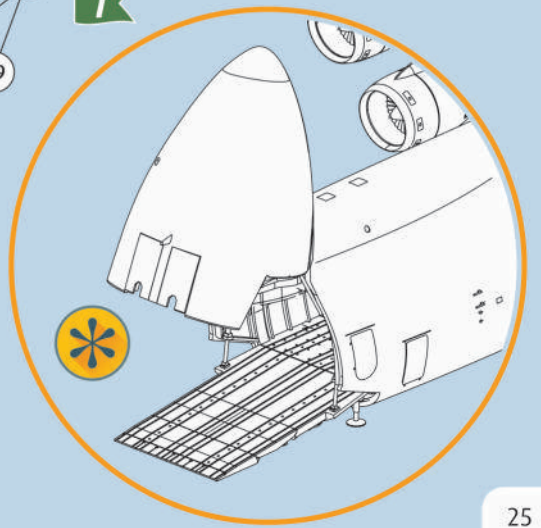
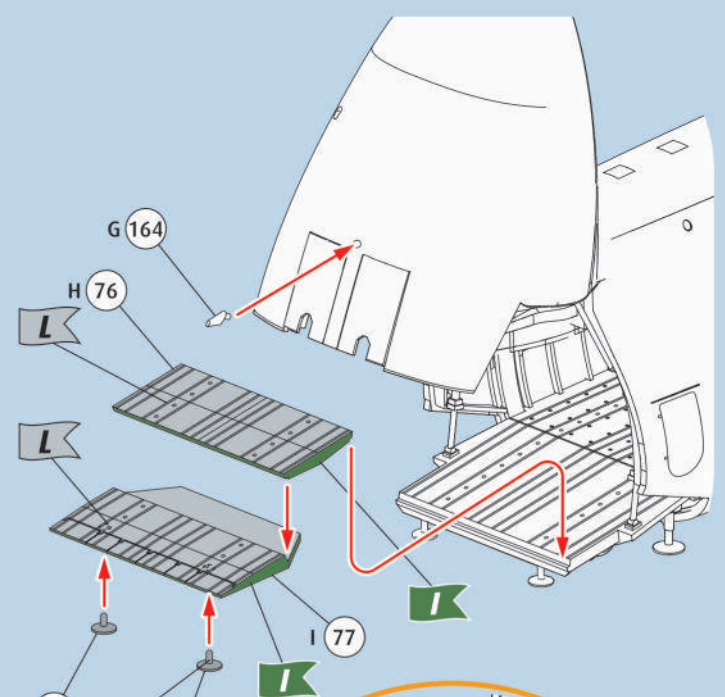

86

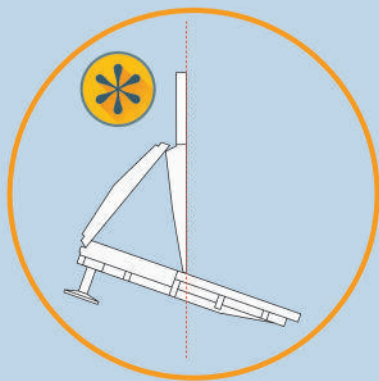
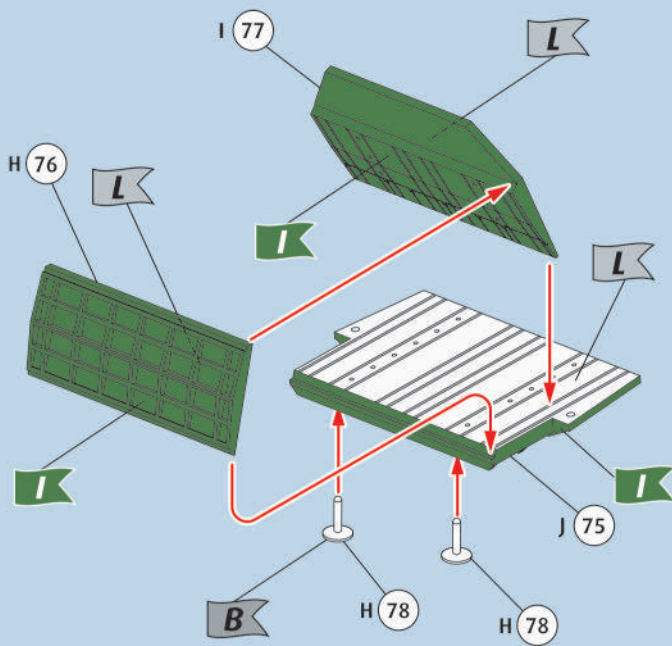

87

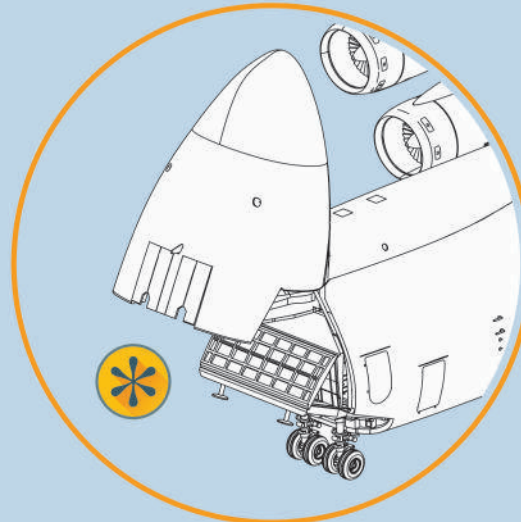
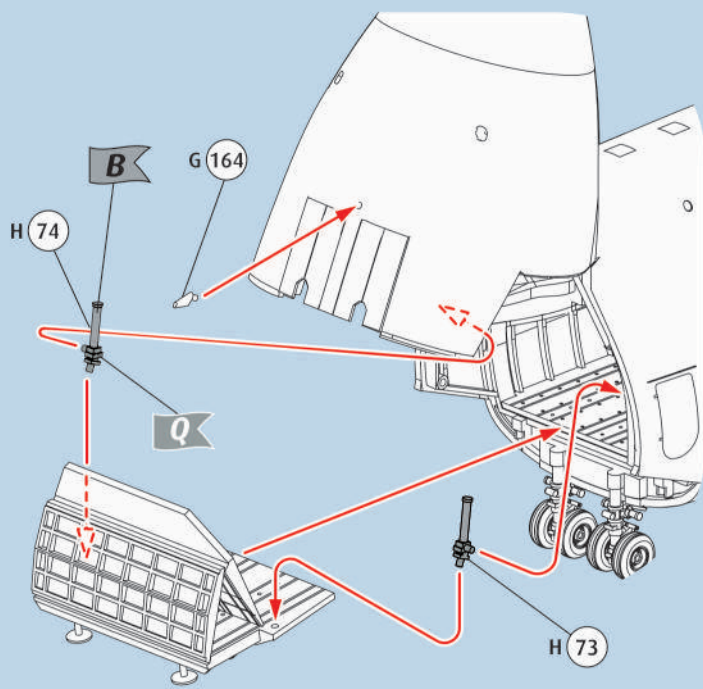

88

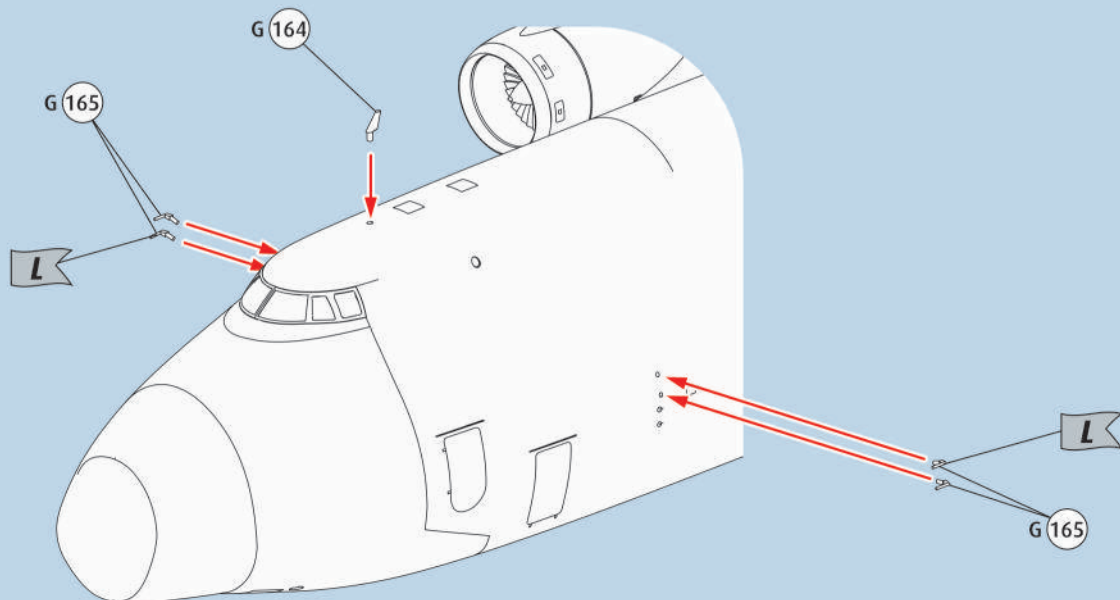

89 ?

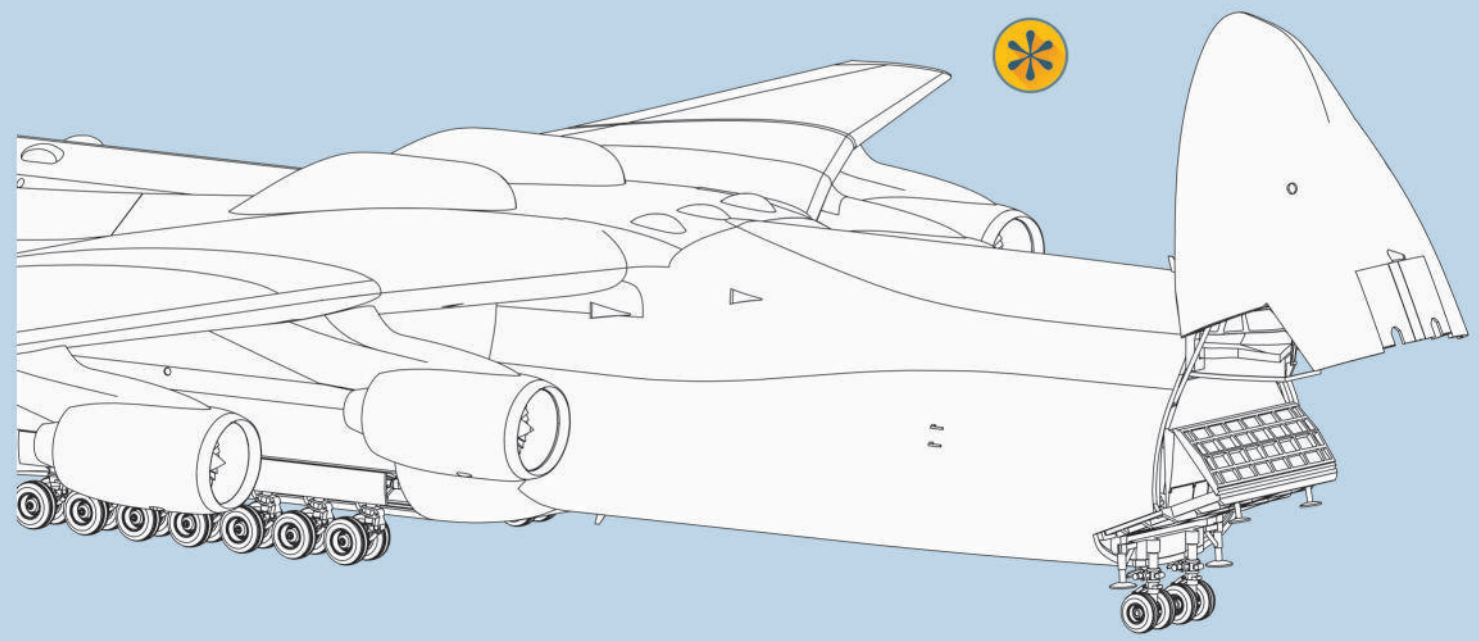

90 ?

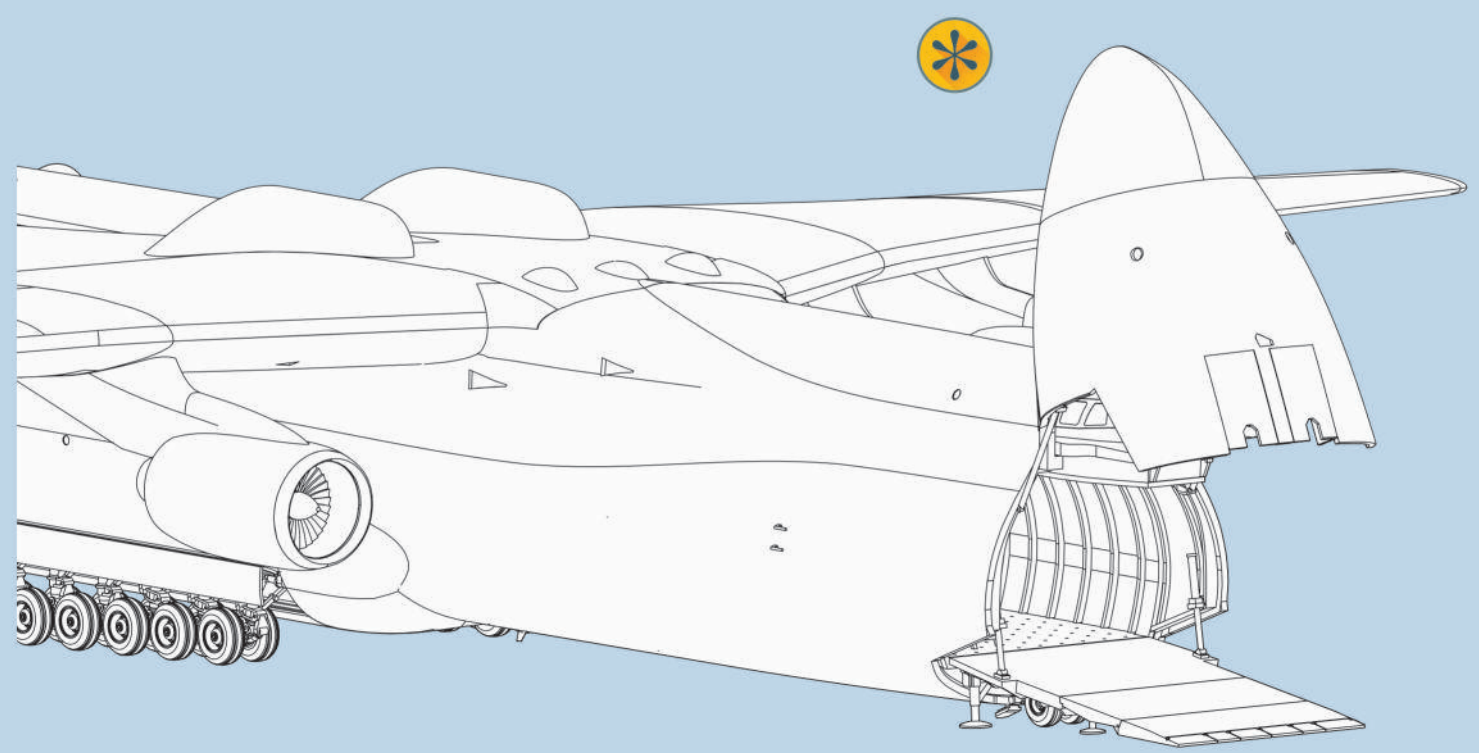

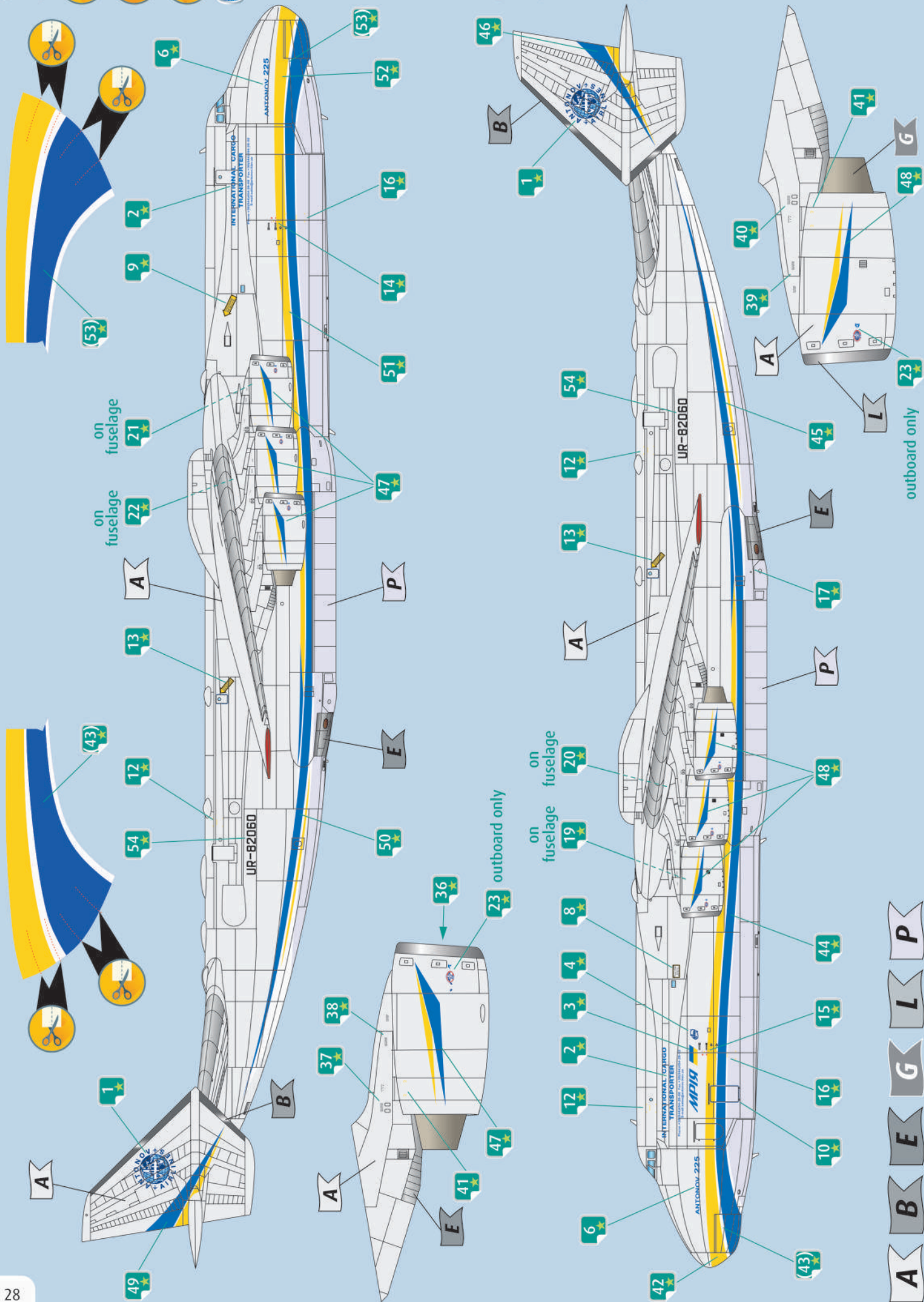



Antonov An-225 markings 09/2016 - present

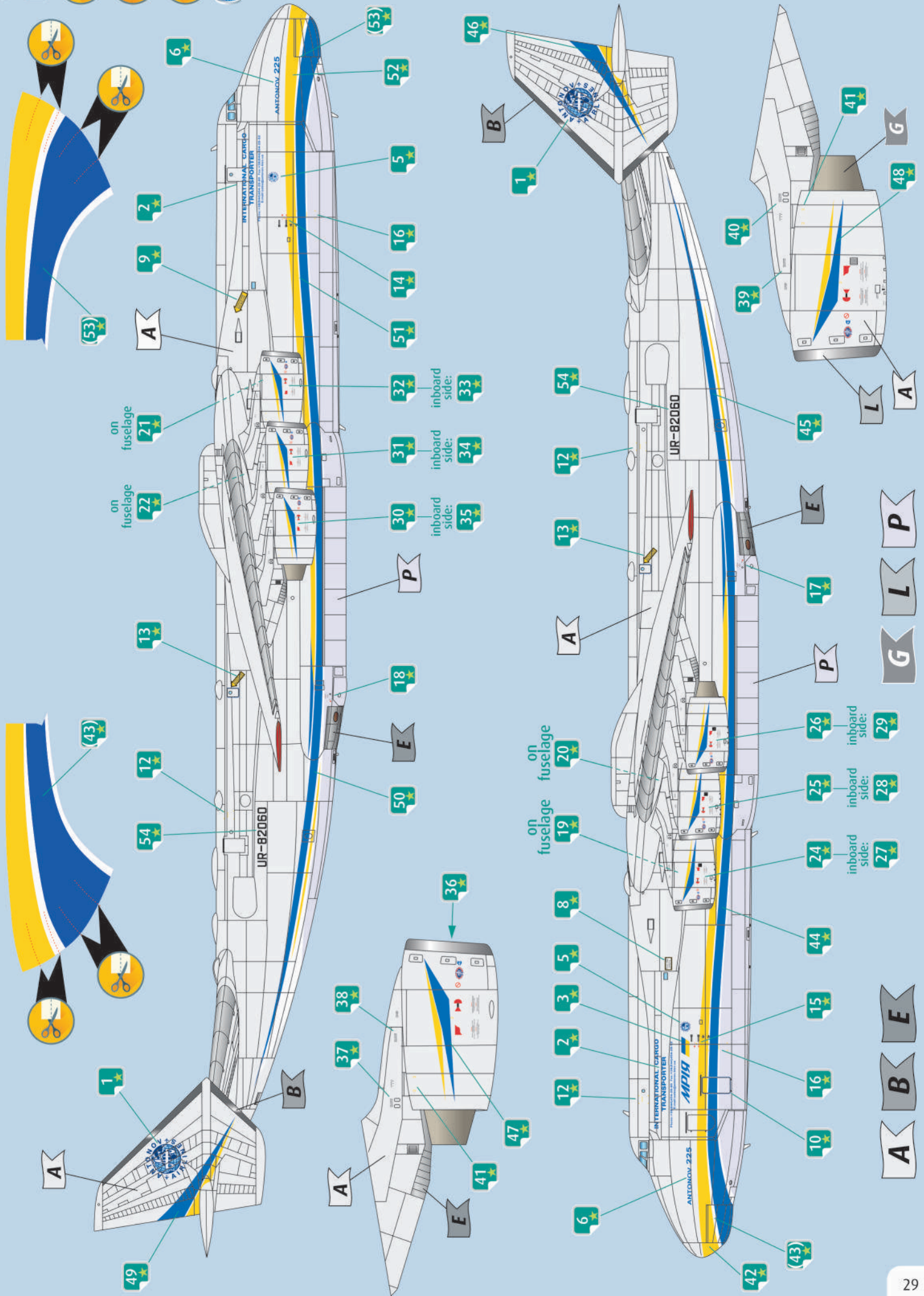

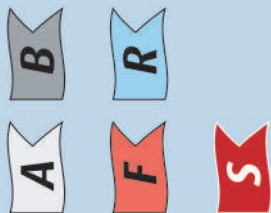



Antonov An-225

