

SPACE: 1999 EAGLE Photoetch Set

**PARA
GRAFIX™**
PGX177

ParaGrafix states that our use of the trademarked terms listed below in our product descriptions constitutes fair use and nominative use and is in no way to offer confusion that ParaGrafix and any of the following noted trademark holders are related companies, nor do we state that we are endorsed by these trademark holders. We are an AFTERMARKET company acting in GOOD FAITH in providing high quality products to loyal customers who have already purchased products related to these trademarks. ParaGrafix is actually providing these trademark holders a venue of free advertising and indirectly provide these trademark holders with more sales leads. Space: 1999 is a trademark of ITC. All Rights Reserved.

INTRODUCTION

Thank you for purchasing ParaGrafix's ...

Materials

In addition to the photoetch, you will also need scissors or a knife* to remove individual pieces from the main fret, a file to remove material left from cutting, and super glue (aka CA or cyanoacrylate). Additionally, to fold some pieces, you will need a pair of razor blades** or a specialty tool such as an Etchmate 3C from Mission Models.

* We prefer a #17 Xacto chisel blade.

** Extreme care must be taken when using razor blades. Risk of serious injury.

Raised Detail

Where applicable, these instructions note an area where the raised kit detail must be removed. This may be done in whatever way you are most comfortable: sanding, filing, chiseling. Note that in most cases the surface does not need to be perfectly smooth as the photoetched part will replace the "lost" kit detail.

Installation Parts Order

The installation steps are not in any particular order. You can complete them as you see fit to complement your kit construction order.

Key

Kit part (plastic): ①

Photoetched part: ①

Transport Pod

Remove Kit Door

After assembling the transport pod (kit parts 2 through 5) remove the raised door detail from both ends. Note that the etch piece (1) has through for the indented door panels – you will want to make sure that the kit part is smooth behind this area.

Attach End Caps

Attach the etch end pieces (1) to each end of the transport pod.

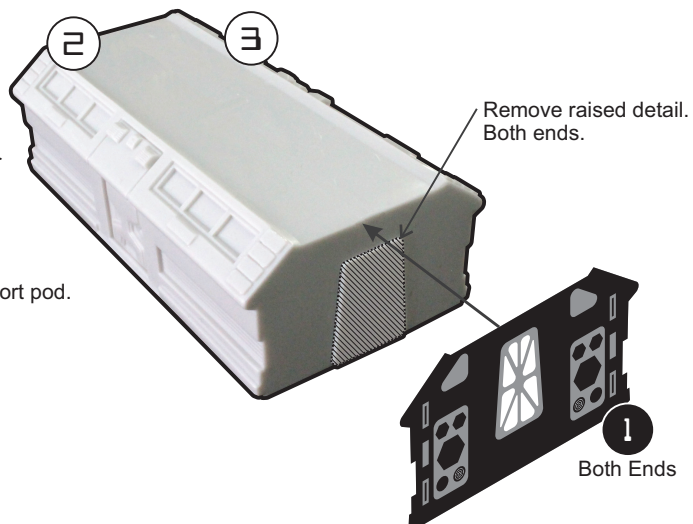

Service Modules

Remove Raised Details

Assemble the service modules (kit parts 8, 10, 11 and 6, 7, 9, 12 for the front and rear modules, respectively). Remove the raised door and control panel details – this can be done roughly as it will be covered by etch parts 2. (Make sure, though, that the plastic has no remaining raised areas.)

Attach Etch Pieces

Attach etch parts 2 over each door, centering over the raised flat area. Now attach etch parts 3 so that their outside edges match the fine line on parts 2.

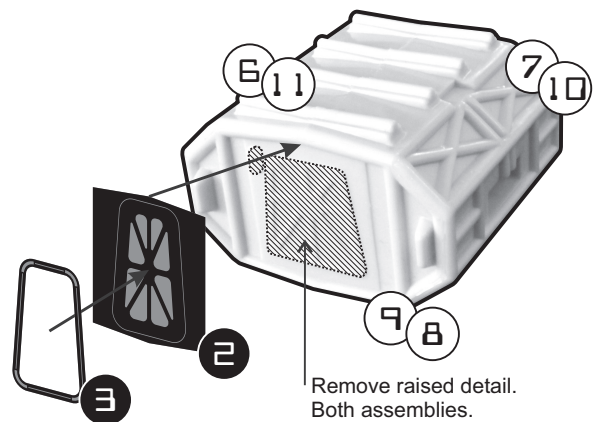

Command Module

Assemble kit parts 13 and 14.

View Screen Frames

Attach etch frames (5) to each "window" opening.

Steering Rockets

Clean out each opening and remove the raised detail for the top and bottom rockets. Attach kit parts 4 in the openings (4 places).



Rocket Diffusers

Mount each diffuser (etch part 7) to the inside of a rocket nozzle (kit # 37, 38, 39, and 40). A 7/16" long (11mm) length of 7/32" to 1/4" (5.5mm to 6.3mm) tubing can be used to space the diffuser from the edges of the nozzle.

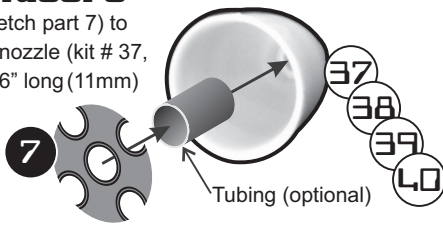

RCS Thrust Deflectors

Remove the mounting tab on each lower pod housing (16, 20, 24, 28) and attach etch part 9. RCS thrusters (18, 22, 26, 30) mount normally to center of etch 9.

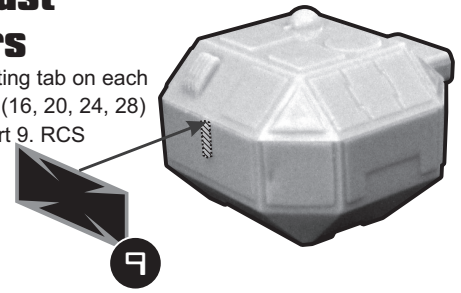

Landing Gear - Repeat 4 Times

NOTE: Tubing for assembling gear is **not included** in this photoetch set. 0.1" diameter (2.5mm) tubing is required for the main sections, and the appropriate sized nesting tube or rod is needed for the "sliding" portion. Size of the nesting tube or rod depends on the type of material and manufacturer used.

OPERATIONAL GEAR: Instructions for making spring loaded, operational gear is beyond the scope of these instructions and the method used is left to the individual builder. Note that hinge pin locations are provided on etch parts 8 and 10 for the convenience of the builder.

Pod Cage

Remove the box from the lower portion of each landing gear pod (kit parts 16, 20, 24, and 28) and mount etch parts 6 in their place. Fold etch cage (10) as shown at right and mount to part 6 so the tabs fit into the slots on 6. Note that the small extension on 10 needs to point toward the rear of the Eagle on all four pods.

TUBING: Attach a length of 0.1" diameter tubing so that it is flush with the outside edge of etch part 10 and continues through the hole in part 6. **IMPORTANT:** You will want to reinforce this section of tube as it will be holding up the weight of the kit. This can be done by adding a nesting section of tubing to the **outside** of the tube on the interior of the pods – it is also a good idea to have the two sections of tube extend so that they meet the upper piece of the pods (kit parts 15, 19, 23, and 27).

Landing Pads

Remove the frame and rod from kit landing pads (17, 21, 25 and 29). Attach etch part 14 in place on the landing pads.

Fold etch part 8 as shown and assemble with parts 11 and 14 to replace the raised detail.

TUBING: Attach a length of 0.1" diameter tubing so that it is flush with the top of etch part 8. **IMPORTANT:** You will want to reinforce this tube – a good way to do this is to wait for all glue to set/cure, then drill through the kit landing pads using a bit that matches the diameter of the mating tube/rod you will be using for the "piston" portion of the gear. This will allow for adjustment of the length later. (Do not add the piston yet.)

Final Assembly

Snip off the circular flange on the cage assembly. Glue a length of the mating rod/tubing into the rod installed in the Pod Cage Assembly – allow the glue to fully cure.

Slide the Landing Pad Assembly onto rod/tubing, making sure that the off-center hinge hole is aligned with the circular tab on the cage. The distance between the two assemblies will be determined by which scissor actuator (13 landed, 12 in-flight) you will be using – the actuator runs from the ex-location of the circular flange to the rear hinge hole on the landing pad.

After distance has been set and the pad and pod are aligned properly, apply glue to stick them together. When the glue is fully cured, remove any part of the rod extending out of the bottom of the pad.

Attach the scissor actuator to the pod cage and glue in position.

Attach to Assemblies to Kit

Attach the assemblies per the kit instructions. Remember that the scissor actuators all point toward the rear of the ship.

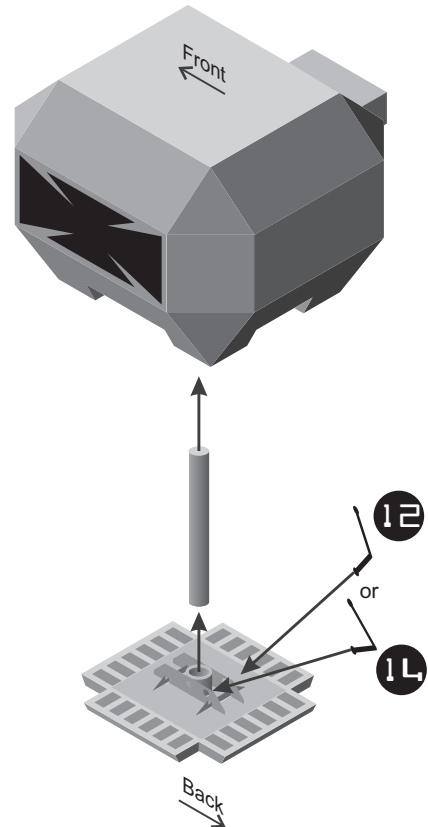
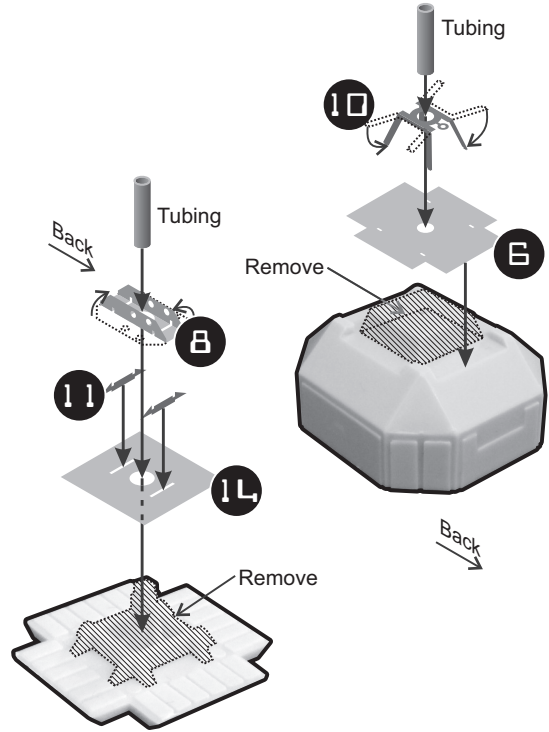

148 Rocklawn Ave.
Attleboro MA 02703 USA
+1 508-431-9800
www.ParaGrafix.biz