



03881-0379

LEVEL 4

1 2 3 4 5



Lufthansa New Livery Airbus A350-900

Beiliegenden Sicherheitstext beachten / Please note the enclosed safety advice

- Ⓢ Beiliegenden Sicherheitstext beachten und nachschlagbereit halten.
- Ⓢ Please note the enclosed safety advice and keep safe for later reference.
- Ⓢ Respecter les consignes de sécurité ci-jointes et les conserver à portée de main.
- Ⓢ Houdt u aan de bijgaande veiligheidsinstructies en hou deze steeds bij de hand.
- Ⓢ Seguire le avvertenze di sicurezza allegate e tenerle a portata di mano.
- Ⓢ Observar y siempre tener a disposición este texto de seguridad adjunto.
- Ⓢ Ter em atenção o texto de segurança anexo e guardá-lo para consulta.

- Ⓢ Overhold vedlagte sikkerhedsanvisninger og hav dem liggende i nærheden.
- Ⓢ Ha alltid vedlagt sikkerhetstekst klar til bruk.
- Ⓢ Beakta bifogad säkerhetstext och håll den i beredskap.
- Ⓢ Huomioi ja säilytä oheiset varoitukset.
- Ⓢ Соблюдать технику безопасности, сохранить инструкцию для дальнейших обращений.
- Ⓢ Przestrzegać załączonego tekstu dotyczącego bezpieczeństwa i mieć go zawsze pod ręką.
- Ⓢ Dodržujte tento příložený bezpečnostní text a mějte ho po ruce.
- Ⓢ A mellékelt biztonsági szöveget vegye figyelembe és tartsa fellapozásra készen.

- Ⓢ Respektujte příložený bezpečnostní text a uchovajte ho pre budúce použitie.
- Ⓢ Respectați textul de siguranță atașat și păstrați-l la îndemână.
- Ⓢ Спазвайте приложениа текст за безопасност и го дръжте под ръка за справки.
- Ⓢ Priliena varnostna navodila izvajajte in jih hranite na vsem dostopnem mestu.
- Ⓢ Αάβετε υπόψη σας το συννημένο κείμενο ασφαλείας και φυλάξτε το ώστε να ανατρέχετε σε αυτό όποτε χρειάζεται.
- Ⓢ Ekteki güvenlik talimatlarını dikkate alıp, bakabileceğiniz bir şekilde muafaza ediniz.

© 2019 Revell GmbH, Henschelstr. 20-30, D-32257 Bünde.

REVELL IS THE REGISTERED TRADEMARK OF REVELL GMBH, GERMANY. www.revell.de

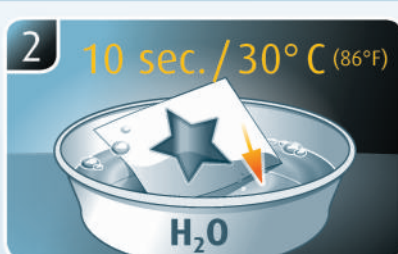
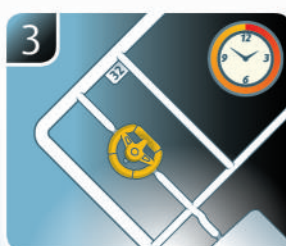
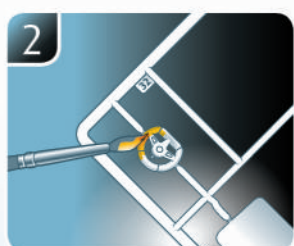
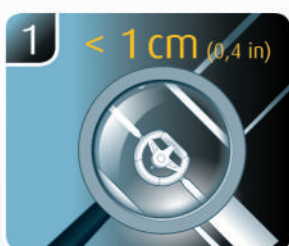
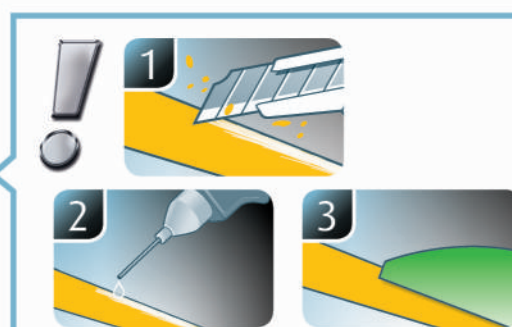
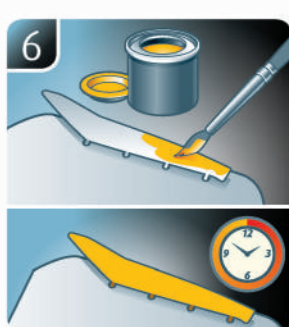
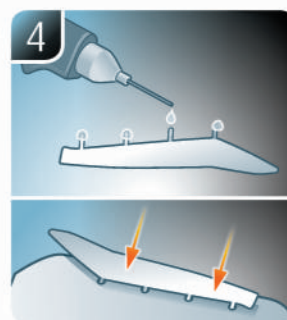
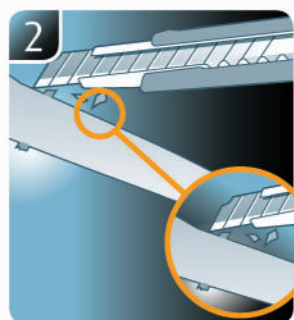
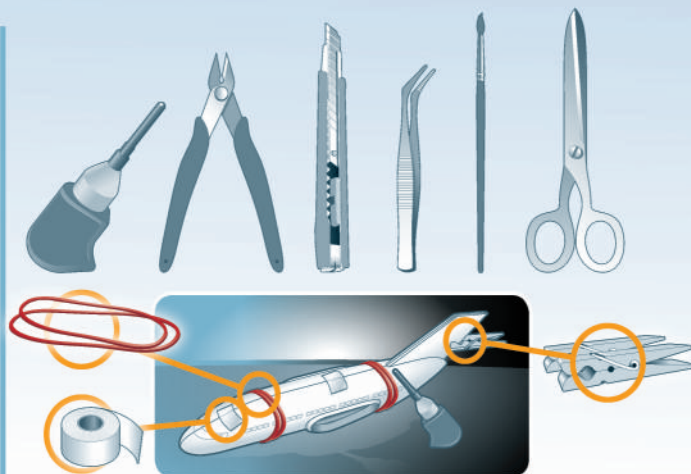

- DE Weitere Tipps und Tricks.
- AD Additional tips and tricks.
- FR Conseils et astuces supplémentaires.
- NL Andere tips en trucs.
- IT Ulteriori consigli e suggerimenti.
- ES Consejos y sugerencias adicionales.
- PT Mais dicas e truques.

- DK Flere tips og tricks.
- NO Flere tips og tricks.
- SE Ytterligare tips och tricks.
- FI Lisää vinkkejä ja niksejä.
- PL Dalsze wskazówki i sugestie.
- RU Другие советы и хитрости.
- PL Dalsze wskazówki i sugestie.
- CZ Další tipy a rady.
- HU További ötletek és fogások.
- SK Ďalšie tipy a triky.
- RO Alte sfaturi și trucuri.

- GR Други полезни съвети и трикове.
- SI Nadaljnji nasveti in zvijače.
- GR Προσθετες συμβουλές και κόλποι.
- TR Diğer öneriler ve ipuçları.

www.revell.de



- DE Kleben
- EN Glue
- FR Coller
- NL Lijmen
- IT Incollare
- ES Pegamento
- PT Colar
- CS Lim
- NO Lime
- SE Limma
- FI Liimaa
- RU Клеить
- PL Przykleić
- CZ Slepění
- HU Ragassza rá
- SK Lepiť
- SL Lipiti
- ES Zalenete
- GR Πρίλεπτε
- TR Yapıştırma



- DE Bemalen
- EN Paint
- FR Peindre
- NL Beschilderen
- IT Colorare
- ES Pintar
- PT Pintar
- CS Mal
- NO Male
- SE Måla
- FI Maalaa
- RU Раскрасить
- PL Pomalować
- CZ Pomalovat
- HU Fesse be
- SK Natrief
- SL Vopisiti
- ES Боядисайте
- GR Ροβαρβείτε
- TR Boyama



- DE Nicht kleben
- EN Don't glue
- FR Ne pas coller
- NL Niet lijmen
- IT Non incollare
- ES No pegamento
- PT Não colar
- CS Lim ikke
- NO Ikke lime
- SE Limma inte
- FI Älä liimaa
- RU Не клеить
- PL Nie przyklejać
- CZ Nelepít
- HU Ne ragassza rá
- SK Ne lepíť
- SL Nu lipiti
- ES Не лепете
- GR Μην κολλήσετε
- TR Yapıştırmayın



- DE Anzahl der Arbeitsgänge.
- EN Number of working steps.
- FR Nombre d'étapes de travail.
- NL Het aantal bouwstappen.
- IT Numero di fasi di lavoro.
- ES Número de pasos de trabajo.
- PT Número de passos de trabalho.
- CS Antal arbejdsgange.
- NO Antall arbeidstrinn.
- SE Antal operationer.
- FI Työvaiheiden määrä.
- RU Количество операций.
- PL Liczba cykli roboczych.
- CZ Počet pracovních kroků.
- HU A munkamenetek száma.
- SK Počet pracovných operácií.
- HU Numărul etapelor de lucru.
- ES Брой работни стъпки.
- GR Στέβιλο delovnih postopkov.
- TR Αριθμός εργασιών.
- TR Çalışma adımı sayısı.



- DE Zusammenbau Reihenfolge.
- EN Sequence of assembly.
- FR Ordre d'assemblage.
- NL Volgorde van montage.
- IT Sequenza di assemblaggio.
- ES Secuencia de montaje.
- PT Sequência de montagem.
- CS Samlerækkefølge.
- NO Monteringsrekkefølge.
- SE Montering ordningsföljd.
- FI Kokoamisjärjestys.
- RU Последовательность сборки.
- PL Kolejność montażu.
- CZ Pořadí složení.
- HU Összerakási sorrend.
- SK Poradie zostavenia.
- HU Ordinea asamblării.
- ES Последователност на сглобяване.
- GR Υρστν red sestavljanja.
- TR Σειρά τοποθέτησης.
- TR Parçaları birleştirme sırası.



- DE Wahlweise
- EN Optional
- FR Facultatif
- NL Naar keuze
- IT Facoltativamente
- ES Opcional
- PT Opcional
- CS Valgfri
- NO Valgfritt
- SE Valfri
- FI Valinnaisesti
- RU На выбор
- PL Opcjonalnie
- CZ Volitelně
- HU Választás szerint
- SK Alternatívne
- SL Opcionál
- ES По избор
- GR Ιζβίρν
- TR Opsiyonel



- DE Bauteile trocknen lassen.
- EN Allow the parts to dry.
- FR Laisser sécher les pièces.
- NL Onderdelen laten drogen.
- IT Lasciare asciugare i componenti.
- ES Dejar secar las piezas.
- PT Deixar as peças secar.
- CS Lad delene tørre.
- NO Tørk komponenter.
- SE Låt komponenterna torka.
- FI Anna rakenneosien kuivua.
- RU Дайте деталям высохнуть.
- PL Pozostawić elementy konstrukcji do wyschnięcia.
- CZ Nechte díly uschnout.
- HU Hagyja megszáradni az alkatrészeket.
- SK Konštrukčné diely nechajte vyschnúť.
- HU Lásajti componentele szá se usuce.
- ES Oставете сглобените части да изсъхнат.
- SL Osušite sestavne dele.
- ES Αφήστε τα μέρη να στεγνώσουν.
- TR Yapı parçalarını kurumaya bırakın.



- DE Abbildung zusammengesetzter Teile.
- EN Illustration of assembled parts.
- FR Figure représentant les pièces assemblées.
- NL Afbeelding van samengevoegde onderdelen.
- IT Foto delle parti assemblate.
- ES Figura de las piezas montadas.
- PT Ilustração das peças montadas.
- CS Ilustration af samlede dele.
- NO Figur av sammensatte deler.
- SE Bild på sammansatta detaljer.
- FI Kootujen osien kuva.
- RU Изображение смонтированных деталей.
- PL Rysunek połączonych części.
- CZ Zobrazení spojených dílů.
- HU Összerakott alkatrészek ábrája.
- SK Obrázok dielov, ktoré sa majú zmontovať.
- HU Figura reprezentând piesele asamblate.
- ES Изображение на сглобените части.
- SL Slika sestavljenih delov.
- ES Απεικόνιση των τοποθετημένων μερών.
- TR Birleştirilmiş parçaları resmi.



- DE Gleichen Vorgang auf der gegenüberliegenden Seite wiederholen.
- EN Repeat same procedure on opposite side.
- FR Opérer de la même façon sur l'autre face.
- NL Dezelfde handeling herhalen aan de tegenoverliggende kant.
- IT Ripetere il procedimento dall'altra parte.
- ES Repetir el mismo procedimiento en el lado contrario.
- PT Repetir alguns procedimentos no lado oposto.
- CS Gentag proceduren på den modsatte side.
- NO Gjenta samme forløp på motliggende side.
- SE Upprepa samma process på motsatta sidan.
- FI Toista menettelyä vastakkaisella puolella.
- RU Повторить такие же действия на противоположной стороне.
- PL Powtórzyc te same czynności po przeciwnej stronie.
- CZ Stejný postup opakujte na protilehlé straně.
- HU Ismételj meg a műveletet az ellentétes oldalon.
- SK Rovnaký postup zopakujte na protiahlj strane.
- HU Repetajti același procedeu pe latura opusă.
- ES Повторете същите стъпки на срещуположната страна.
- SL Enak postopek ponovite na nasprotni strani.
- ES Επαναλάβετε την ίδια διαδικασία στην αντίθετη πλευρά.
- TR Aynı işlem adımlarını diğer tarafta da uygulayın.



- DE Zur besseren Ausbalancierung mit einem Gewicht beschweren.
- EN Add weight for improved stability.
- FR Pour une mise en place correcte allourdir.
- NL Voor evenwicht gewicht aanbrengen.
- IT Aggiungere un peso per migliorare la stabilità.
- ES Añadir peso para una mayor estabilidad.
- PT Para melhor estabilidade colocar um peso.
- CS Tilføi vægt for at forbedre stabiliteten.
- NO Legg til vekt for en bedre stabilitet.
- SE Belasta med en vikt för bättre balansering.
- FI Painota painolla parempaa tasapainottamista varten.
- RU Для лучшей балансировки утяжелить грузом.
- PL Aby zapewnić równowagę, obciążyc ciężarkiem.
- CZ Pro lepší vyvážení zatěžte závažím.
- HU A jobb kiegyensúlyozás érdekében használjon súlynehezéket.
- SK Pre lepšie vyváženie zatažte závažím.
- HU Aplicajti o greutate pentru o mai bună stabilitate.
- ES За по-добър баланс поставете тежест.
- SL Za boljše izravnavo obtežite z utežjo.
- ES Προσθέστε βάρo για καλύτερη σταθερότητα.
- TR Daha iyi bir dengeleme için ağırlık yerleştirin.



- DE Loch bohren.
- EN Make a hole.
- FR Faire un trou.
- NL Maak een gat.
- IT Praticare un foro.
- ES Hacer un agujero.
- PT Fazer um furo.
- CS Lav et hul.
- NO Bor et hull.
- SE Borra hål.
- FI Poraa reikä.
- RU Просверлить отверстие.
- PL Wywiercić otwór.
- CZ Vyvrteť otvor.
- HU Fúrjon lyukat.
- SK Vyvrťajte otvor.
- HU Faceti o gaură.
- ES Пробийте дупка.
- SL Izvrtajte izvrtino.
- ES Ανοίξτε το άνοιγμα.
- TR Delik açın.



- DE Mit einem Messer abtrennen.
- EN Detach with knife.
- FR Détacher au couteau.
- NL Met een mesje afsnijden.
- IT Separare con un coltello.
- ES Separar con cuchillo.
- PT Separar com uma faca.
- CS Skær af med en kniv.
- NO Skær af med en kniv.
- SE Skall skiljas av med en kniv.
- FI Erota veitsellä.
- RU Отделить ножом.
- PL Oddzielić za pomocą noża.
- CZ Oddělte nožem.
- HU Válassza le késsel.
- SK Oddelte nožom.
- HU Desprindeți cu un cuțit.
- ES Откъснете с нож.
- SL Odrežite z ustreznim rezilom.
- ES Αφαιρέστε με ένα μαχαίρι.
- TR Bir bıçak ile kesin.



- DE Klarsichtteile
- EN Clear parts
- FR Pièces transparentes
- NL Transparente onderdelen
- IT Parti trasparenti
- ES Piezas transparentes
- PT Peças transparentes
- CS Klare deler
- NO Klare deler
- SE Genomskinliga detaljer
- FI Läpinäkyvät osat
- RU Прозрачные детали
- PL Przejroczyste części
- CZ Průhledné díly
- HU Átlátszó alkatrészek
- SK Číre diely
- HU Piese transparente
- ES Прозрачни части
- SL Prozorni deli
- ES Διαφανή μέρη
- TR Şeffaf parçalar



- DE Bauanleitung sorgfältig lesen.
- EN Read the assembly instructions carefully.
- FR Lisez attentivement les instructions de montage.
- NL Bouwstructies zorgvuldig doorlezen.
- IT Leggere attentamente le istruzioni per il montaggio.
- ES Lea cuidadosamente las instrucciones de montaje.
- PT Leia atentamente as instruções de montagem.
- CS Les byggevejledningen omhyggeligt.
- NO Les byggeanvisningen nøye.
- SE Monteringsinstruktionerna skall läsas noggrant.
- FI Lue kokoamisohje huolellisesti.
- RU Внимательно прочитайте инструкцию по сборке.
- PL Dokładnie przeczytać instrukcję montażu.
- CZ Přečtěte si pečlivě návod k obsluze.
- HU Figyelmesen olvassa el a szerelési útmutatót.
- SK Návod na montáž starostlivo prečítajte.
- HU Cititi cu atenție instrucțiunile de montare.
- ES Прочетете внимателно упътването за монтаж.
- SL Skrbno preberite navodila za sestavo.
- ES Διαβάστε προσεκτικά τις οδηγίες κατασκευής.
- TR Yapı kılavuzunu dikkatle okuyun.



- DE Mit Klebeband fixieren.
- EN Attach with adhesive tape.
- FR Fixer à l'aide de ruban adhésif.
- NL Met plakband vastzetten.
- IT Fissare con nastro adesivo.
- ES Fijar con cinta adhesiva.
- PT Fixar com fita adesiva.
- CS Fastgør med tape.
- NO Fest med tape.
- SE Fixera med tejp.
- FI Kiinnitä liimanauhalla.
- RU Зафиксировать липкой лентой.
- PL Przykleić taśmą klejącą.
- CZ Připevněte lepicí páskou.
- HU Rögzítse ragasztószalaggal.
- SK Fixujte lepiacou páskou.
- HU Fixajti cu bandă adezivă.
- ES Фиксирайте с тиксо.
- SL Prištrdite z lepilnim trakom.
- ES Στερεώστε κολλητική ταινία.
- TR Yapıştırma bandı ile sabitleyin.



- DE Abziehbild in Wasser einweichen und anbringen.
- EN Soak and apply decals.
- FR Mouiller et appliquer les décalcomanies.
- NL Transfer in water even laten weken en aanbrengen.
- IT Immergere la decalcomania nell'acqua e applicarla.
- ES Mojar y aplicar calcomanías.
- PT Amolecer o decalque em água e aplicar.
- CS Gør overførselsbilledet vådt og sæt det på.
- NO Myk opp avtrekkingsbildet i vann og sett på.
- SE Blötlägg dekalen i vatten och sätt på den.
- FI Pehmitä siirtokuvaa vedessä ja siirrä paikalleen.
- RU Опустите переводную картинку в воду и нанесите её.
- PL Namoczyć kalkomanie w wodzie i przykleić.
- CZ Nechte obitisk odmočit ve vodě a přilepte.
- HU Merítse vízbe és helyezze fel a matricát.
- SK Oblačkový obrázok namočte do vody a priložte na plochu.
- HU Inmuijati abjibildul în apă și aplicați-l.
- ES Потопете ваденката във вода и я поставете.
- SL Prelepnico namakajte v vodi. In namesistite.
- ES Μουσκεύετε με νερό και τοποθετείτε τις χαλκομανίες.
- TR Çıkartmayı suda yumuşatın ve takın.



- DE Zur Anbringung der Abziehbilder empfohlen.
- GB Recommended for affixing the decals.
- FR Recommandé pour l'application des décalcomanies.
- NL Aanbevolen voor het aanbrengen van de transfers.
- IT Raccomandato per l'applicazione delle decalcomanie.
- ES Recomendado para fijar bien las calcomanías.
- PT Recomendado para a fixação dos autocolantes.
- DK Anbefales til anbringelse af overførsbillederne.
- NO Anbefales til å feste avtrekksbilder.
- SE Rekommenderad för montering av klisterdekaler.
- FI Suositellaan siirtokuvien siirtämiseen.
- RU Рекомендуется для нанесения переводных картинок.
- PL Zalecane do przyklejenia kalkomanii.
- CZ Doporučujeme k umístění obtiskovacích obrázků.
- HU A matrica felhelyezéséhez ajánlható.
- SK Odporúča sa pre umiestnenie obtiskovacích obrázků.
- RO Recomandat pentru aplicarea abtildurilor.
- SR Препорчува се за поставяне на воденки.
- SI Pri nameščanju nalepnic priporočamo.
- GR Συνιστάται για την τοποθέτηση των χαλκομανιών.
- TR Çikartmaların takılması için önerilir.



- DE Zur Anbringung der Klarteile empfohlen.
- GB Recommended to fix clear parts.
- FR Recommandé pour fixer les pièces transparentes.
- NL Aanbevolen voor het aanbrengen van transparante delen.
- IT Raccomandato per l'applicazione delle parti trasparenti.
- ES Recomendado para fijar las piezas transparentes.
- PT Recomendado para a aplicação das peças transparentes.
- DK Anbefales til anbringelse af de klare dele.
- NO Anbefales til å feste klare deler.
- SE Rekommenderad för montering av de genomskinliga detaljerna.
- FI Suositellaan läpinäkyvien osien siirtämiseen.
- RU Рекомендуется для крепления прозрачных деталей.
- PL Zalecane do przyklejenia przezroczystych części.
- CZ Doporučujeme k umístění průhledných dílů.
- HU Az átlátszó darabok felhelyezéséhez ajánlható.
- SK Odporúča sa pre umiestnenie čírych dielov.
- RO Recomandat pentru aplicarea pieselor transparente.
- SR Препорчува се за поставяне на прозрачни части.
- SI Pri nameščanju prozornih delov priporočamo.
- GR Συνιστάται για την τοποθέτηση των διαφανών μερών.
- TR Şeffaf parçaların takılması için önerilir.



- DE Nicht enthalten
- GB Not included
- FR Non fourni
- NL Behoort niet tot de levering
- IT Non incluso
- ES No incluido
- PT Não incluído
- DK Medfølger ikke
- NO Ikke inkludert
- SE Ingår ej
- FI Ei sisällä
- RU Не содержится
- PL Nie wchodzi w zakres dostawy
- CZ Není obsaženo
- HU Nem tartalmazza
- SK Neobsahuje
- RO Nu este inclus
- SR Не се uključува в комплекта
- SI Ni priloženo
- GR Δεν περιλαμβάνεται
- TR İçerilmiyor

Benötigte Farben / Required colours

- FR Peintures nécessaires
- NL Benodigde kleuren
- IT Colori necessari
- ES Colores necesarios
- PT Cores necessárias
- DK Nødvendige farver
- NO Nødvendige farger
- SE Erforderliga färger
- FI Tarvittavat värit
- RU Необходимые краски
- PL Potrzebne kolory
- CZ Potřebné barvy
- HU Szükséges színek
- SK Požadované farby
- RO Culori necesare
- SR Неодходими цветове
- SI Potrebne barve
- GR Απαιτούμενα χρώματα
- TR Gerekli renkler

04

A

- DE Weiß glänzend
- GB White gloss
- FR Blanc brillant
- NL Wit glanzend
- IT Bianco lucido
- ES Blanco brillante
- PT Branco brilhante
- DK Hvid blank
- NO Hvit glansende
- SE Vit blank
- FI Valkoinen kiiltävä
- RU Белый гляцевый
- PL Biały błyszczący
- CZ Bílá lesklý
- HU Fehér, fényes
- SK Biela lesklý
- RO Alb strălucitor
- SR Бјело гланцово
- SI Bela sijoča
- GR Ασπρο γυαλιστερό
- TR Beyaz parlak

90

B

- DE Silber metallic
- GB Silver metallic
- FR Argent métallique
- NL Zilver metallic
- IT Argento metallico
- ES Plata metálico
- PT Prata metálico
- DK Sølv metallisk
- NO Sølv metallic
- SE Silver metallic
- FI Hopea metallinen
- RU Серебрянный металл
- PL Biały metaliczny
- CZ Stříbrná metalizový
- HU Ezüstmetál
- SK Strieborná metaliza
- RO Argintiu metalic
- SR Сребро металик
- SI Srebrna kovinska
- GR Ασμη μεταλλικό
- TR Gümüş rengi metalik

91

C

- DE Eisen metallic
- GB Iron metallic
- FR Fer métallique
- NL IJzer metallic
- IT Ferro metallico
- ES Acero metálico
- PT Aço metálico
- DK Stål metallisk
- NO Jern metallic
- SE Stål metallic
- FI Teräs metallinen
- RU Сталь металл
- PL Grafit metaliczny
- CZ Ocelová metalizový
- HU Acélmetál
- SK Ocelová metaliza
- RO Fier metalic
- SR Жельазо металик
- SI Železna kovinska
- GR Χρώμα σιδήρου μεταλλικό
- TR Metalik metalik

99

D

- DE Aluminium metallic
- GB Aluminium metallic
- FR Aluminium métallique
- NL Aluminium metallic
- IT Alluminio metallico
- ES Aluminio metálico
- PT Alumínio metálico
- DK Aluminium metallisk
- NO Aluminium metallic
- SE Aluminium metallic
- FI Alumiini metallinen
- RU АЛЮМИНИЙ МЕТАЛЛИК
- PL Aluminium metaliczny
- CZ Hliníková metalizový
- HU Alumínium metal
- SK Hliníková metaliza
- RO Aluminiu metalic
- SR АЛУМИНИЈ МЕТАЛИК
- SI Aluminijasta kovinska
- GR Αλουμίνιο μεταλλικό
- TR Aluminiumu grisi metalik

70%

91

E

83

30%

- DE Eisen metallic
- GB Iron metallic
- FR Fer métallique
- NL IJzer metallic
- IT Ferro metallico
- ES Acero metálico
- PT Aço metálico
- DK Stål metallisk
- NO Jern metallic
- SE Stål metallic
- FI Teräs metallinen
- RU Сталь металл
- PL Grafit metaliczny
- CZ Ocelová metalizový
- HU Acélmetál
- SK Ocelová metaliza
- RO Fier metalic
- SR Жельазо металик
- SI Železna kovinska
- GR Χρώμα σιδήρου μεταλλικό
- TR Metalik metalik

+

- DE Rost matt
- GB Rust matt
- FR Rouille mat
- NL Roest mat
- IT Ruggine opaco
- ES óxido mate
- PT Ferrugem mate
- DK Rust mat
- NO Rust matt
- SE Rost matt
- FI Ruoste matta
- RU Ржавый матовый
- PL Rdzawy matowy
- CZ Rezavá matný
- HU Rozszaszínú, fénytelen
- SK Hrdzavá matný
- RO Ruginiu mat
- SR Ръжда матово
- SI Rjasta mat
- GR Χρώμα σκουριας ματ
- TR Pas rengi mat

90%

54

F

07

10%

- DE Nachtblau glänzend
- GB Midnight blue gloss
- FR Bleu nuit brillant
- NL Nachtblauw glanzend
- IT Blu notte lucido
- ES Azul noche brillante
- PT Azul noite brilhante
- DK Midnatsblå blank
- NO Nattblå glansende
- SE Midnattsblå blank
- FI Yönsininen kiiltävä
- RU Синяя ночь гляцевый
- PL Granatowy błyszczący
- CZ Noční modrá lesklý
- HU Éjkék, fényes
- SK Nočná modrá lesklý
- RO Albastru-inchis strălucitor
- GR Νοχνοσινίο γλάνцовο
- SI Nočno-modra sijoča
- GR Μπλε της νύχτας γυαλιστερό
- TR Gece mavisi parlak

+

- DE Schwarz glänzend
- GB Black gloss
- FR Noir brillant
- NL Zwart glanzend
- IT Nero lucido
- ES Negro brillante
- PT Preto brilhante
- DK Sort blank
- NO Sort glansende
- SE Svart blank
- FI Musta kiiltävä
- RU Чёрный гляцевый
- PL Czarny błyszczący
- CZ Černá lesklý
- HU Fekete, fényes
- SK Čierna lesklý
- RO Negru-strălucitor
- GR Черно гланцовο
- SI Črna sijoča
- GR Μαύρο γυαλιστερό
- TR Siyah parlak

09

H

- DE Anthrazit matt
- GB Anthracite matt
- FR Anthracite mat
- NL Antraciet mat
- IT Antracite opaco
- ES Antracita mate
- PT Antracite mate
- DK Antracitgrå mat
- NO Antrasitt matt
- SE Antracitgrå matt
- F Antrasiitinharmaa matta
- RU Антрацит матовый
- PL Antracyt matowy
- CZ Antracitová šedá matný
- HU Antracit, fénytelen
- SK Čierna uhľová matný
- NO Antracit mat
- BG Антрацит матово
- SI Antracit mat
- GR Γκρι ανθρακί ματ
- TR Anthrazit mat

330

I

- DE Feuerrot seidenmatt
- GB Fiery red silk matt
- FR Rouge feu satiné mat
- NL Vuurood zijdemat
- IT Rosso fuoco opaco satinato
- ES Rojo fuego mate satinado
- PT Vermelho fogo mate sedoso
- DK Ildrød silkematt
- NO Ildrød silkematt
- SE Eldröd sidenmatt
- F Tulenpunainen silkkimatta
- RU Огненно-красный шелковисто-матовый
- PL Ognistoczerwony jedwabście matowy
- CZ Ohnivě červená jemně matný
- HU Tűzpiros, fakóselymes
- SK Ohnivá červená hodvábné matný
- NO Roşu aprins satinat
- BG Огненочервено коприненоматово
- SI Ognjeno-rdeča svilenlo-mat
- GR Κόκκινο φωτιάς σατινέ
- TR Alev kırmızısı ipeksi mat

76

J

- DE Hellgrau matt
- GB Light grey matt
- FR Gris clair mat
- NL Lichtgrijs mat
- IT Grigio chiaro opaco
- ES Gris claro mate
- PT Cinza claro mate
- DK Lysegrå mat
- NO Lysegrå matt
- SE Ljusgrå matt
- F Vaaleanharmaa matta
- RU Светло-серый матовый
- PL Jasnoszary matowy
- CZ Světlá šedivá matný
- HU Világosszürke, fénytelen
- SK Svetlo sivá matný
- NO Gri-deschis mat
- BG Светлосиво матово
- SI Svetlo-siva mat
- GR Γκρι ανοιχτό ματ
- TR Açık gri mat

364

K

- DE Laubgrün seidenmatt
- GB Leaf green silk matt
- FR Vert feuillage satiné mat
- NL Loofgroen zijdemat
- IT Verde foglia opaco satinato
- ES Verde hoja mate satinado
- PT Verde folha mate sedoso
- DK Løvgrøn silkematt
- NO Løvgrønn silkematt
- SE Skogsgrön sidenmatt
- F Lehdenvihreä silkkimatta
- RU Зелёная листва шелковисто-матовый
- PL Zielony w odcieniu liści jedwabście matowy
- CZ Listová zeleň jemně matný
- HU Lombzöld, fakóselymes
- SK Listová zelená hodvábné matný
- NO Verde-frunzå satinat
- BG Зелена шума коприненоматово
- SI Listnato-zelena svilenlo-mat
- GR Πράσινο σατινέ
- TR Yaprak yeşili ipeksi mat

57

M

- DE Grau matt
- GB Grey matt
- FR Gris mat
- NL Grijs mat
- IT Grigio opaco
- ES Gris mate
- PT Cinzento mate
- DK Grå mat
- NO Grå matt
- SE Grå matt
- F Harmaa matta
- RU Серый матовый
- PL Szary matowy
- CZ Šedá matný
- HU Szürke, fénytelen
- SK Sivá matný
- NO Gri mat
- BG Сиво матово
- SI Siva mat
- GR Γκρι ματ
- TR Gri mat

371

N

- DE Hellgrau seidenmatt
- GB Light grey silk matt
- FR Gris clair satiné mat
- NL Lichtgrijs zijdemat
- IT Grigio chiaro opaco satinato
- ES Gris claro mate satinado
- PT Cinza claro mate sedoso
- DK Lysegrå silkematt
- NO Lysgrå silkematt
- SE Ljusgrå sidenmatt
- F Vaaleanharmaa silkkimatta
- RU Светло-серый шелковисто-матовый
- PL Jasnoszary jedwabście matowy
- CZ Světlá šedá jemně matný
- HU Világosszürke, fakóselymes
- SK Svetlo sivá hodvábné matný
- NO Gri-deschis satinat
- BG Светлосиво коприненоматово
- SI Svetlo-siva svilenlo-mat
- GR Γκρι ανοιχτό σατινέ
- TR Açık gri ipeksi mat

50%

91

0

09

50%

- DE Eisen metallic
- GB Iron metallic
- FR Fer métallique
- NL IJzer metallic
- IT Ferro metallico
- ES Acero metálico
- PT Aço metálico
- DK Stål metallisk
- NO Jern metallic
- SE Stål metallic
- F Teräs metallinen
- RU Сталь металллик
- PL Grafit metaliczny
- CZ Ocelová metalizový
- HU Acélmetál
- SK Ocelová metaliza
- NO Fier metallic
- BG Желязо металик
- SI Železna kovinska
- GR Χρώμα σιδήρου μεταλλικό
- TR Metalik metalik

+

- DE Anthrazit matt
- GB Anthracite matt
- FR Anthracite mat
- NL Antraciet mat
- IT Antracite opaco
- ES Antracita mate
- PT Antracite mate
- DK Antracitgrå mat
- NO Antrasitt matt
- SE Antracitgrå matt
- F Antrasiitinharmaa matta
- RU Антрацит матовый
- PL Antracyt matowy
- CZ Antracitová šedá matný
- HU Antracit, fénytelen
- SK Čierna uhľová matný
- NO Antracit mat
- BG Антрацит матово
- SI Antracit mat
- GR Γκρι ανθρακί ματ
- TR Anthrazit mat

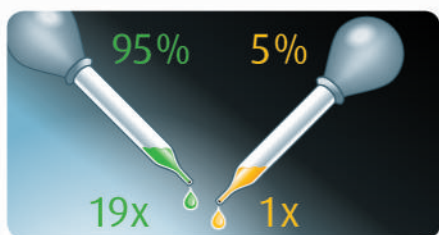

- DE Beispiel: mischen
- GB Example: mixing
- FR Exemple: mélanger
- NL Voorbeeld: mengen
- IT Esempio: mescolare
- ES Ejemplo: mezcla
- PT Exemplo: misturar
- DK Eksempel: blanding
- NO Eksempel: blanding
- SE Exempel: blanda
- F Esimerkki: sekoittaminen

- RU Пример: смешивание
- PL Przykład: mieszanie
- CZ Příklad: míchání
- HU Példa: keverés
- SK Příklad: miešanie
- NO Exemplu: amestecare
- BG Пример: смесване
- SI Primer: mešanje
- GR Παράδειγμα: ανάμειξη
- TR Örnekleştirme

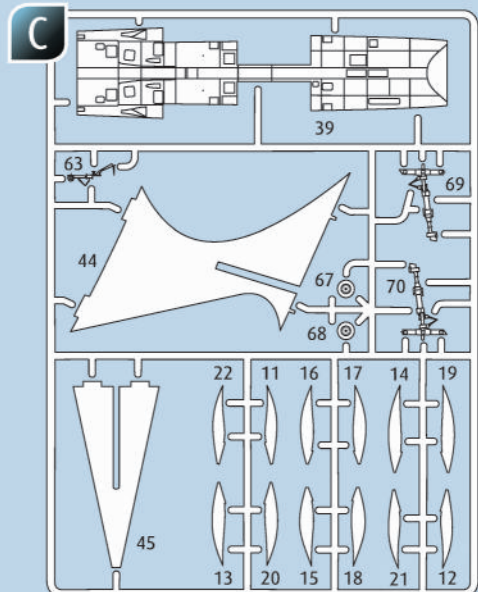
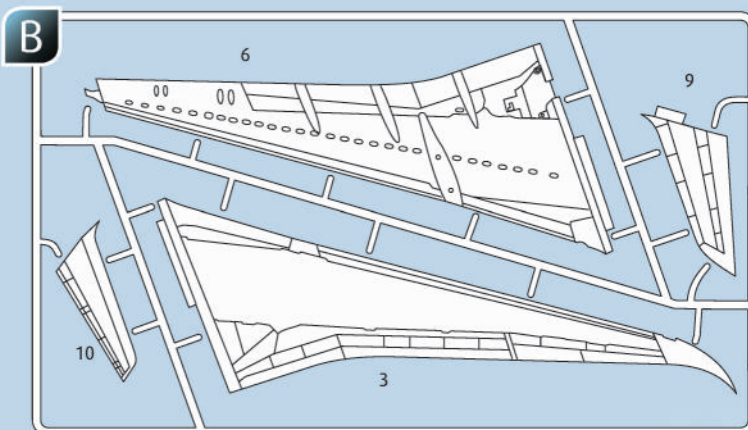
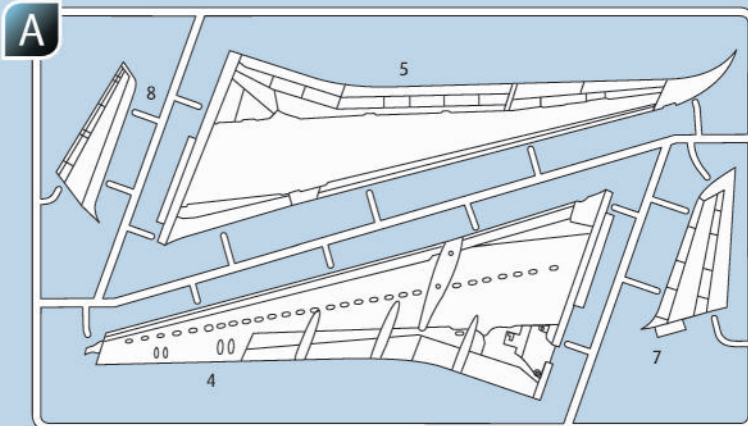
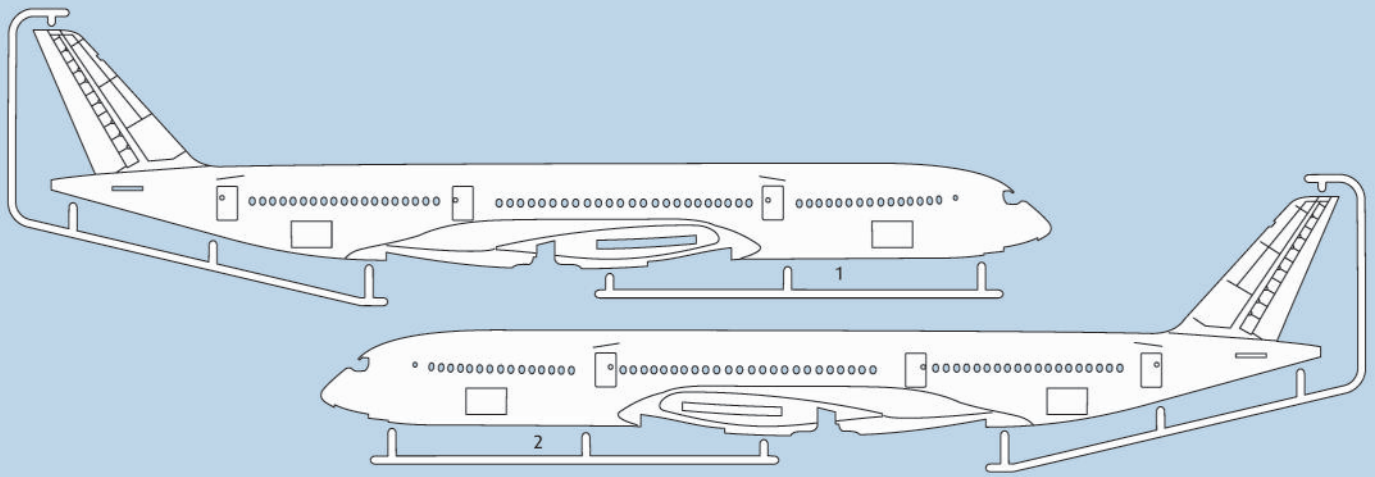

Ersatzteile benötigt?

Kein Problem. Einfach den Revell-Service mit Angabe von Artikel- und Teilenummer kontaktieren. Entweder unter service@revell.de oder Revell GmbH, Abteilung X, Henschelstr. 20-30, 32257 Bünde.*

*Wir bitten um Verständnis, dass eine Gewährleistung nur bei aktuellen Artikeln, die im Zeitraum der letzten 24 Monate erworben wurden, übernommen werden kann. Mit der Ersatzteil-Bestellung können Kosten z.B. für Verpackung und Versand entstehen. Ob diese Kosten anfallen wird im Vorfeld schriftlich durch unseren Service mitgeteilt. Das Angebot kann dann angenommen oder abgelehnt werden. Unfrei eingesandte Ersatzteil-Bestellungen werden von uns nicht angenommen! Dieser Direktservice gilt für die Länder Deutschland, Benelux, Österreich, Frankreich, Großbritannien. Ersatzteil-Bestellungen aus den übrigen Ländern werden über die jeweiligen Distributeure abgewickelt. Bitte kontaktieren Sie Ihren Händler.

Besoin de pièces de rechange ?

Il vous suffit de contacter le service Revell et d'indiquer la référence de l'article et de la pièce. Soit en écrivant par mail à france@revell.de (uniquement pour la France) ou par courrier à Revell GmbH, Département X, Henschelstr. 20-30, D-32257 Bünde.*

*La garantie s'applique pour les articles présents au catalogue et achetés au cours des 24 derniers mois. Merci de votre compréhension. La commande de pièces de rechange peut donner lieu à des frais supplémentaires, par ex. pour l'emballage et le port. Notre service client vous en informera au préalable par écrit. Vous pourrez accepter ou refuser le devis. Nous n'acceptons pas les commandes de pièces de rechange envoyées sans affranchissement ! Ce service direct est valable pour les pays suivants : Allemagne, Benelux, Autriche, France, Grande-Bretagne. Les commandes de pièces en provenance d'autres pays sont traitées par les distributeurs correspondants. Veuillez contacter votre revendeur.

Need spare parts?

No problem. Contact Revell Service with the item number and part numbers you need: service@revell.de or Revell GmbH, Unit 10, Old Airfield Industrial Estate, Cheddington Lane, Tring, Herts, HP23 4QR, Great Britain.*

*We request your understanding that a warranty can only be accepted for current articles which have been purchased in the last 24 months. Orders for spare parts may also be subject to costs for packaging and shipping. You will be notified in advance by our Service department if such costs are incurred. The offer can then be accepted or rejected. We will not be able to process any postal requests unless correct postage has been applied to mailing! This direct service applies to the countries: Germany, Benelux, Austria, France, and the United Kingdom. Spare part orders from other countries are processed by the local distributors. Please contact your dealer.

Hebt u reserveonderdelen nodig?

Geen probleem! Neem eenvoudig contact op met de klantenservice van Revell en geef ons het artikel- en onderdeelnummer door. U kunt ons bereiken op service@revell.de of per post: Revell GmbH, Afdeling X, Henschelstr. 20-30, 32257 Bünde.*

*Wij vragen uw begrip voor de omstandigheid, dat er alleen garantie kan worden geboden voor actuele artikelen, die in de afgelopen 24 maanden zijn gekocht. Met het bestellen van reserveonderdelen kunnen kosten gemoeid zijn, bijv. voor verpakking en verzending. U wordt vooraf schriftelijk door onze klantenservice op de hoogte gesteld als er kosten zouden ontstaan. Het aanbod kan dan worden aangenomen of afgewezen. Wij nemen geen ongefrankeerde bestellingen van reserveonderdelen aan! Deze rechtstreekse service wordt verleend in de landen Duitsland, de Benelux, Oostenrijk, Frankrijk en Groot-Brittannië. Bestellingen van reserveonderdelen in de overige landen worden afgewikkeld via de betreffende distributeurs. Neem hiervoor contact op met uw verkoper.

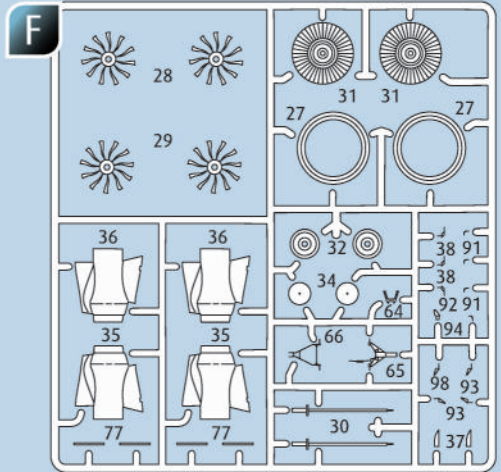
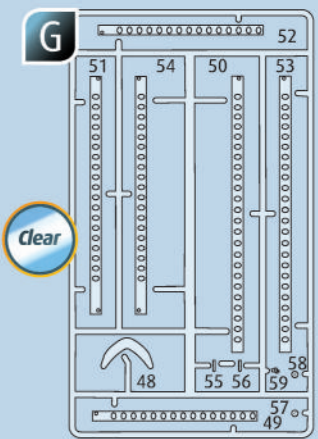
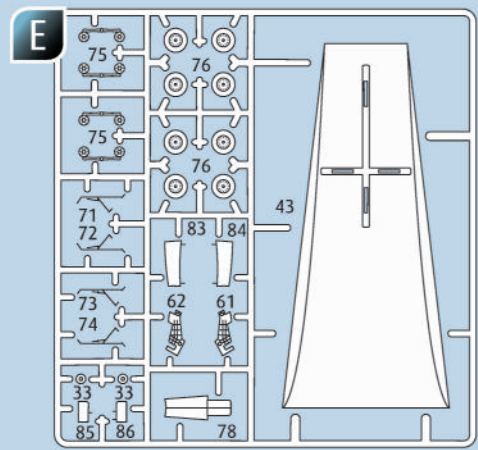
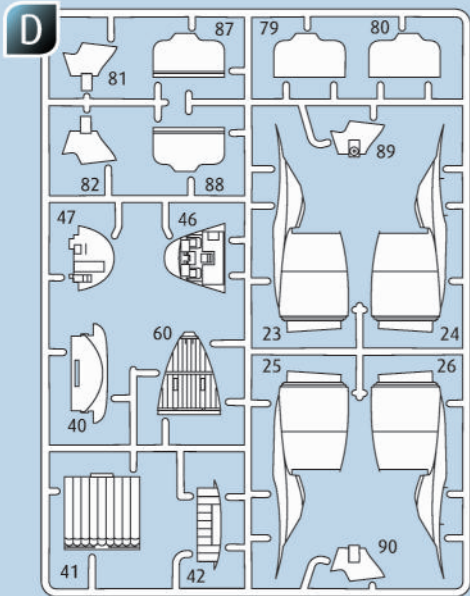

1 ? [Paintbrush icon] [Pen icon]

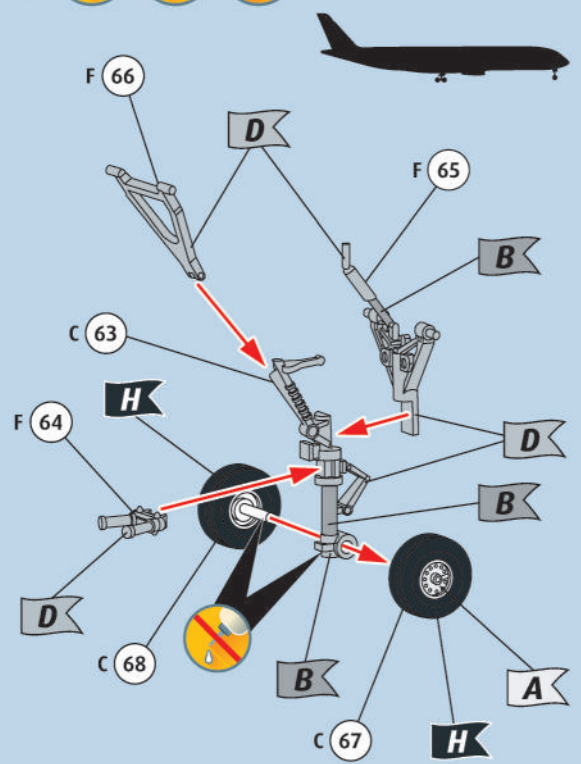

2 ? [Paintbrush icon] [Pen icon]

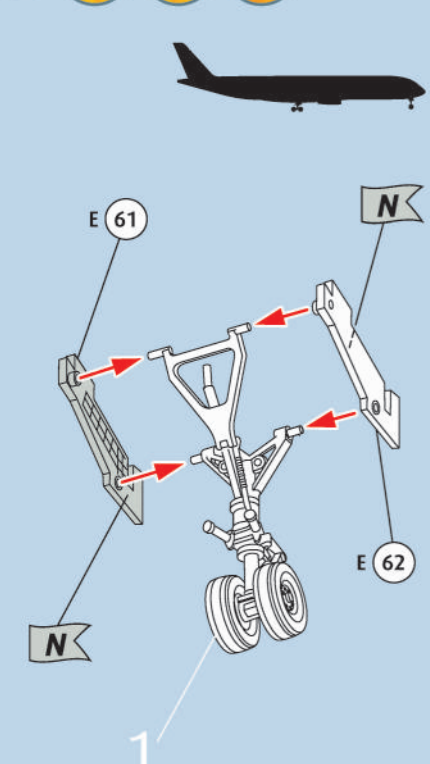

3 ? [Paintbrush icon] [Pen icon] [Clock icon]

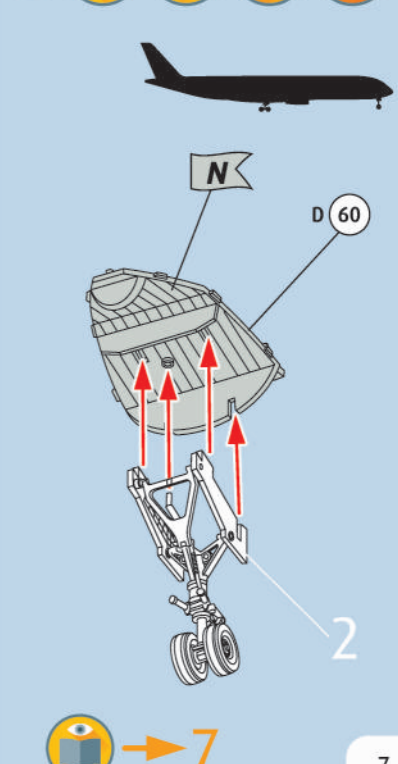



4

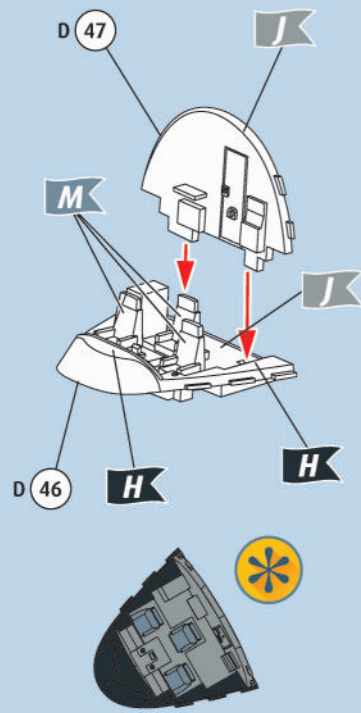

5

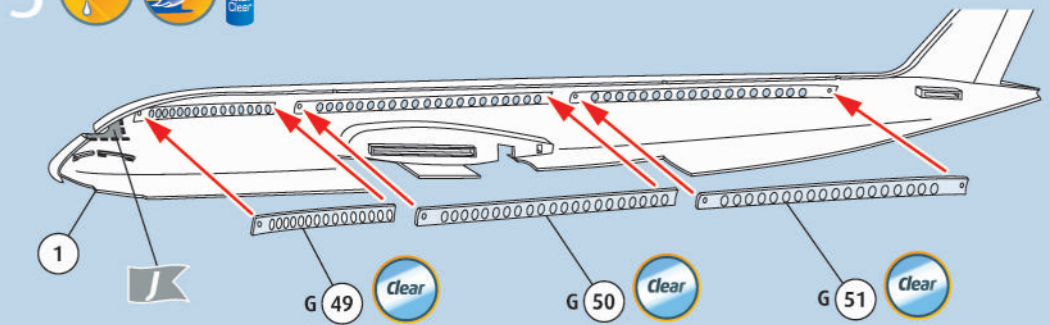

6

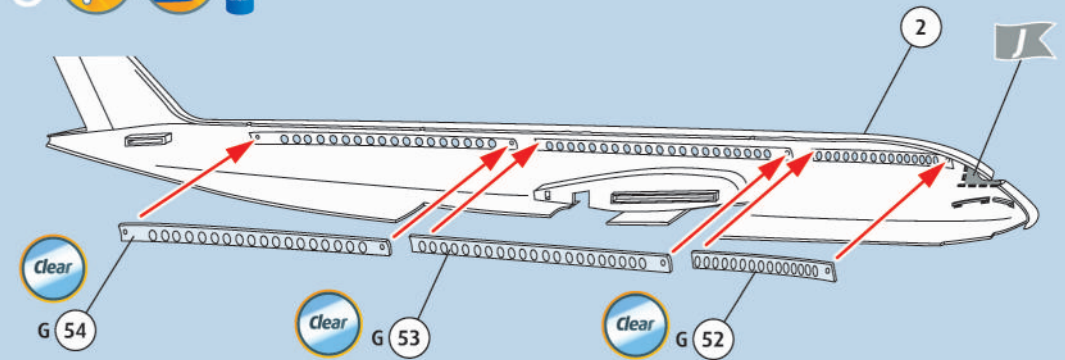

7

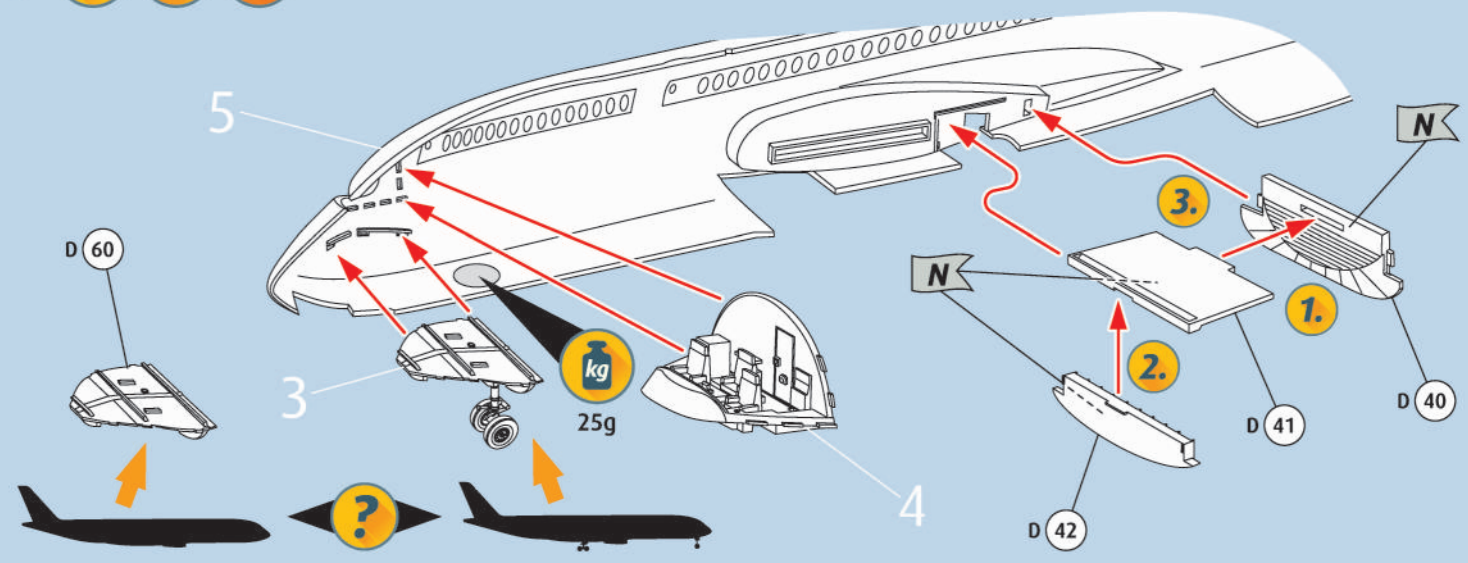

8

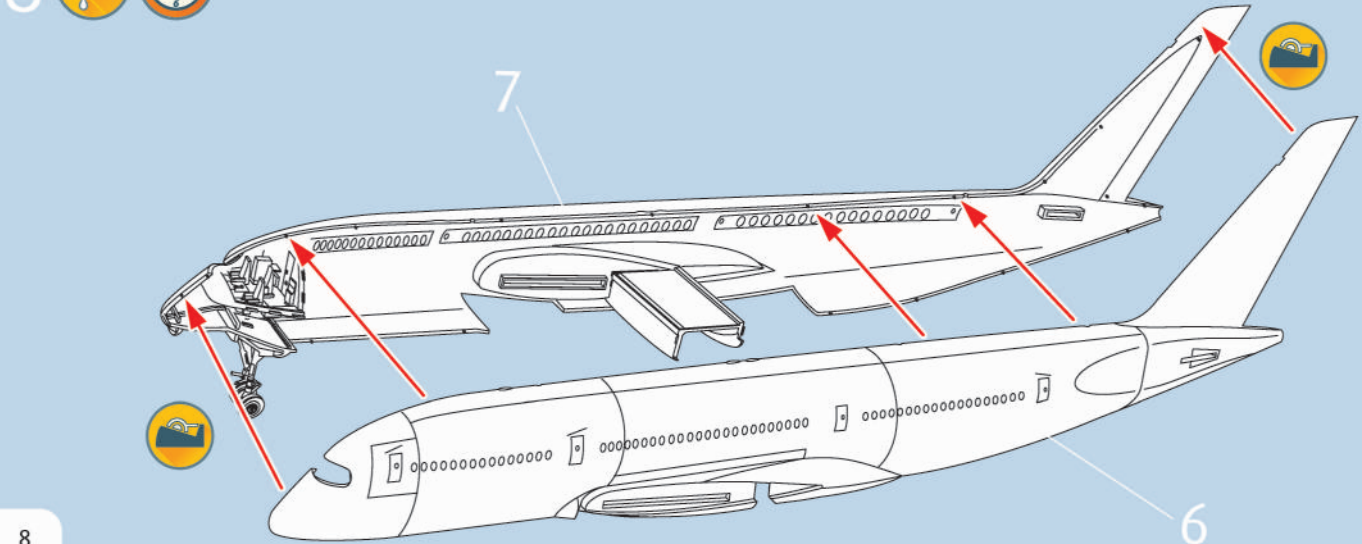

9

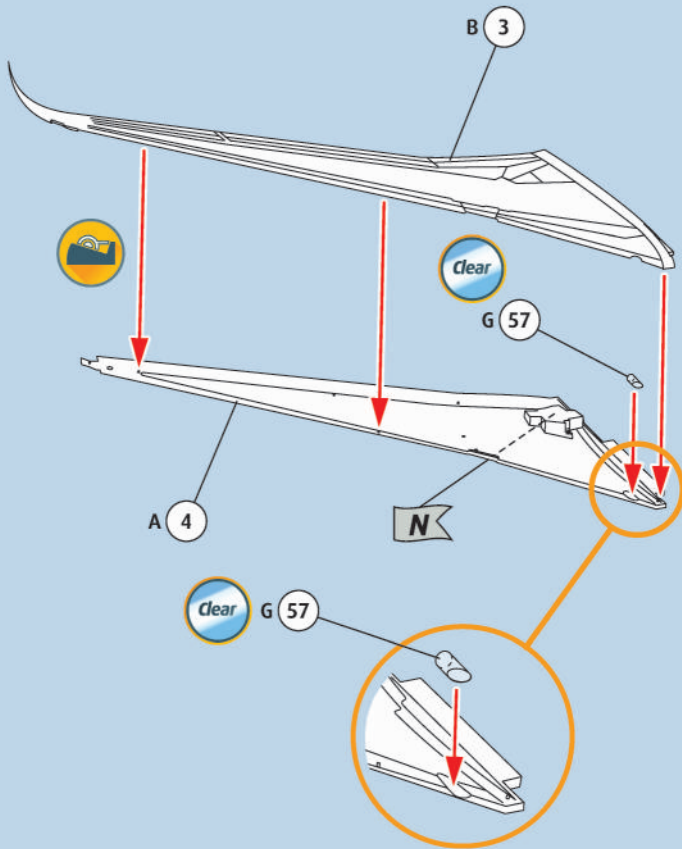

10

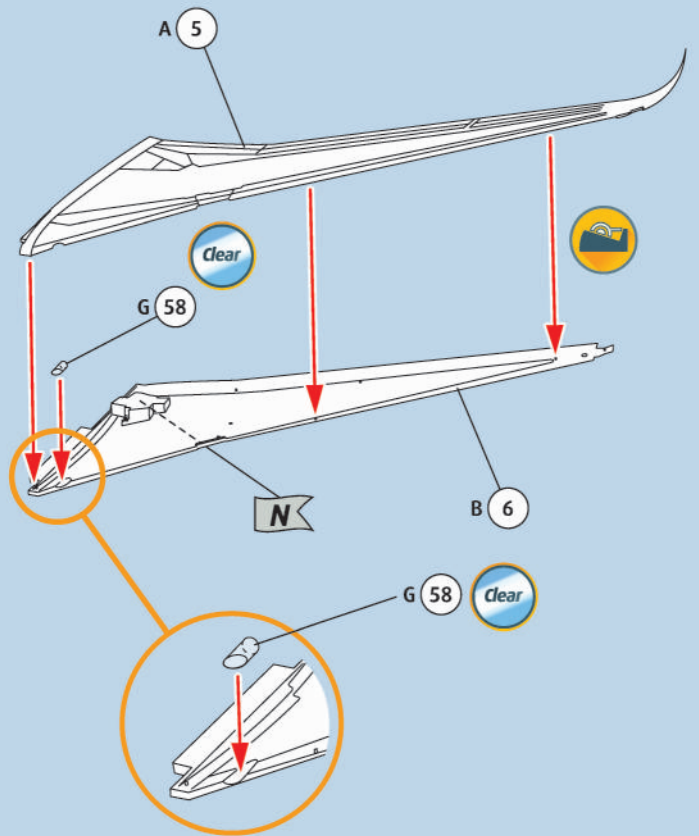

11

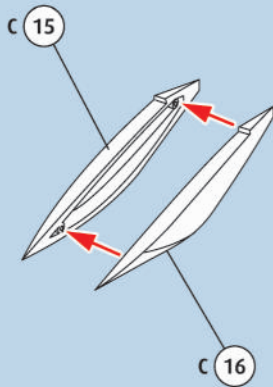

12

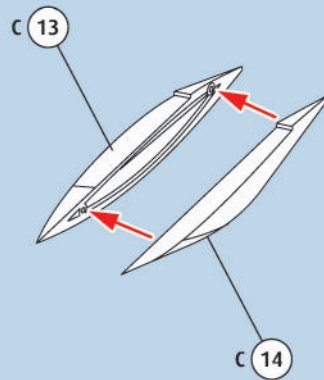

13

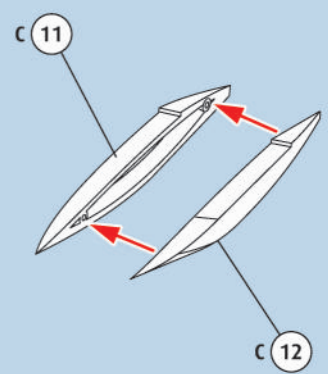

14

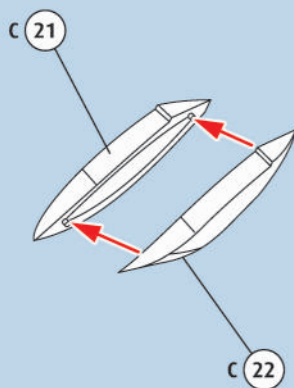

15

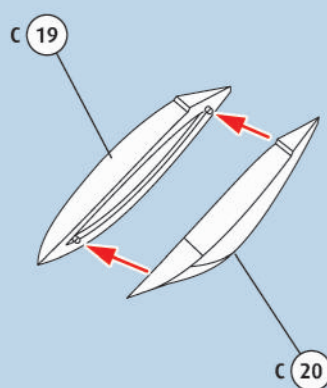

16

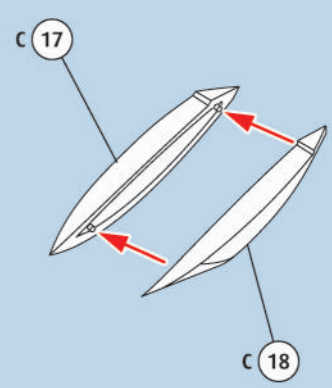

17   

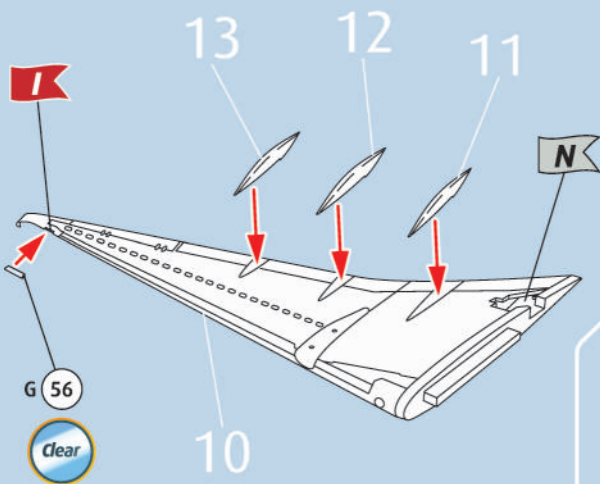

18   

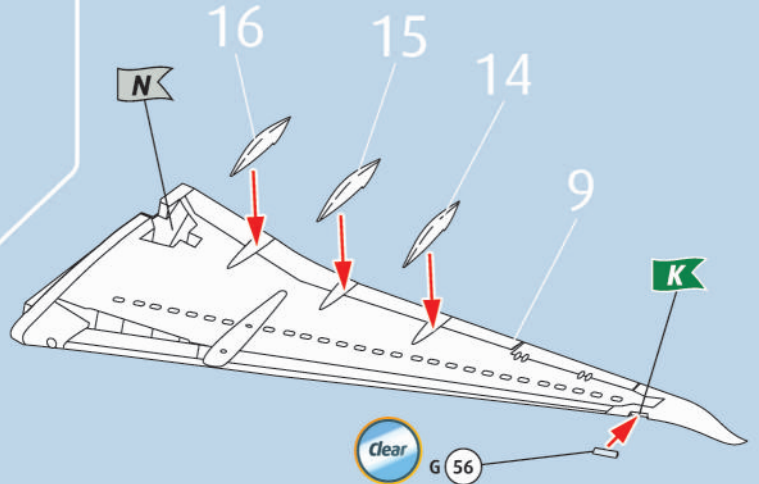

19 

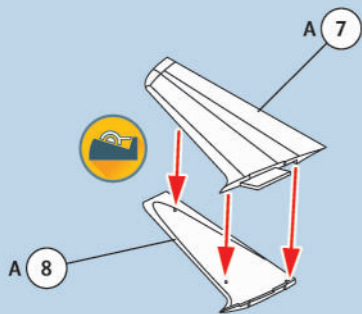

20 

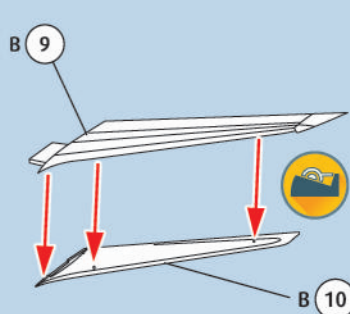

21  

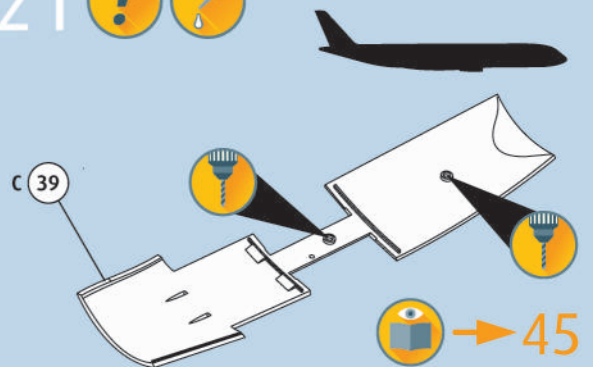

22   

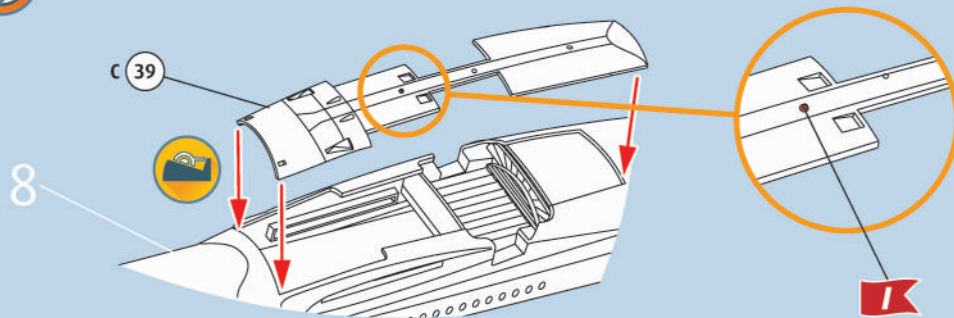

23    

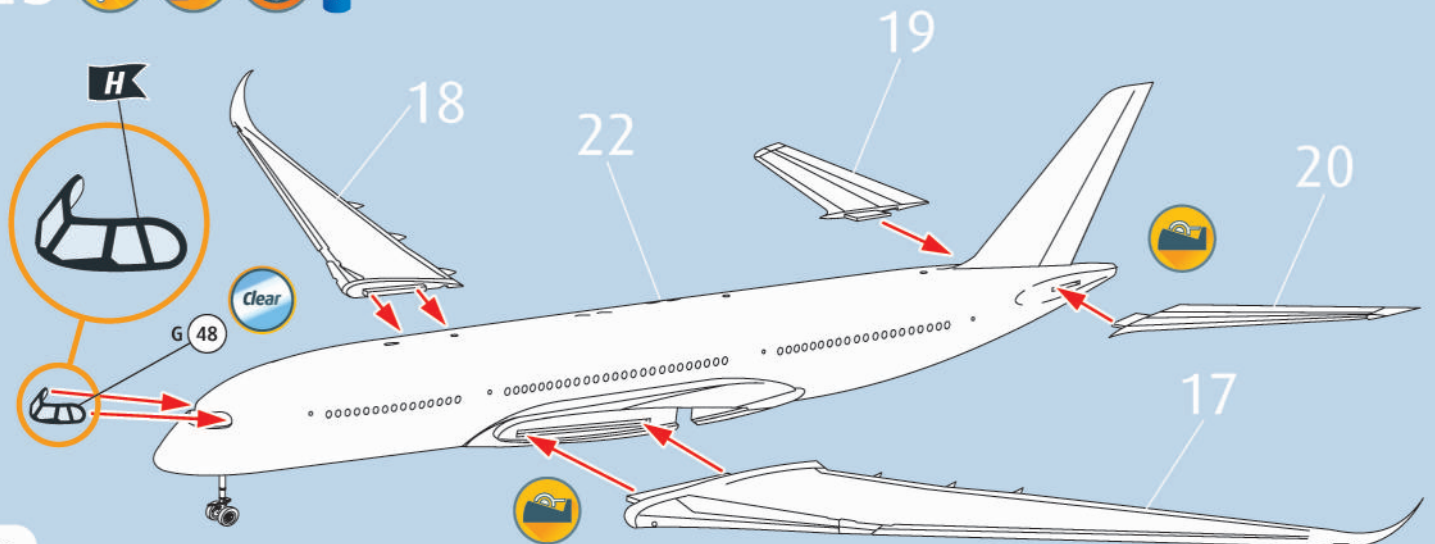

24   

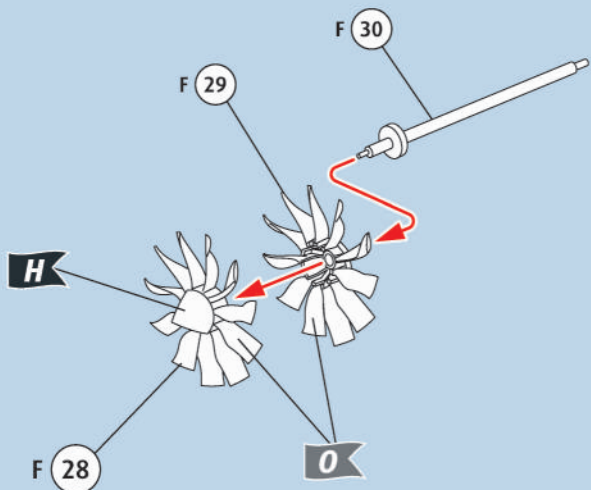

25   

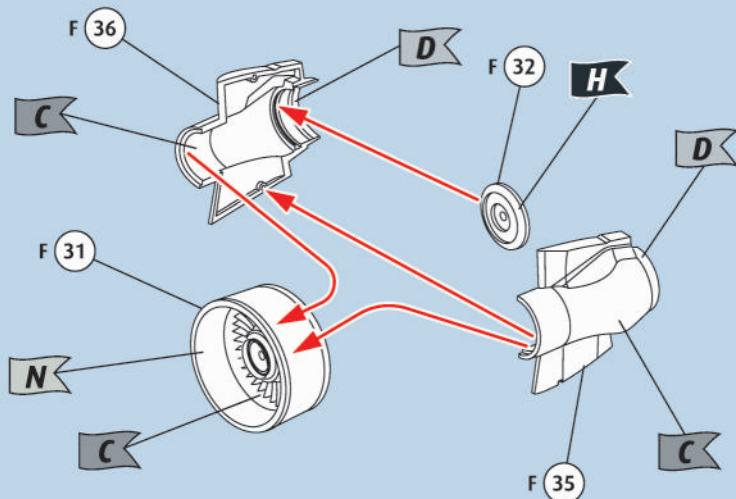

26   

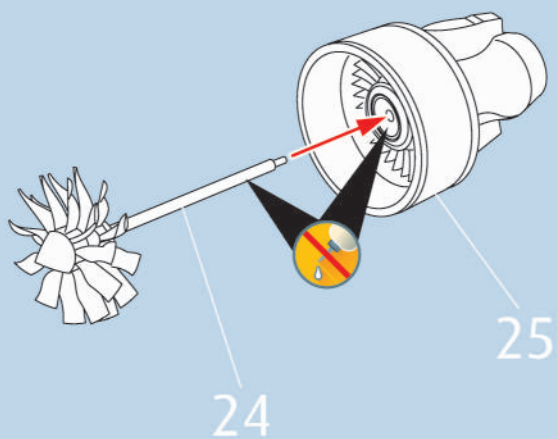

27  

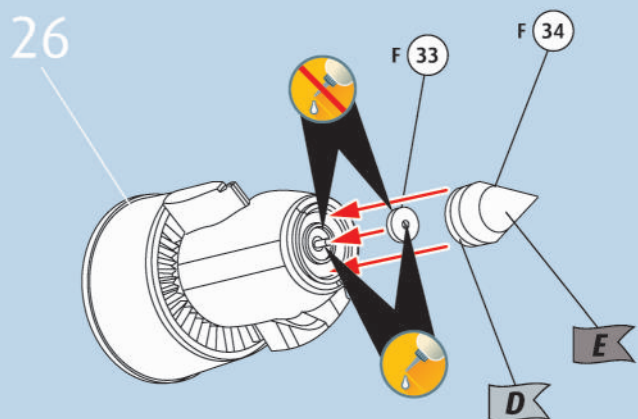

28   

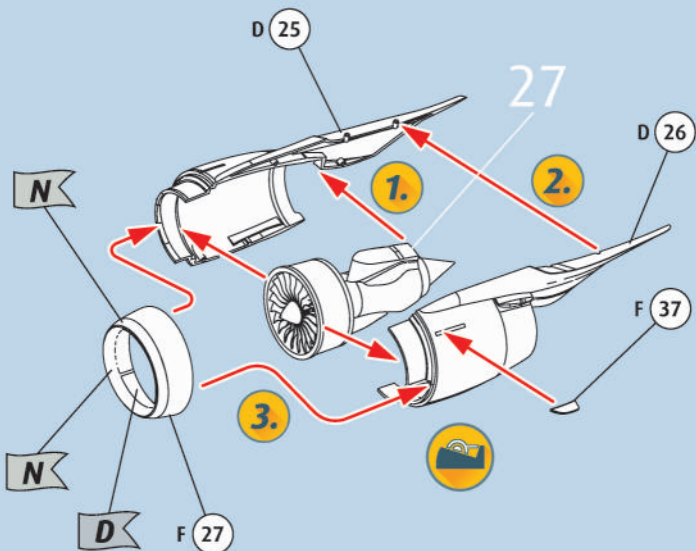

29   

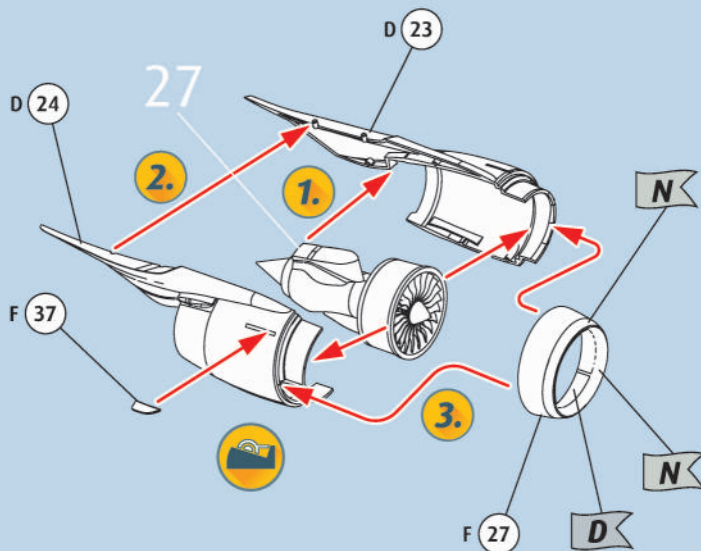

30   

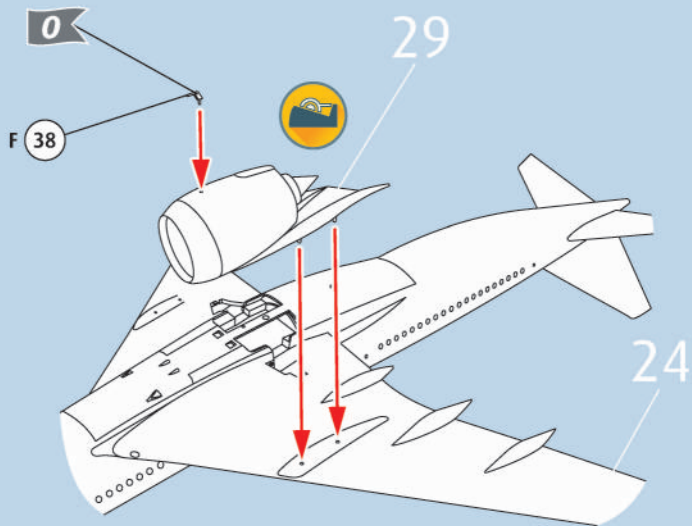

31   

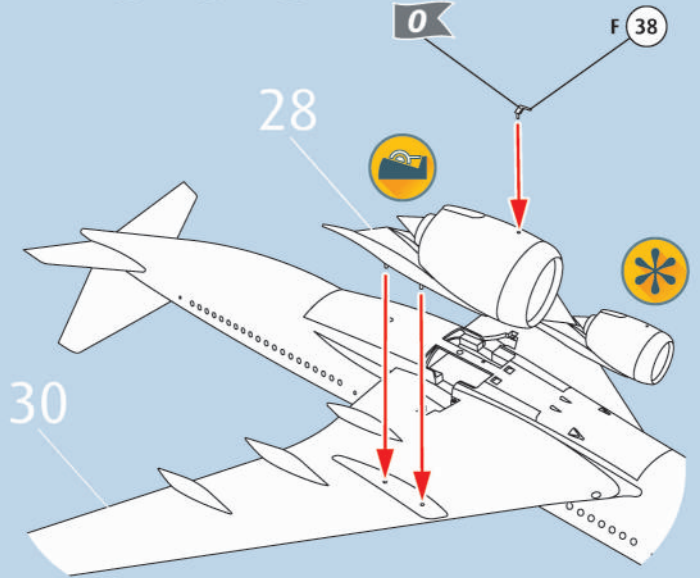

32    

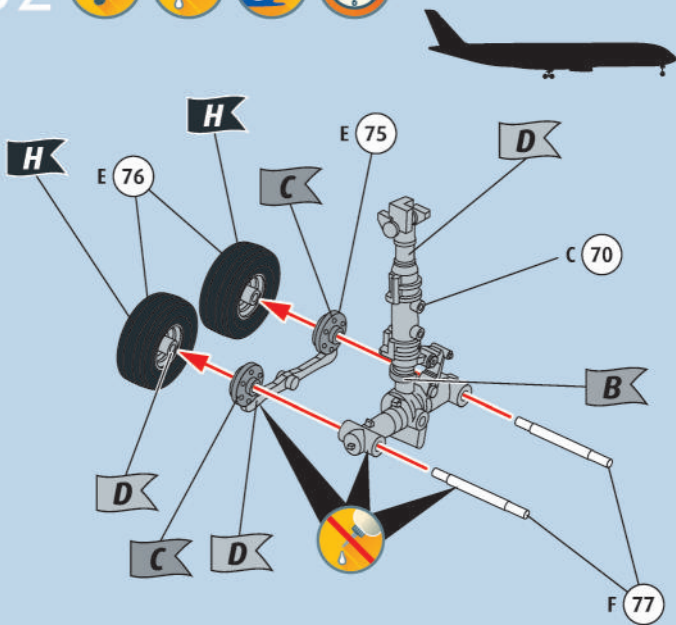

33    

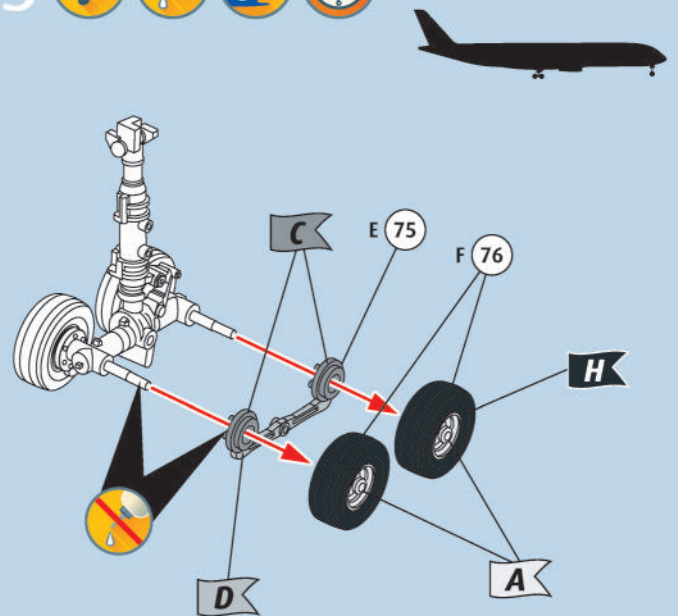

34    

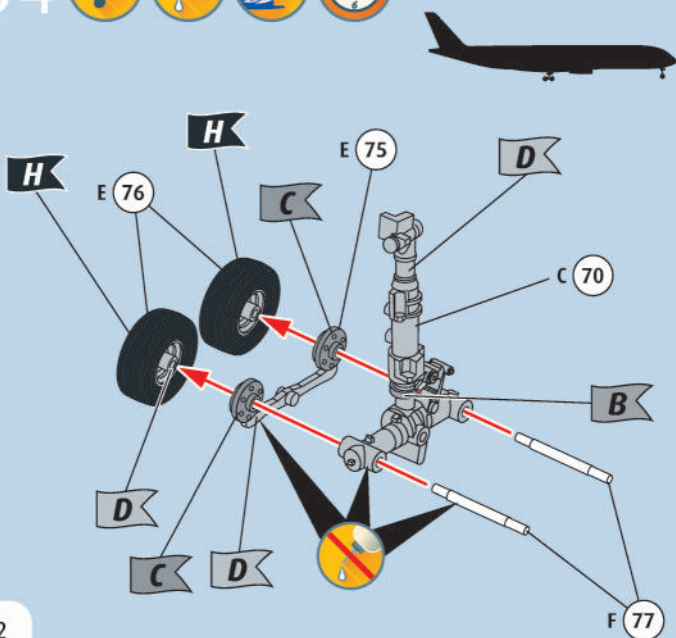

35    

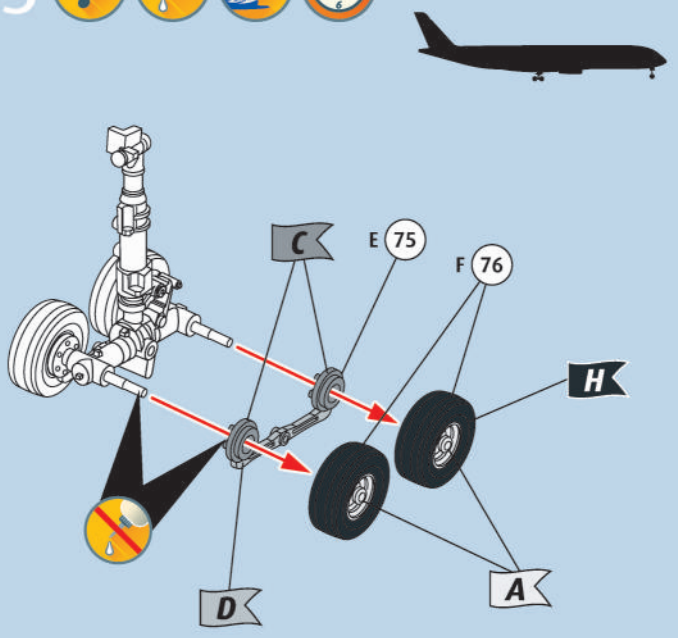

36 ? [Screwdriver] [Pencil] [Clock]

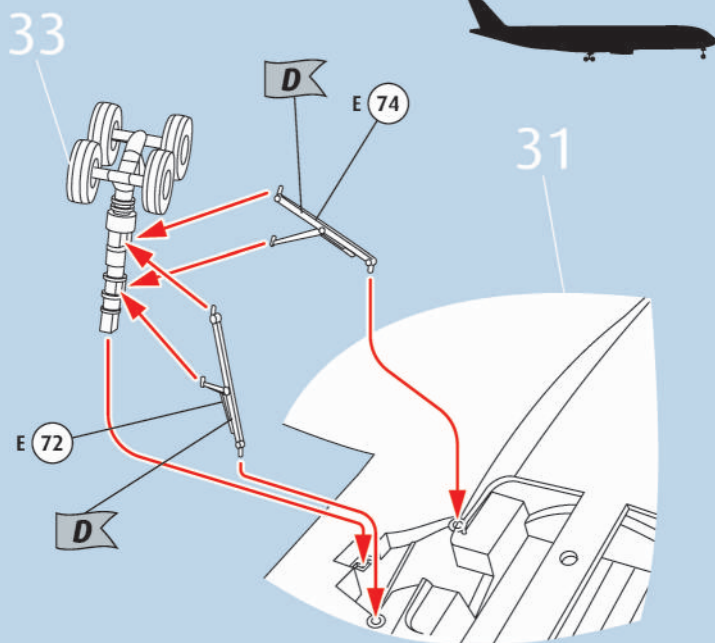

37 ? [Screwdriver] [Pencil] [Clock]

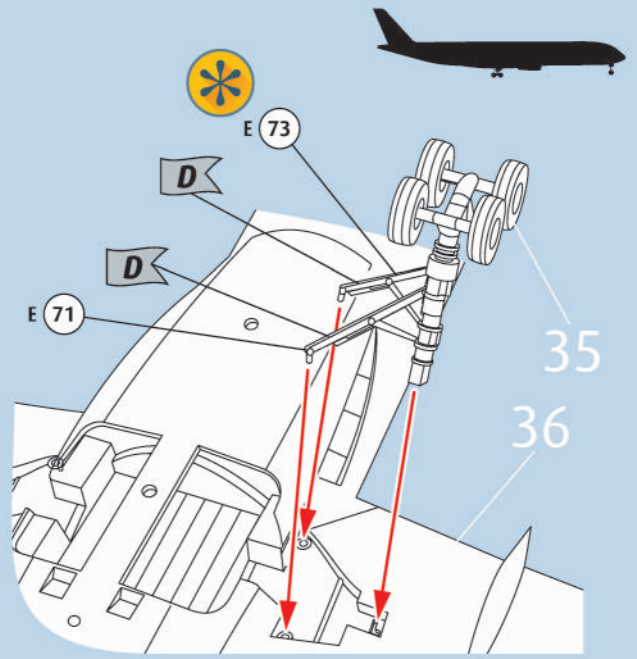

38 ? [Screwdriver] [Pencil] [Clock]

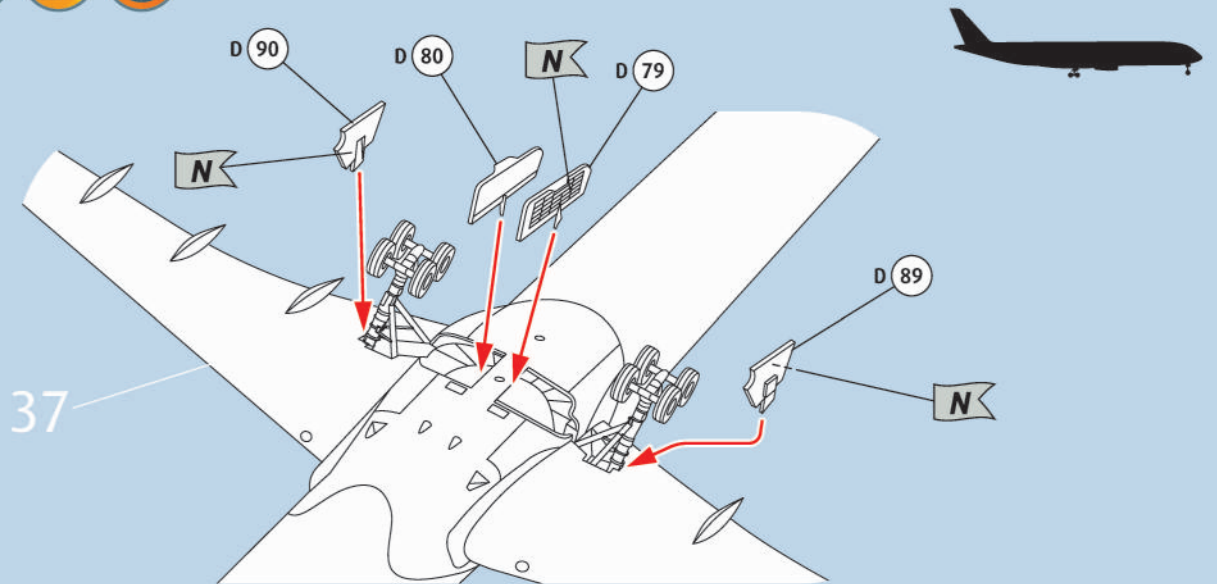

39 ? [Pencil]

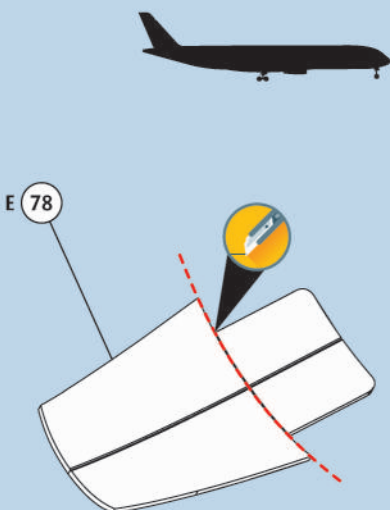

40 ? [Screwdriver] [Pencil] [Clock]

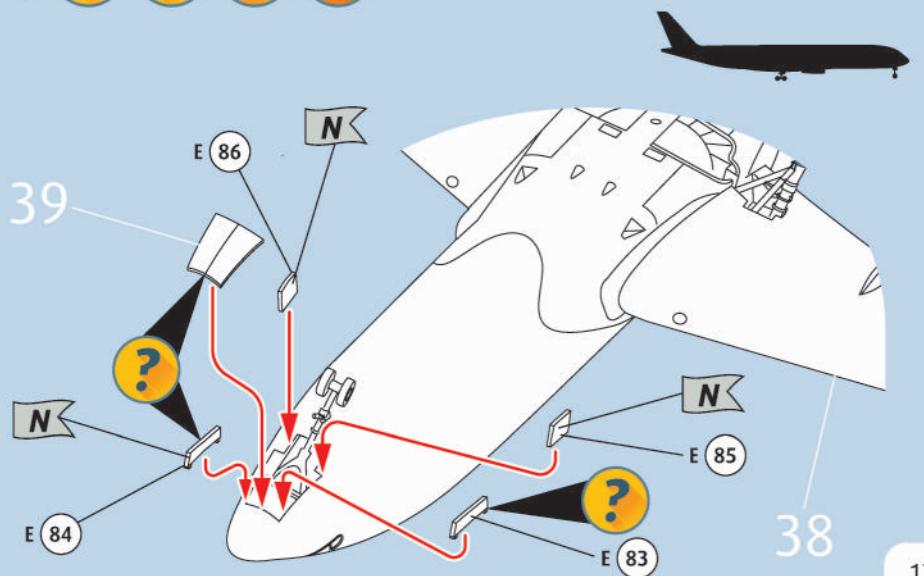

41

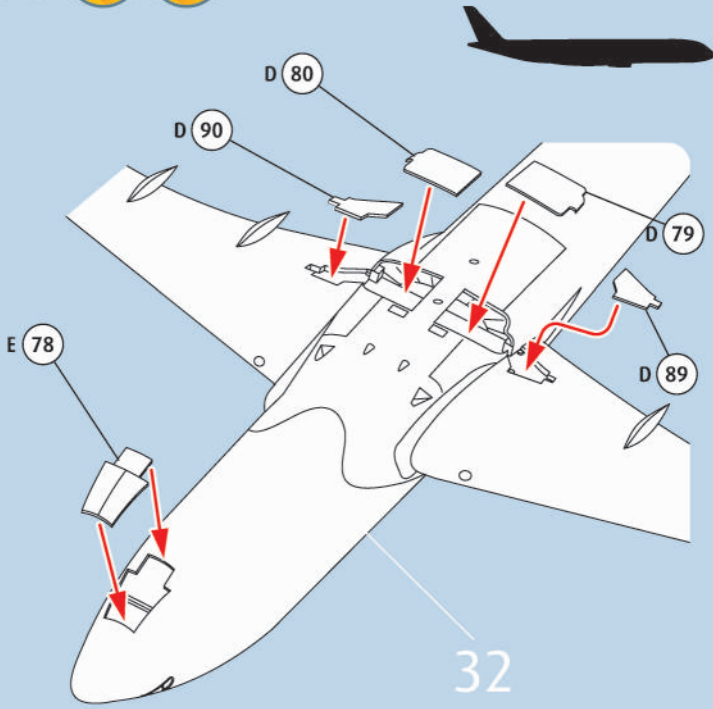

42

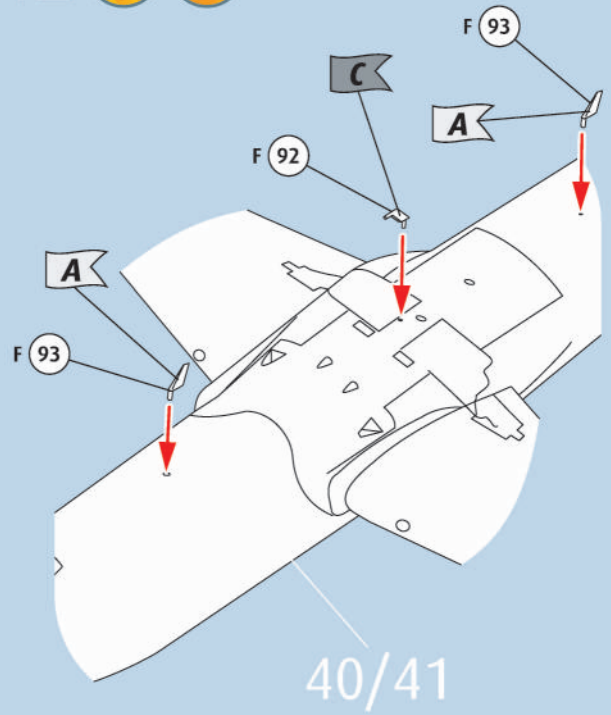

43

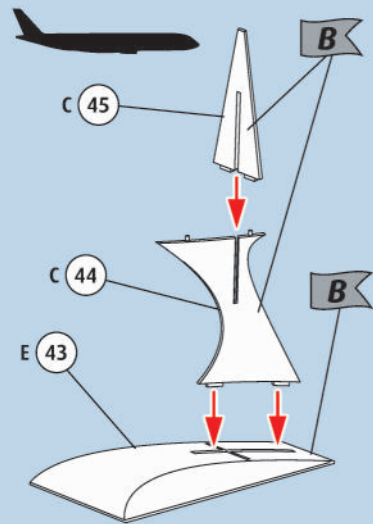

44

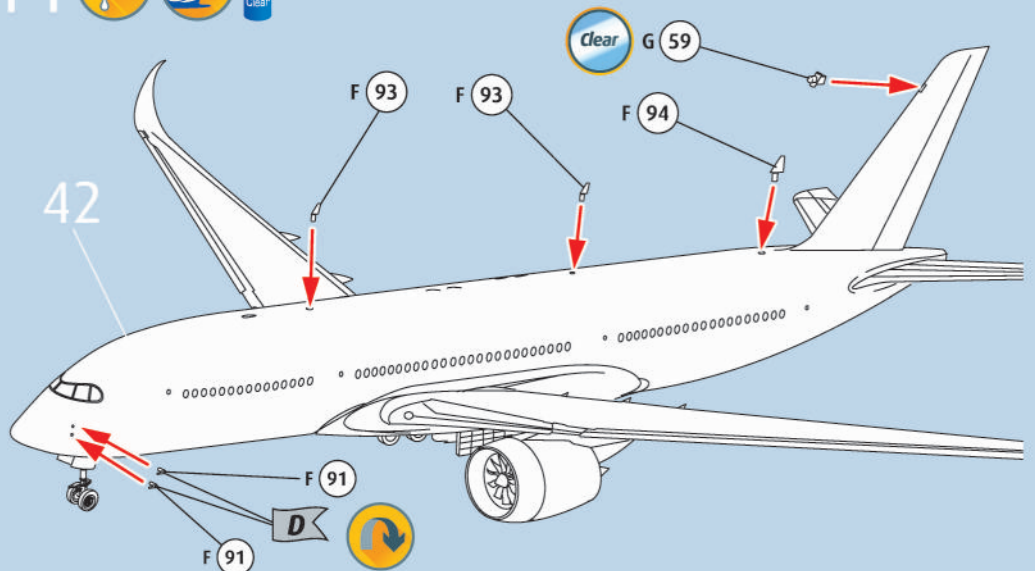

45

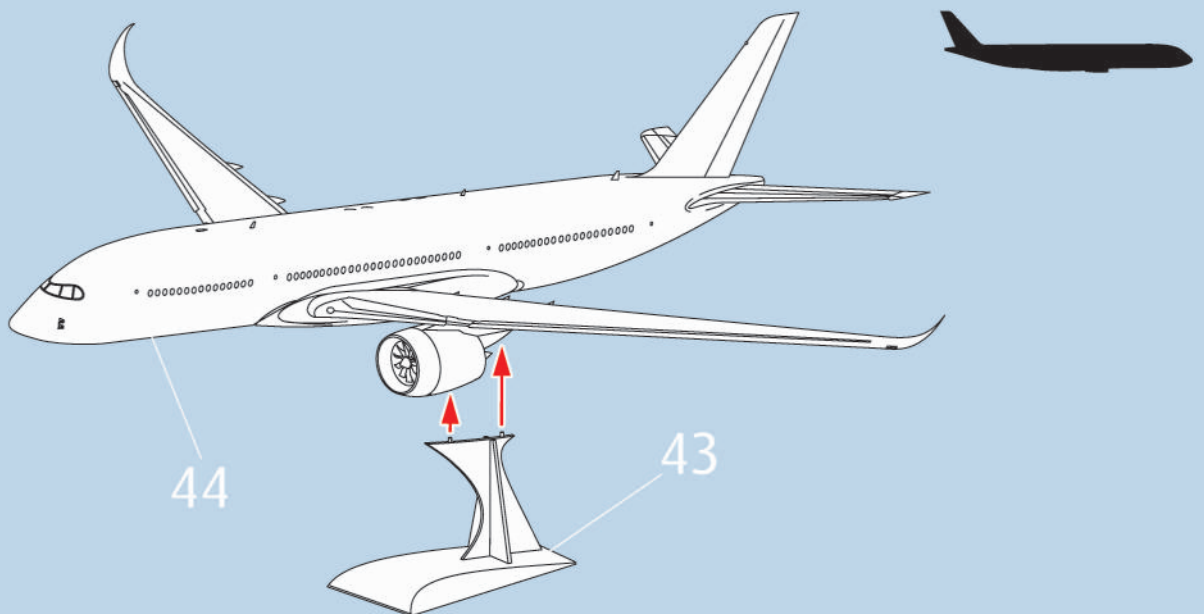



Airbus A350-900 Lufthansa New Livery



