

## MASTER SERIES

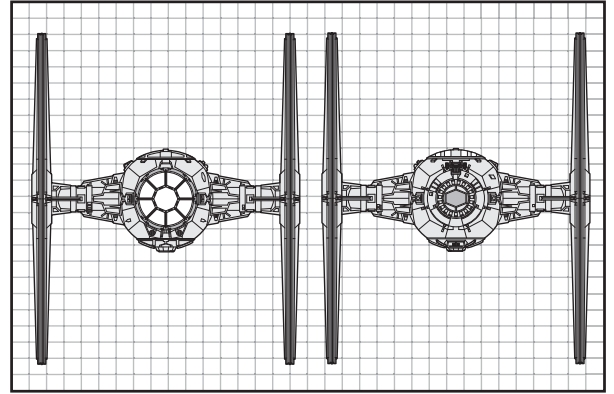
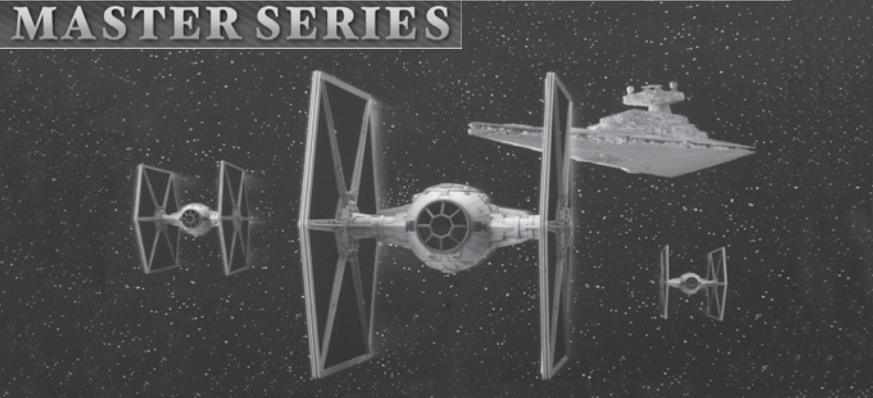

The TIE (Twin Ion Engine) Fighter™ is the primary combat vehicle of the Empire. It is manufactured by Sienar Fleet Systems, along with the other TIE Fighter designs. This basic TIE Fighter is equipped with twin engines that give it high speed capabilities while maintaining superior maneuverability. The distinctive twin hexagon solar panels supply all the power to the fighter. However, the TIE Fighter does not have a life support system, and the pilot must rely on his sealed suit for his air supply. The TIE Fighter pilot takes an oath of loyalty to the Emperor and is willing to die if necessary. So, the TIE Fighter lacks an ejection system to save weight. The TIE Fighters have been produced in overwhelming numbers in the quest to defeat the Rebels.

TIE (Twin Ion Engine ou moteurs à ions jumeaux) Fighter™ est le principal véhicule de combat de l'Empire. Il est fabriqué par la firme Sienar Fleet Systems, comme tous les autres chasseurs au design TIE. Ce chasseur TIE de base est équipé avec des moteurs jumeaux qui lui confèrent des capacités de haute vitesse tout en maintenant une maniabilité supérieure. Ses panneaux solaires de forme distinctive en hexagone jumeau lui fournissent toute l'alimentation au chasseur. Toutefois, le chasseur TIE n'est pas muni de systèmes de soutien de la vie et le pilote doit se fier uniquement sur sa combinaison scellée pour une alimentation en air. Le pilote du chasseur TIE doit prononcer un serment de loyauté à l'Empereur et accepter de mourir si nécessaire. Ainsi, le chasseur TIE n'a pas de système d'éjection afin d'économiser du poids. Les chasseurs TIE ont été produits en quantité impressionnante dans cette quête en vue de défaire les rebelles.

El TIE (Motor de iones doble) Fighter™ es el vehículo de combate principal del Imperio. Es fabricado por Sienar Fleet Systems, junto con los otros diseños del TIE Fighter. Este TIE Fighter básico está equipado con motores dobles que le proporcionan capacidades de alta velocidad mientras mantiene una maniobrabilidad superior. Los distintivos paneles solares hexagonales dobles brindan toda la potencia al avión de combate. Sin embargo, el TIE Fighter no tiene un sistema de apoyo vital, y el piloto debe depender en su traje sellado para su suministro de aire. El piloto del TIE Fighter toma un juramento de lealtad al Emperador y está dispuesto a morir si es necesario. Por lo tanto el TIE Fighter carece de un sistema de eyección para ahorrar peso. Los TIE Fighter han sido producidos en número sorprendentes en la búsqueda de vencer a los Rebeldes.

### READ THIS BEFORE YOU BEGIN

- \* Study the assembly drawings.
- \* Each plastic part is identified by a number.
- \* In the assembly drawings, some parts will be marked by a star  to indicate chrome plated plastic.
- \* For better paint and decal adhesion, wash the plastic parts in a mild detergent solution. Rinse and let air dry.
- \* Check the fit of each piece before cementing in place.
- \* Use only cement for polystyrene plastic.
- \* Scrape plating and paint from areas to be cemented.
- \* Allow paint to dry thoroughly before handling parts.
- \* Any unused parts may be discarded.

### LISEZ CECI AVANT DE COMMENCER

- \* Étudiez les plans d'assemblage.
- \* Chaque pièce de plastique est identifiée par un numéro.
- \* Dans les plans d'assemblage, certaines pièces seront marquées d'une étoile  pour indiquer des pièces en plastique plaquées chrome.
- \* Pour une meilleure adhésion de la peinture et de la décalcomanie, lavez les pièces en plastique dans une solution de détergent doux. Rincez et laissez sécher à l'air.
- \* Vérifiez l'ajustement de chaque pièce avant de la coller en place.
- \* Utilisez uniquement de la colle pour plastique au polystyrène.
- \* Grattez toute peinture et le placage sur les régions à coller.
- \* Laissez sécher la peinture complètement avant de manipuler des pièces.
- \* Toute pièce non-utilisée peut être jetée.

### LEA ESTO ANTES DE EMPEZAR

- \* Estudie los dibujos de ensamblaje.
- \* Cada parte plástica está identificada con un número.
- \* En los dibujos de ensamblaje, algunas partes aparecerán marcadas con una estrella  para indicar plástico enchapado en cromo.
- \* Para mejor adhesión de pintura y calcomanías, lave las partes plásticas en una solución de detergente suave. Enjuague y deje secar al aire.
- \* Verifique el encastrado de cada pieza antes de cementar en su lugar.
- \* Use sólo cemento para plástico de poliestireno.
- \* Raspe las placas y la pintura de las áreas a cementar.
- \* Deje secar la pintura totalmente antes de manipular las partes.
- \* Cualesquiera partes sin usar se pueden descartar.

### CUSTOMER SERVICE

If you have questions, comments or problems visit our website [revell.com](http://revell.com) or write to us at:

**Revell Inc. Consumer Service**  
1850 Howard St. Unit A  
Elk Grove Village, IL 60007

Be sure to include this plan number (85509200200), part number, description and your return address and phone number.

### SERVICE À LA CLIENTÈLE

Pour toute question, problème ou commentaire, visitez-nous à l'adresse [revell.com](http://revell.com) ou écrivez-nous à :

**Revell Inc. Consumer Service**  
1850 Howard St. Unit A  
Elk Grove Village, IL 60007

Assurez-vous d'inclure ce numéro de plan (85509200200), le numéro de pièce, une description ainsi que votre adresse de retour et numéro de téléphone.

### SERVICIO AL CLIENTE

Si tiene preguntas, comentarios o problemas, visite nuestro sitio web [revell.com](http://revell.com) o escríbanos a:

**Revell Inc. Consumer Service**  
1850 Howard St. Unit A  
Elk Grove Village, IL 60007

Asegúrese de incluir el número de plano (85509200200), el número de parte, la descripción y su dirección y número de teléfono para responder.

<b>PAINT GUIDE</b>	<b>GUIDE DE PEINTURE</b>	<b>GUÍA DE PINTURA</b>
<b>A</b> Brown	Brun	Marrón
<b>B</b> Flat Black	Noir mat	Negro mate
<b>C</b> Flesh	Chair	Carne
<b>D</b> Light Gray	Gris clair	Gris claro
<b>E</b> Neutral Gray	Gris neutre	Gris neutro
<b>F</b> Semi Gloss Black	Noir satiné	Negro semibrillante
<b>G</b> Silver	Argent	Plata
<b>H</b> Transparent Orange	Orange transparent	Anaranjado transparente

<b>DECAL APPLICATION INSTRUCTIONS</b>
<ol style="list-style-type: none"> <li>1. Cut desired decal from sheet.</li> <li>2. Dip decal in water for a few seconds.</li> <li>3. Place wet decal on paper towel.</li> <li>4. Wait until decal is movable on paper backing.</li> <li>5. Place decal in position on model, face up and slide backing away.</li> <li>6. Press out air bubbles with a soft damp cloth.</li> <li>7. Milkiness that may appear is for better decal adhesion and will dry clear. Wipe away any excess adhesive.</li> <li>8. Do not touch decal until fully dry.</li> <li>9. Allow the decals 48 hours to dry before applying clear coat.</li> <li>10. Decals are compatible with setting solutions or solvents.</li> </ol>

<b>INSTRUCTIONS POUR L'APPLICATION DE DÉCALCOMANIE</b>
<ol style="list-style-type: none"> <li>1. Découpez la décalcomanie désirée sur la feuille.</li> <li>2. Trempez la décalcomanie durant quelques secondes dans l'eau.</li> <li>3. Placez la décalcomanie sur une serviette de papier.</li> <li>4. Attendez jusqu'à ce que la décalcomanie puisse être retirée de l'endos en papier.</li> <li>5. Placez la décalcomanie en position sur votre modèle, face vers le haut, et retirez l'endos.</li> <li>6. Pressez pour évacuer les bulles d'air avec un chiffon doux humide.</li> <li>7. La formation d'un voile blanchâtre qui pourrait apparaître sert à la meilleure adhésion de la décalcomanie et deviendra claire une fois séchée. Nettoyez tout excès d'adhésif.</li> <li>8. Ne touchez pas la décalcomanie tant qu'elle ne sera pas entièrement séchée.</li> <li>9. Laissez sécher la décalcomanie durant 48 heures avant d'appliquer un enduit protecteur.</li> <li>10. Les décalcomanies sont compatibles avec les solutions de séchage et les solvants.</li> </ol>

<b>INSTRUCCIONES DE APLICACIÓN DE CALCOMANÍAS</b>
<ol style="list-style-type: none"> <li>1. Corte la calcomanía deseada de la lámina.</li> <li>2. Sumerja la calcomanía en agua por unos segundos.</li> <li>3. Coloque la calcomanía húmeda sobre una toalla de papel.</li> <li>4. Espere hasta que la calcomanía se mueva en la lámina posterior de papel.</li> <li>5. Coloque la calcomanía en posición sobre el modelo, con la cara hacia arriba y deslice la lámina posterior hasta quitarlo.</li> <li>6. Presione para quitar las burbujas de aire con un trapo suave húmedo.</li> <li>7. La lechosidad que puede aparecer es para una mejor adhesión de la calcomanía y se secará completamente. Limpie cualquier exceso de adhesivo.</li> <li>8. No toque la calcomanía hasta que esté totalmente seca.</li> <li>9. Deje secar las calcomanías 48 horas antes de aplicar "clear coat".</li> <li>10. Las calcomanías son compatibles con las soluciones de fijación o los solventes.</li> </ol>



\* REPEAT SEVERAL TIMES  
\* A RÉPÉTEZ PLUSIEURS FOIS  
\* REPITA VARIAS VECES



\* REPEAT PROCEDURE  
\* RÉPÉTEZ LA PROCÉDURE  
\* REPITA EL PROCEDIMIENTO



\* OPTIONAL PARTS  
\* PIÈCES OPTIONNELLES  
\* PARTES OPCIONALES



\* DECAL  
\* DÉCALCOMANIE  
\* CALCOMANÍA



\* ASSEMBLY CAUTION  
\* AVERTISSEMENT POUR L'ASSEMBLAGE  
\* PRECAUCIÓN DE ENSAMBLAJE



\* CEMENT TOGETHER  
\* COLLER ENSEMBLE  
\* CEMENTAR Y UNIR



\* REMOVE AND THROW AWAY  
\* RETIREZ ET JETER  
\* RETIRE Y DESCARTE



\* DO NOT CEMENT  
\* NE PAS COLLER  
\* NO CEMENTAR



\* OPEN HOLE  
\* LAISSEZ SÉCHER LES PIÈCES  
\* ABRA AGUJERO



\* REMOVE TAPE  
\* RUBAN AMOVIBLE  
\* CINTA DEMONTABLE



\* RUBBER BAND TOGETHER  
\* SERRER ENSEMBLE AVEC UNE BANDE ÉLASTIQUE  
\* UNA CON BANDA ELÁSTICA



\* STICKER DECAL  
\* DÉCALCOMANIE AUTOCOLLANTE  
\* CALCOMANÍA AUTOADHESIVA



\* WEIGHT  
\* POIDS  
\* PESO



\* TRIM OFF  
\* DÉCOUPEZ  
\* RECORTE



\* HEATED SCREWDRIVER END  
\* POINTE CHAUFFÉE DE TOURNEVIS  
\* EXTREMO DE DESTORNILLADOR CALENTADO

1

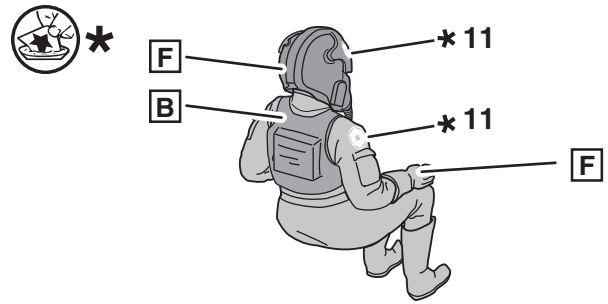
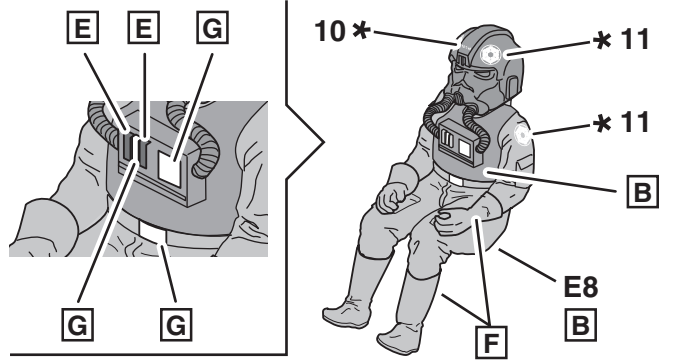
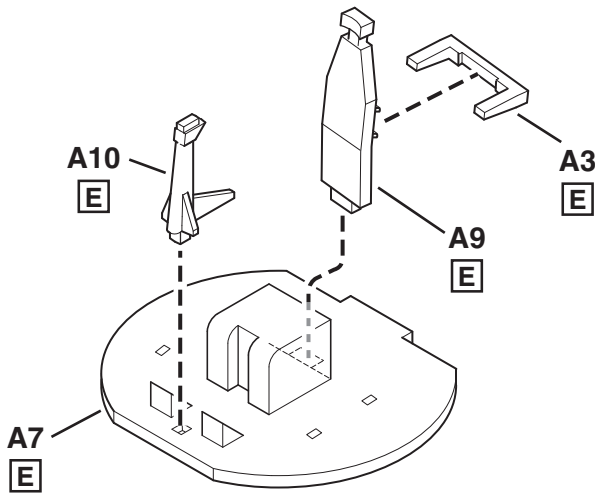

2

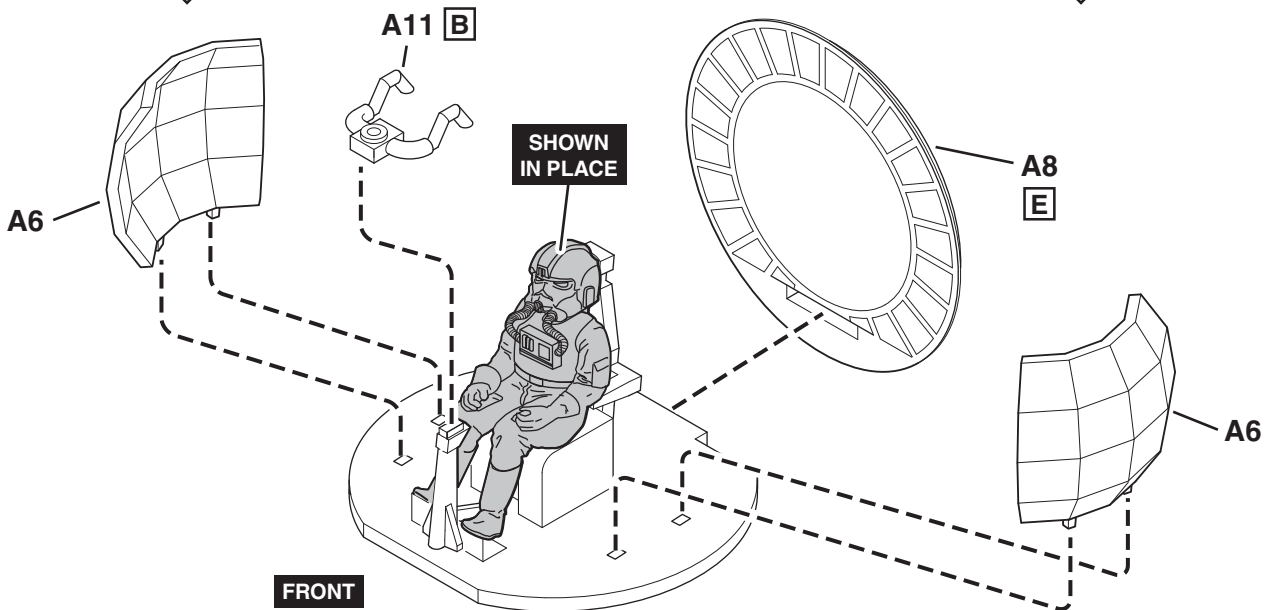
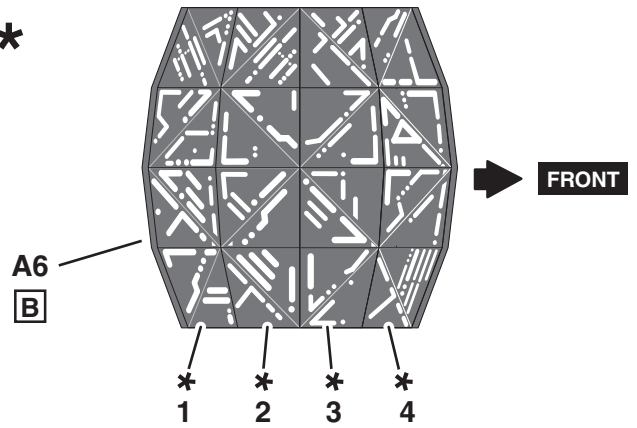
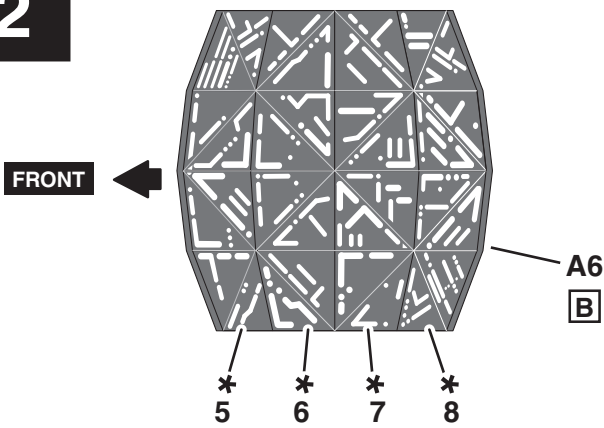



5

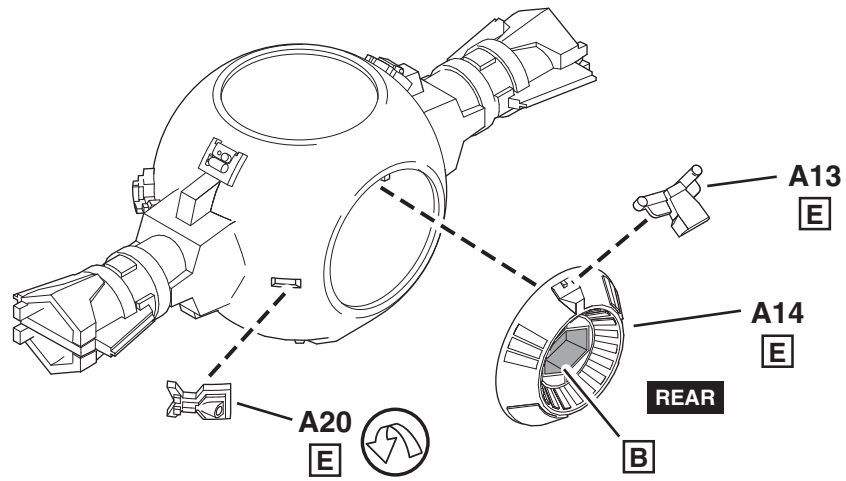

6

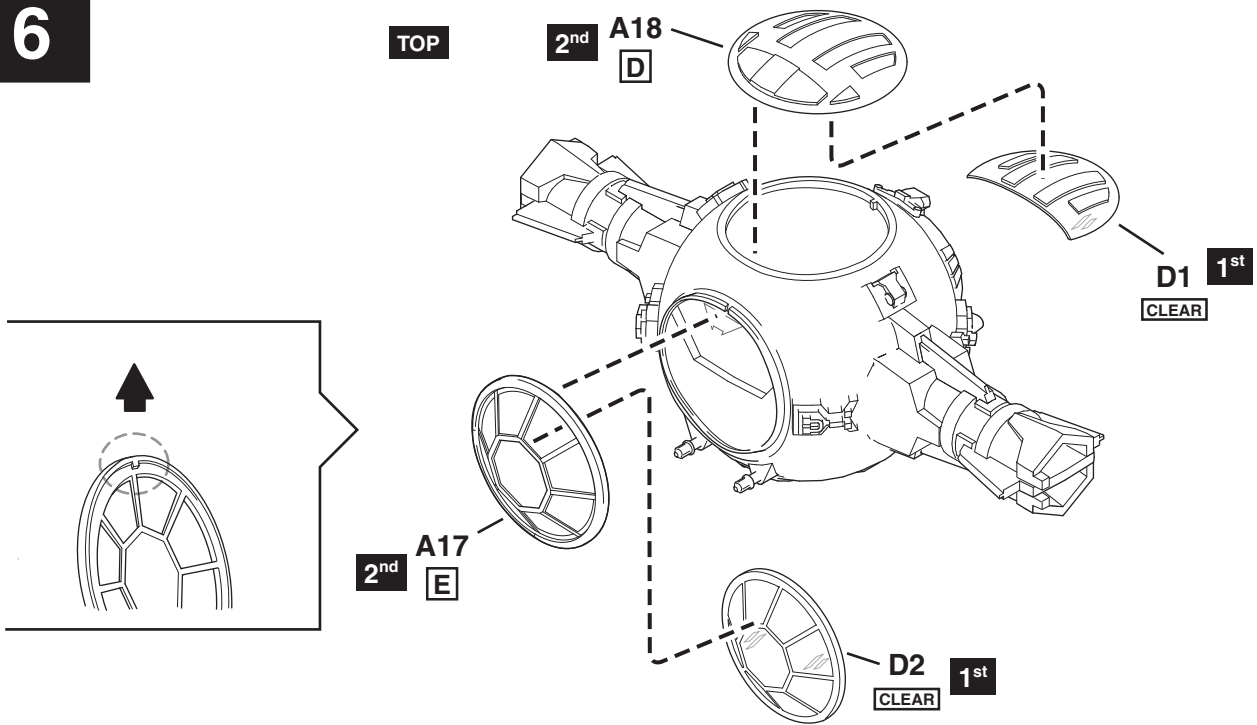

7

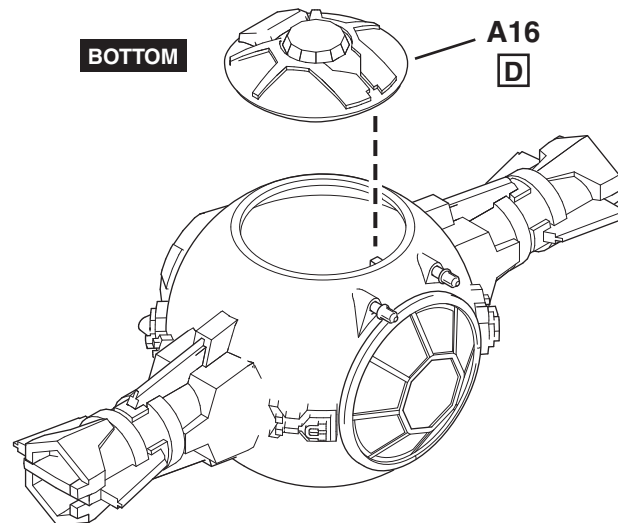



8

2X

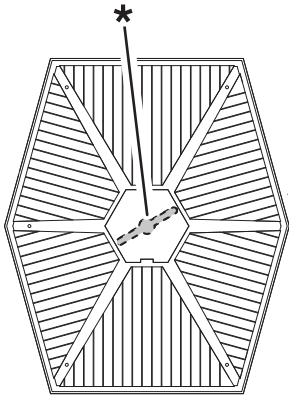

C1

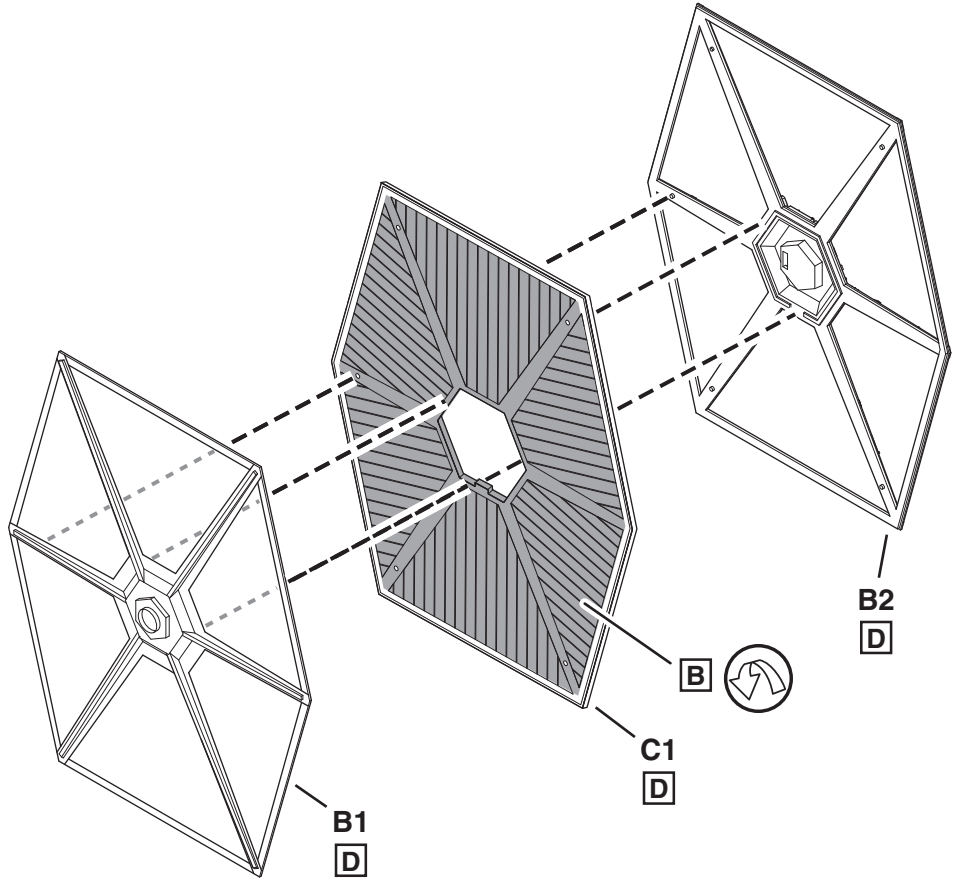

B1  
D

C1  
D

B

B2  
D

9

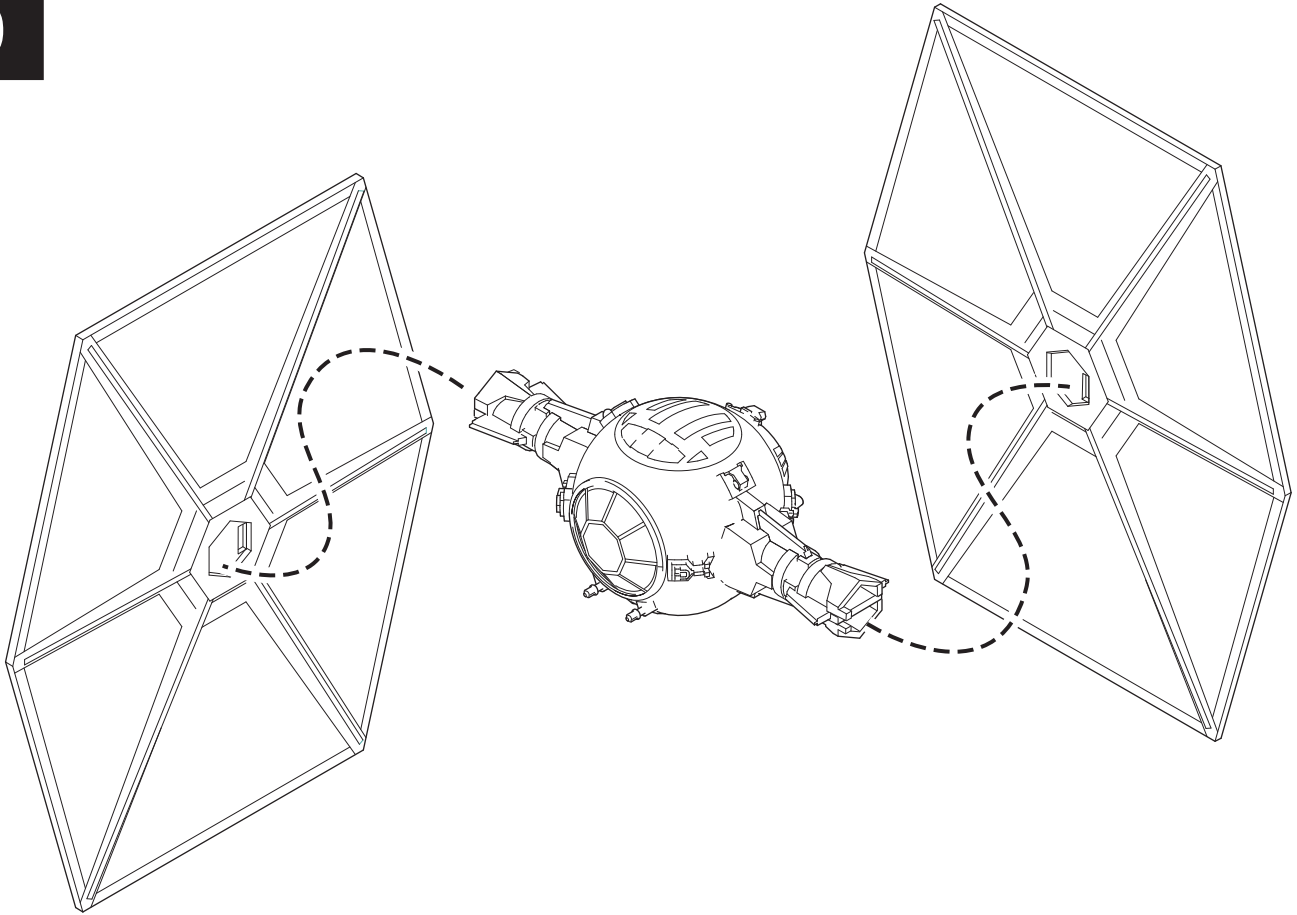

10

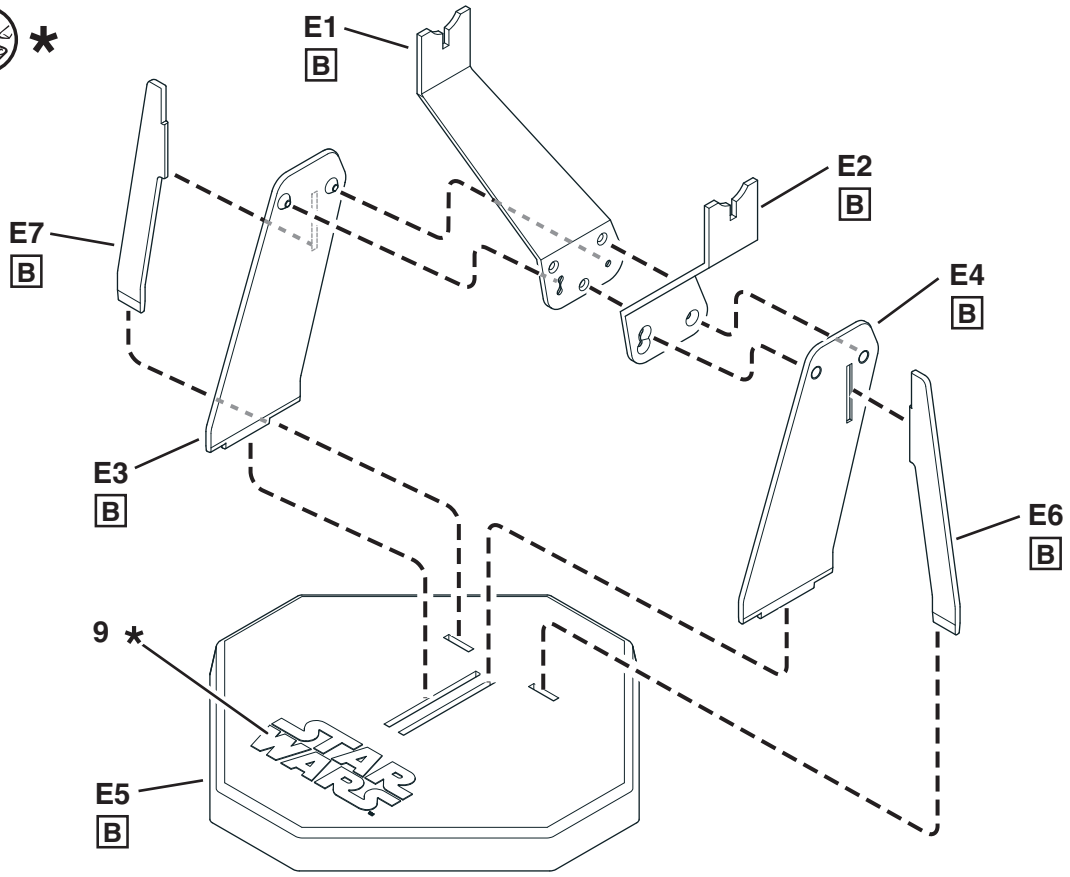

11

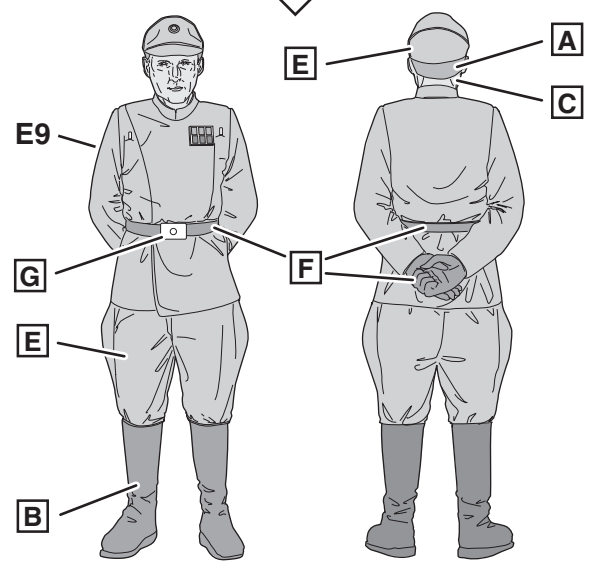
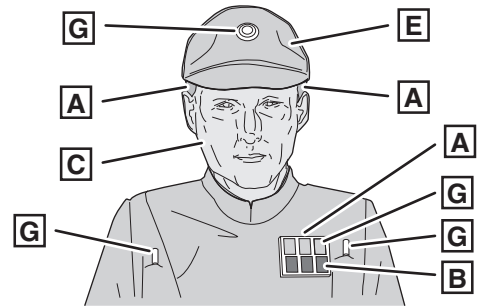
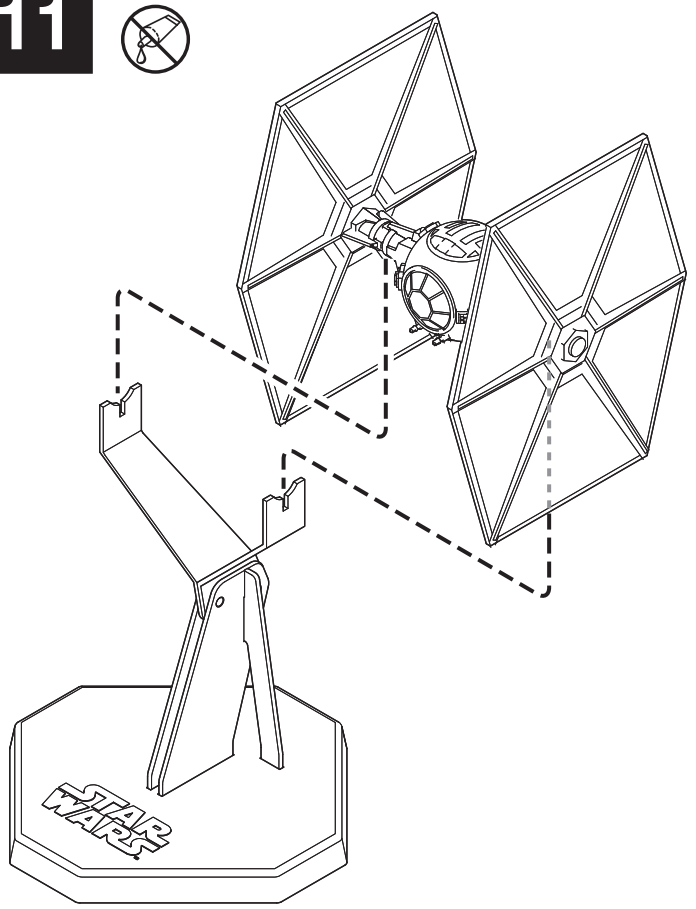

### COCKPIT ACCESS HATCH

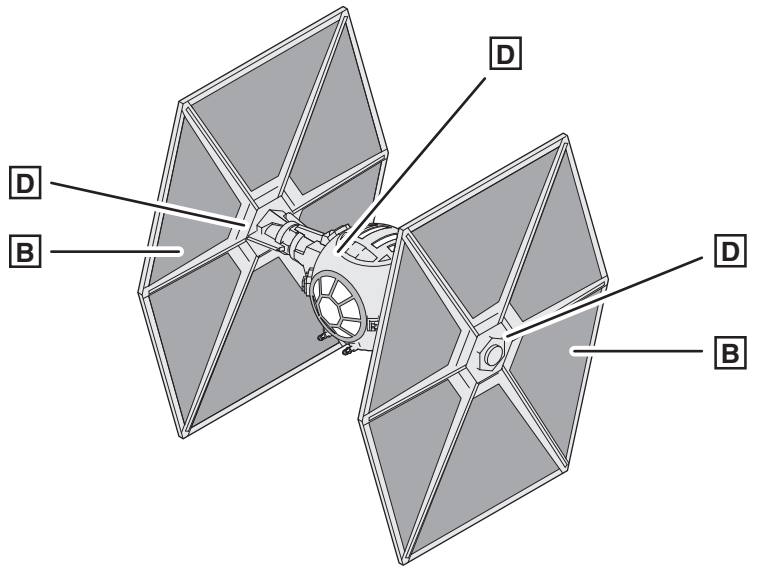
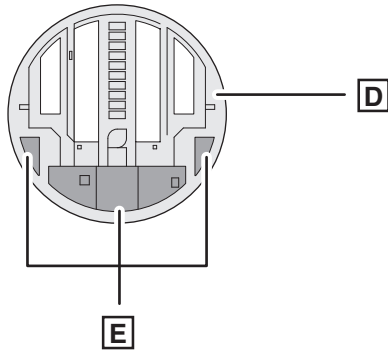

### FRONT

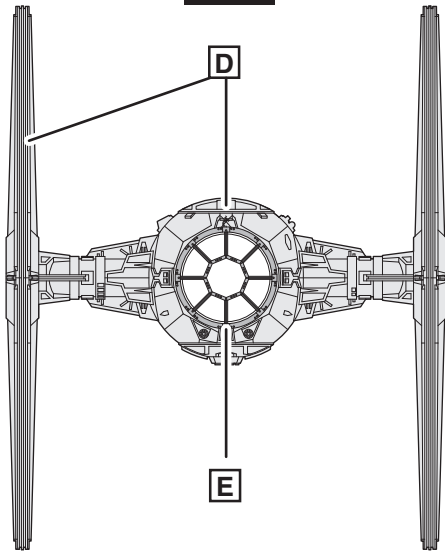

### REAR

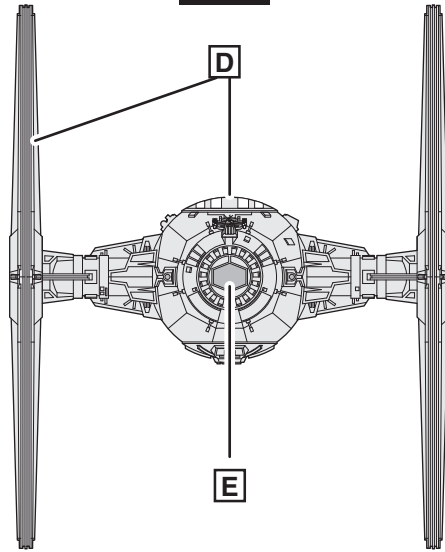

### SOLAR ARRAY OUTSIDE

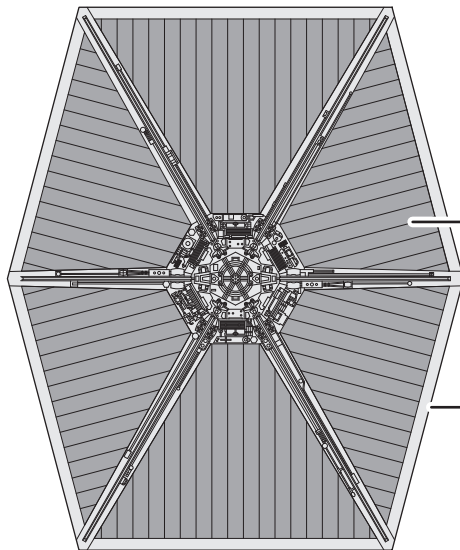

### SOLAR ARRAY INSIDE

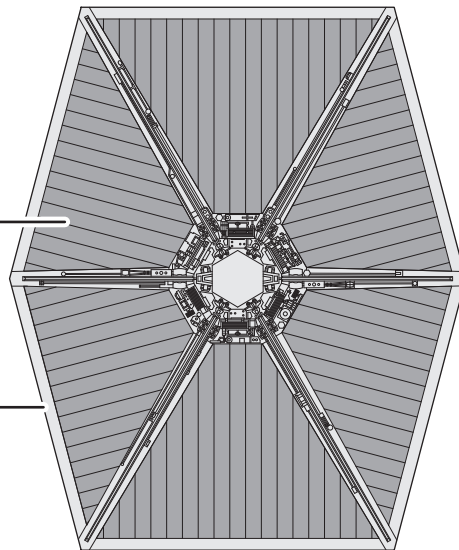



# 13



\*

VERSION 1

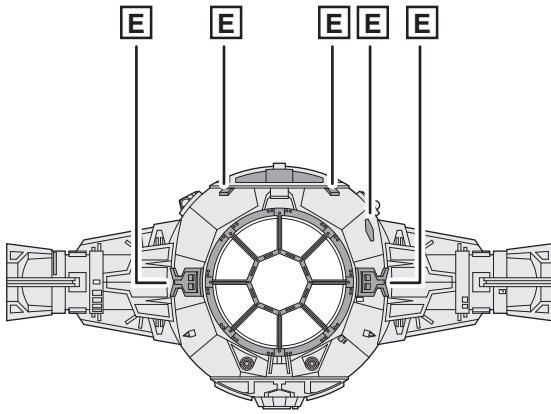

FRONT

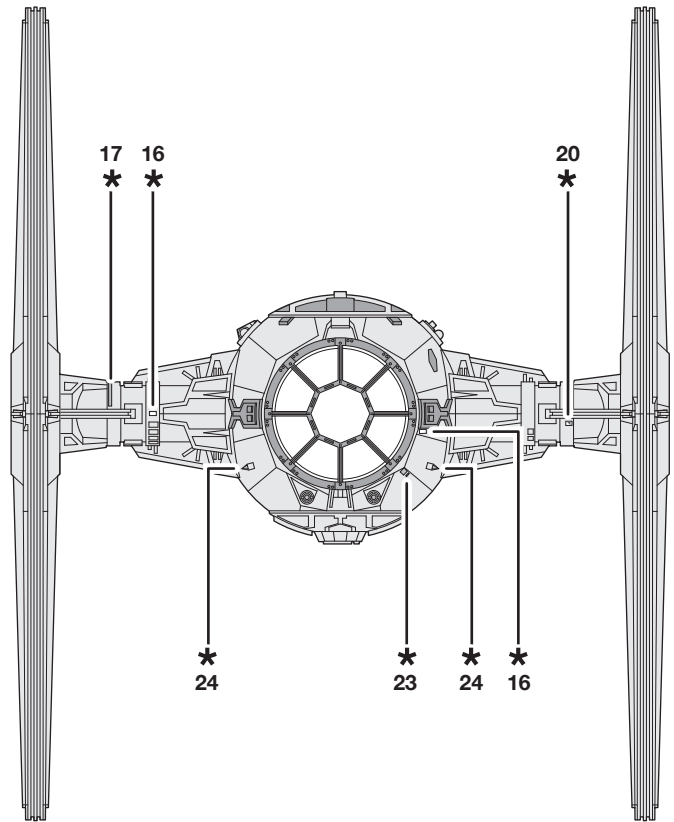

REAR

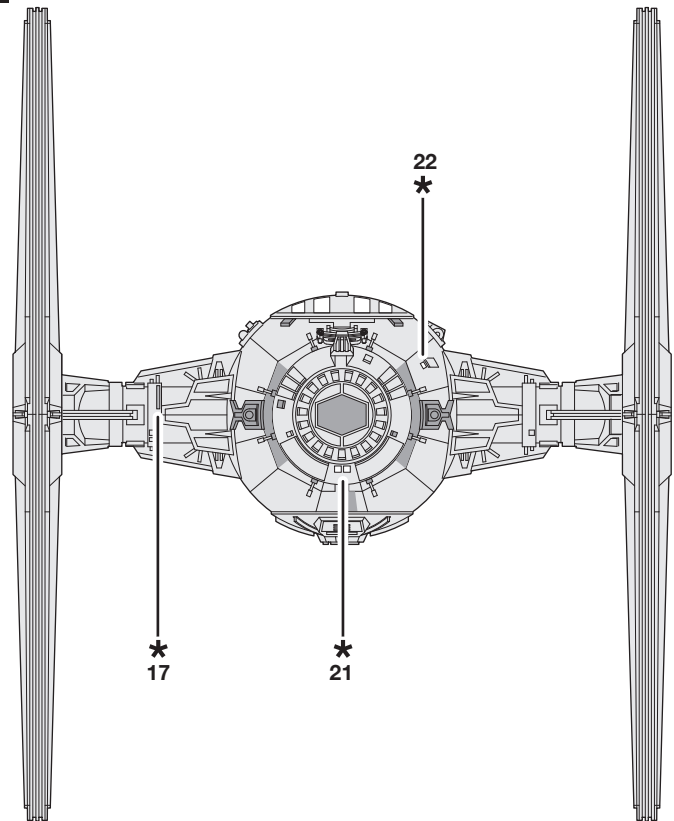
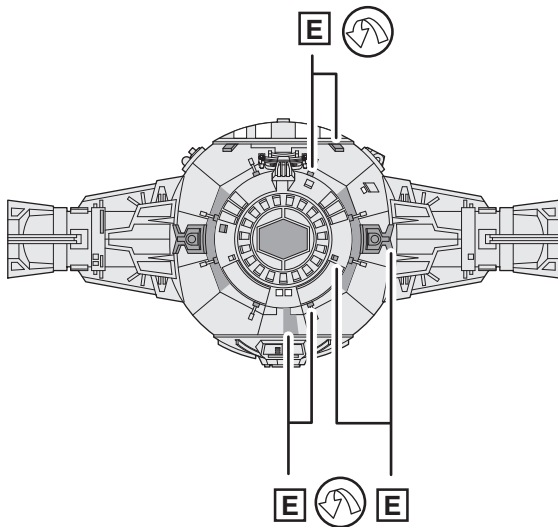

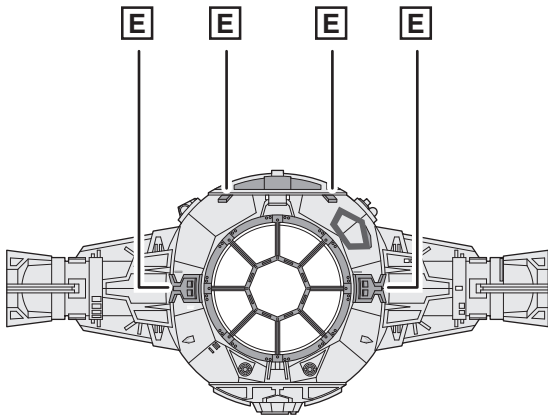

### FRONT

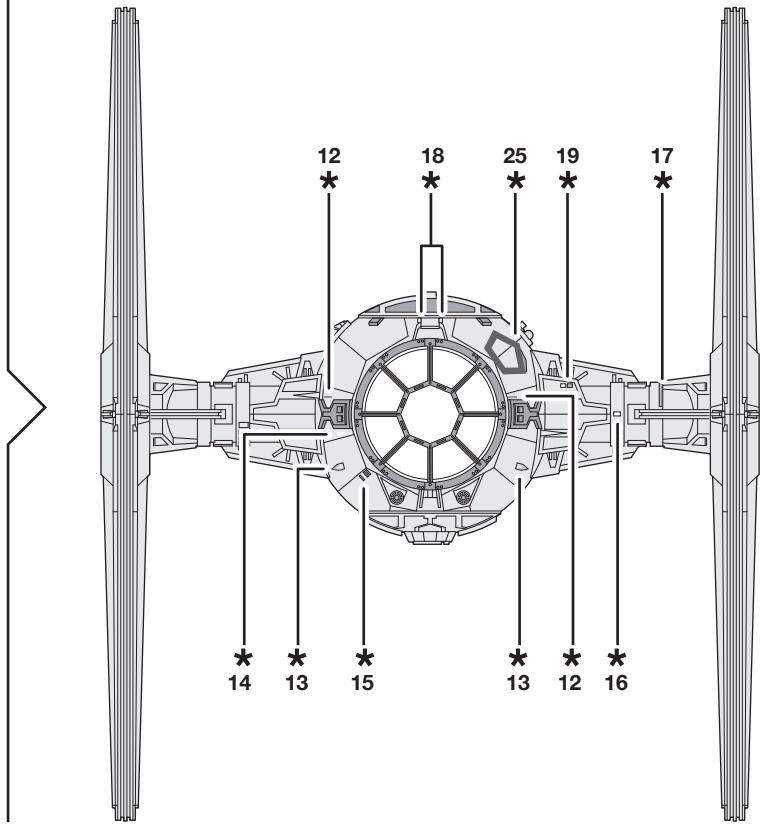

### REAR

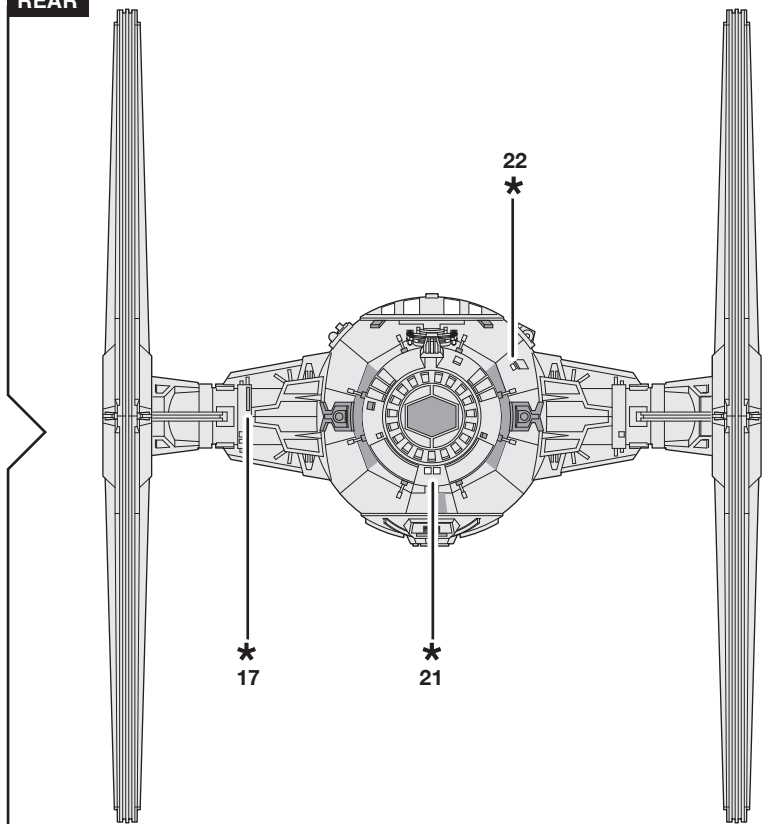
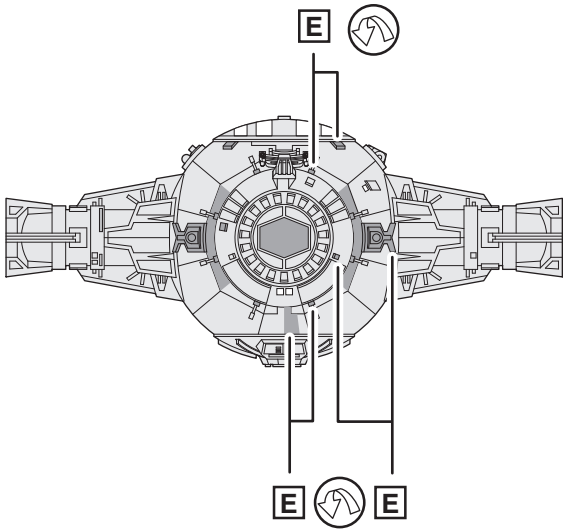

# MASTER SERIES

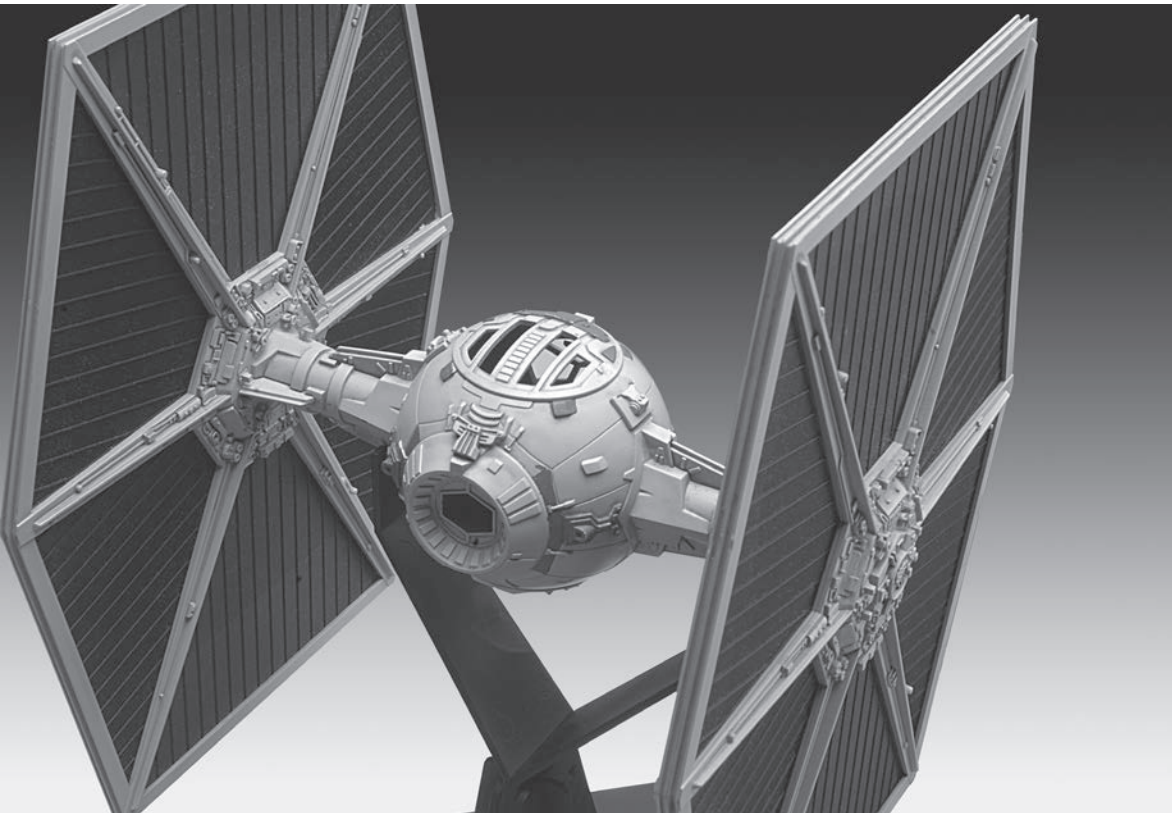
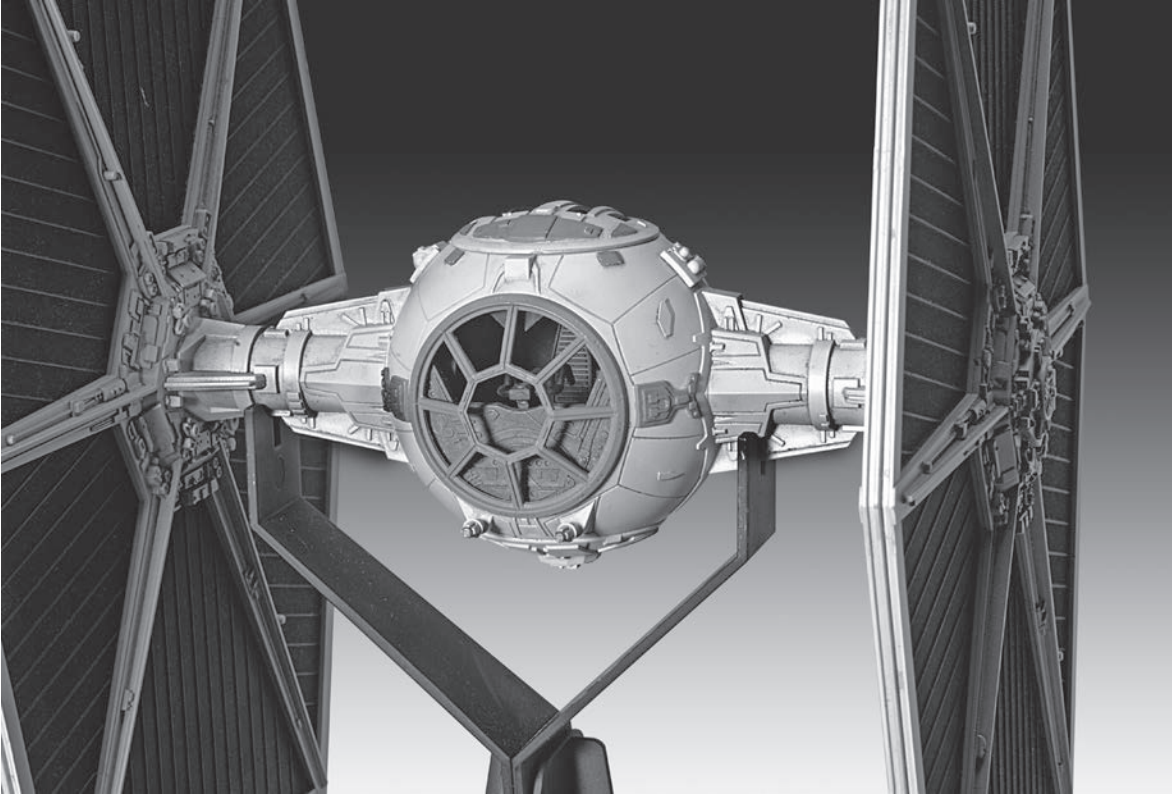

# MASTER SERIES

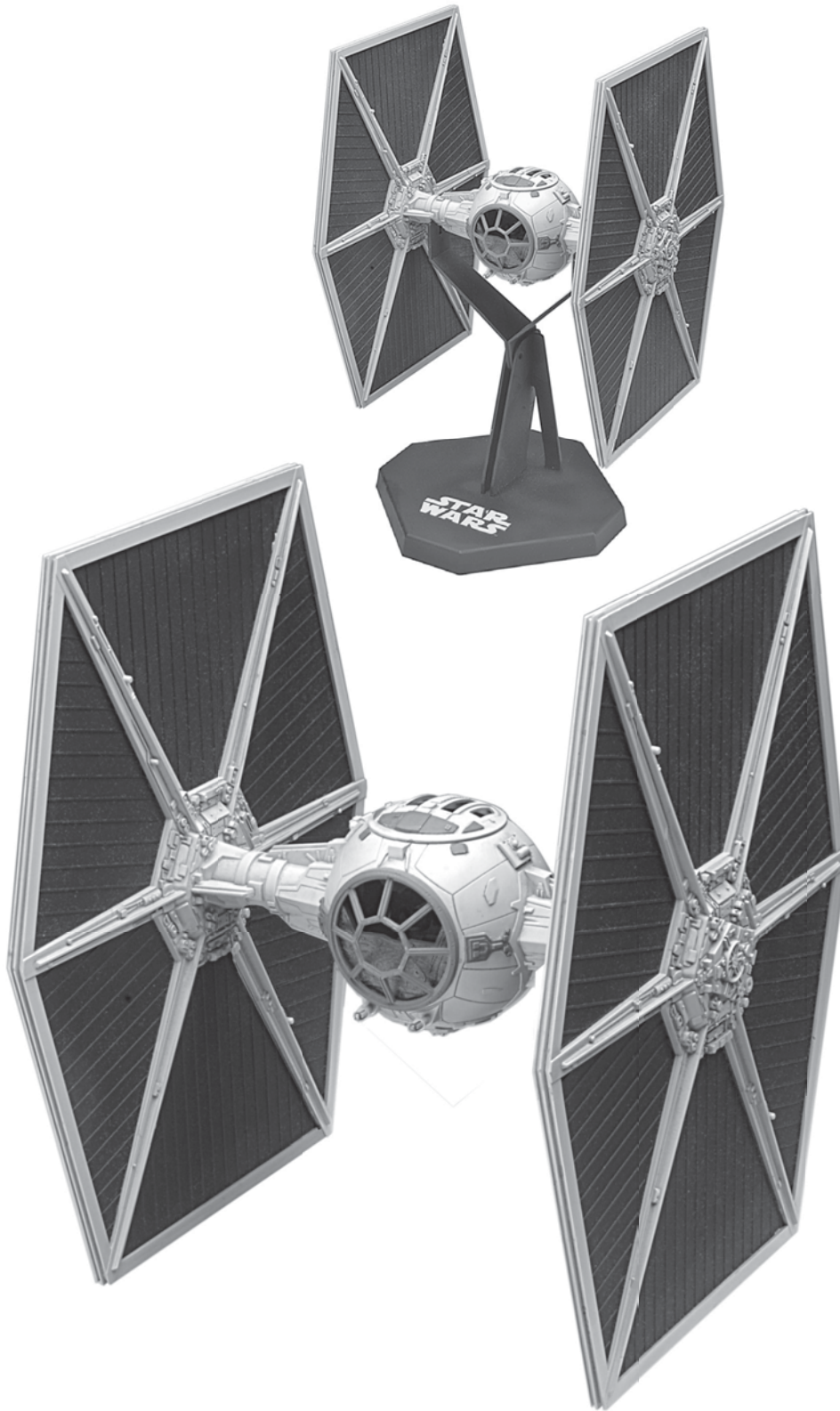

[starwars.com](http://starwars.com)  
© & ™ Lucasfilm Ltd.

All trademarks used under license.  
Toutes les marques de commerce utilisées sous licence.  
Todos las marcas comerciales utilizadas conforme a licencia.