



CAT.No.48-020  
SCALE 1/48

Британський винищувач-бомбардувальник

## De Havilland DH112 Venom

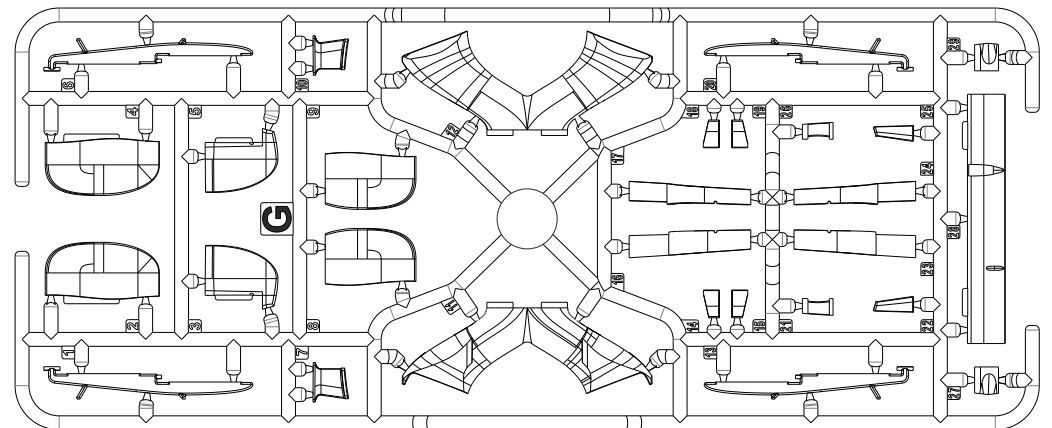
British fighter-bomber aircraft

Де Хевілленд DH.112 "Веном" (англ. de Havilland DH.112 Venom) - британський винищувач-бомбардувальник, розроблений на основі винищувача DH.100 "Вампір". Здійснив перший політ 2 вересня 1949 року. Состояв на озброєнні Королівських ВПС та авіації Королівських ВМС (у модифікації «Сі Веном») у 1952—1962 роках. Поставлявся на експорт до 8 країн світу. Загалом збудовано 1480 машин.

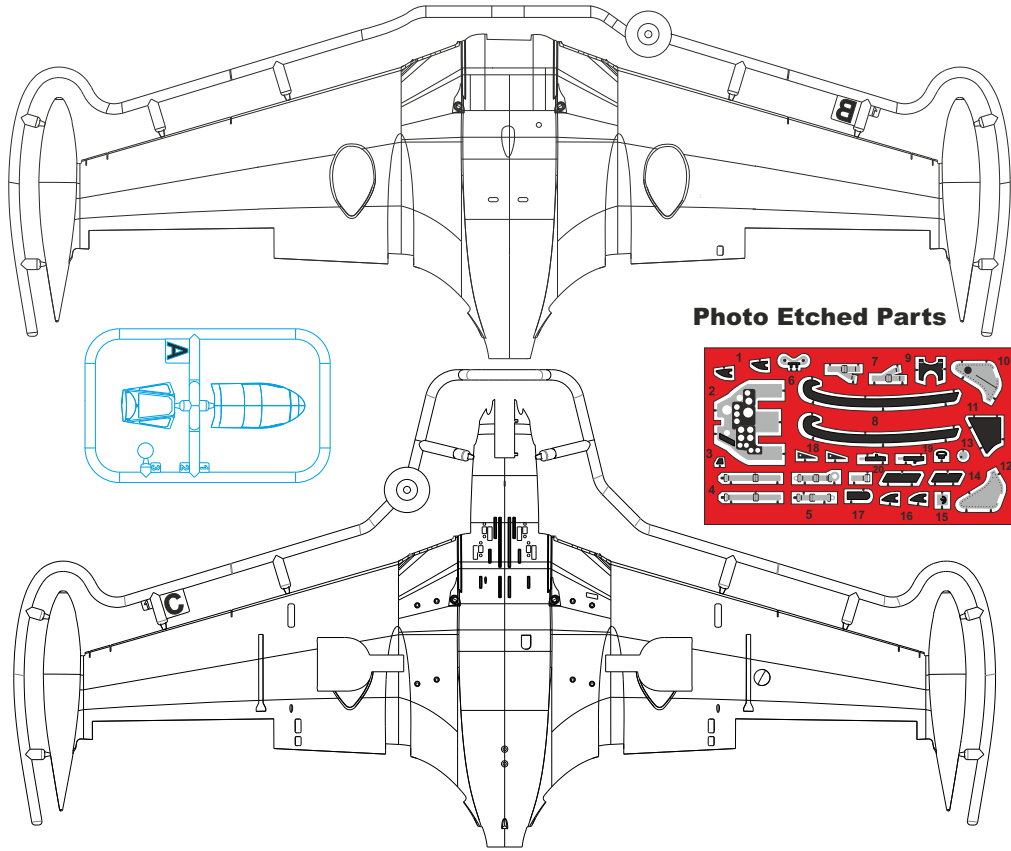
The de Havilland DH 112 Venom is a British post-war single-engined jet aircraft developed and manufactured by the de Havilland Aircraft Company. Much of its design was derived from the de Havilland Vampire, the firm's first jet-powered combat aircraft.

The Venom entered service with the Royal Air Force (RAF), where it was used as a single-seat fighter-bomber and two-seat night fighter. A dedicated model for aerial reconnaissance was also operated by the Swiss Air Force. The Venom functioned as an interim stage between the first generation of British jet fighters – straight-wing aircraft powered by centrifugal flow engines such as the Gloster Meteor and the Vampire – and later swept wing, axial flow-engined combat aircraft, such as the Hawker Hunter and de Havilland Sea Vixen. Accordingly, the type had a relatively short service life in the RAF, being withdrawn from frontline operations by the service in 1962 as a result of the introduction of more capable designs. However, it was used in combat during the Suez Crisis, the Malayan Emergency, and the Aden Emergency.

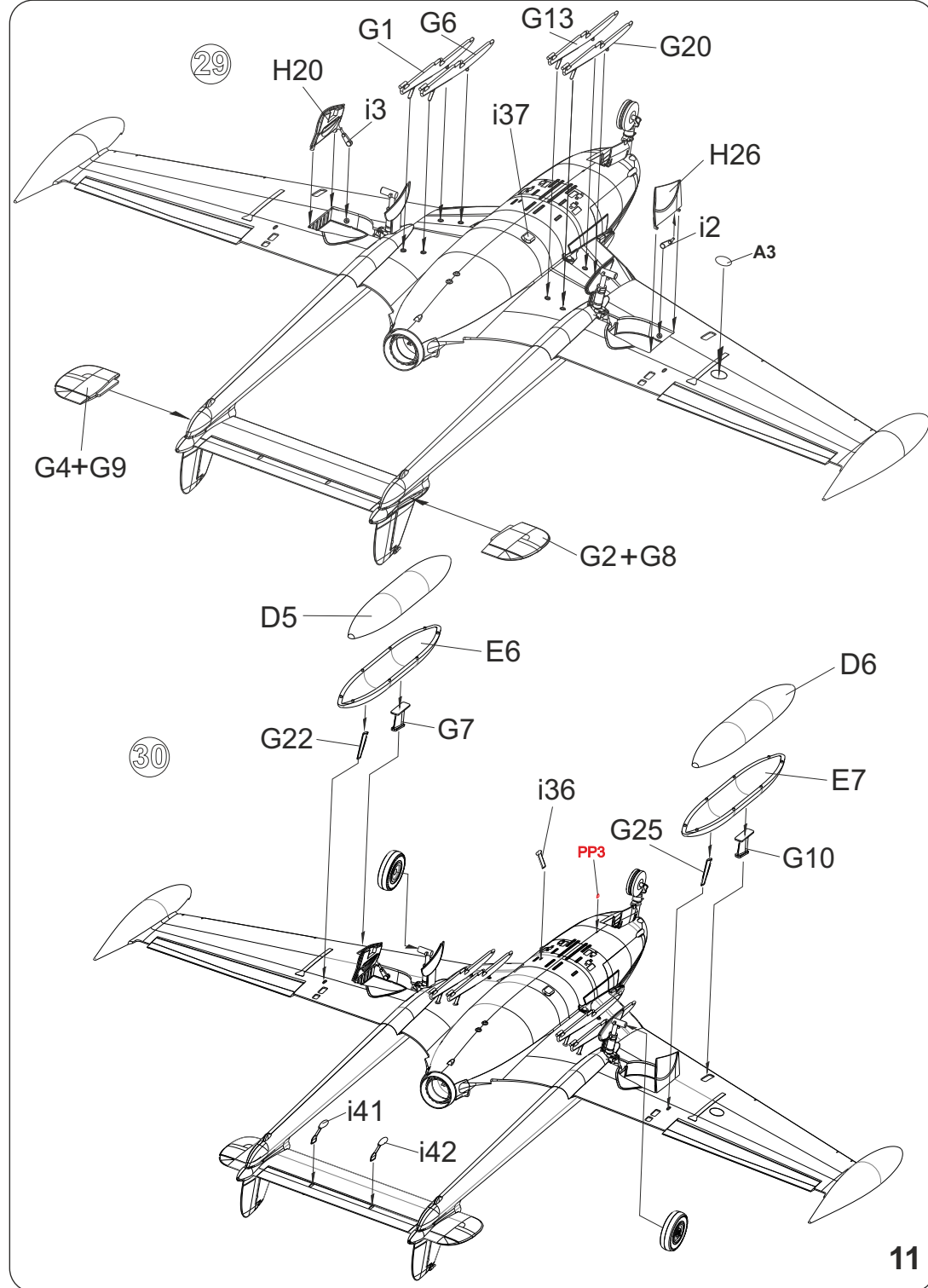
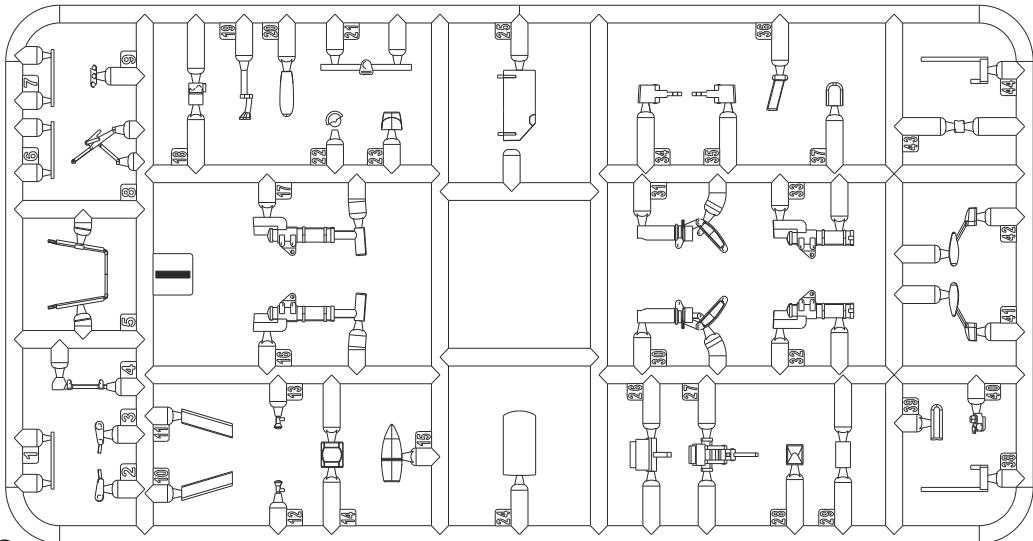
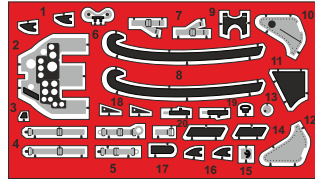
The Venom proved to be popular on the export market, being sold in substantial numbers to Iraq, New Zealand, Sweden, Switzerland and Venezuela. The Swiss Air Force was the last active military operator of the Venom, retiring their last examples during 1983. Large numbers of ex-military Venoms have since been acquired by private entities and several have continued to fly, performing aerial displays at various air shows, while many examples have been preserved in static display conditions in museums and as gate guardians. A specialised derivative, the Sea Venom, was produced as a navalised version of the aircraft suitable for carrier operations.

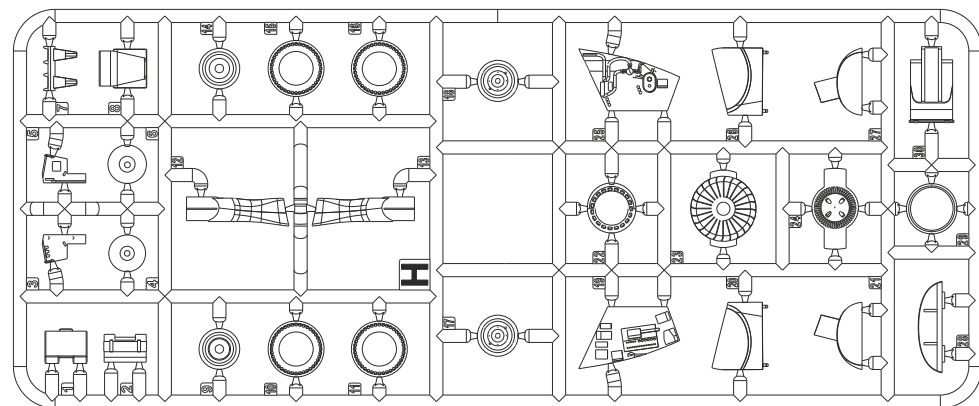
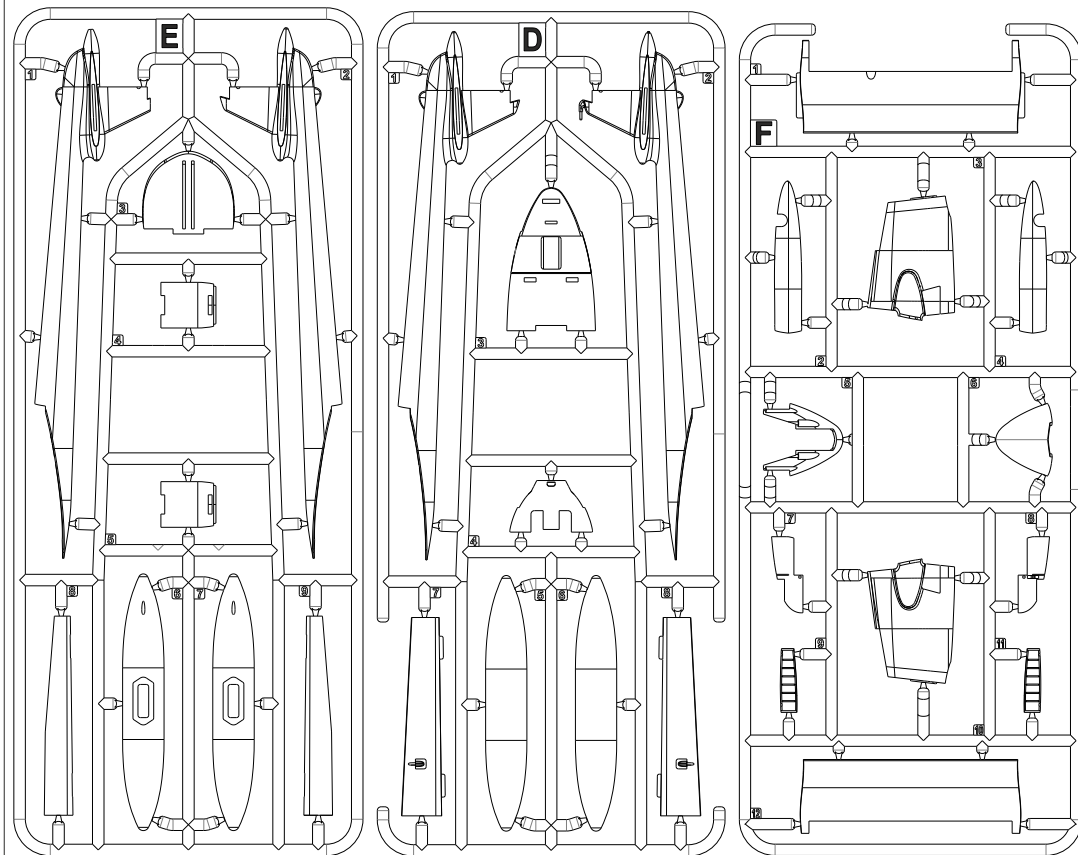
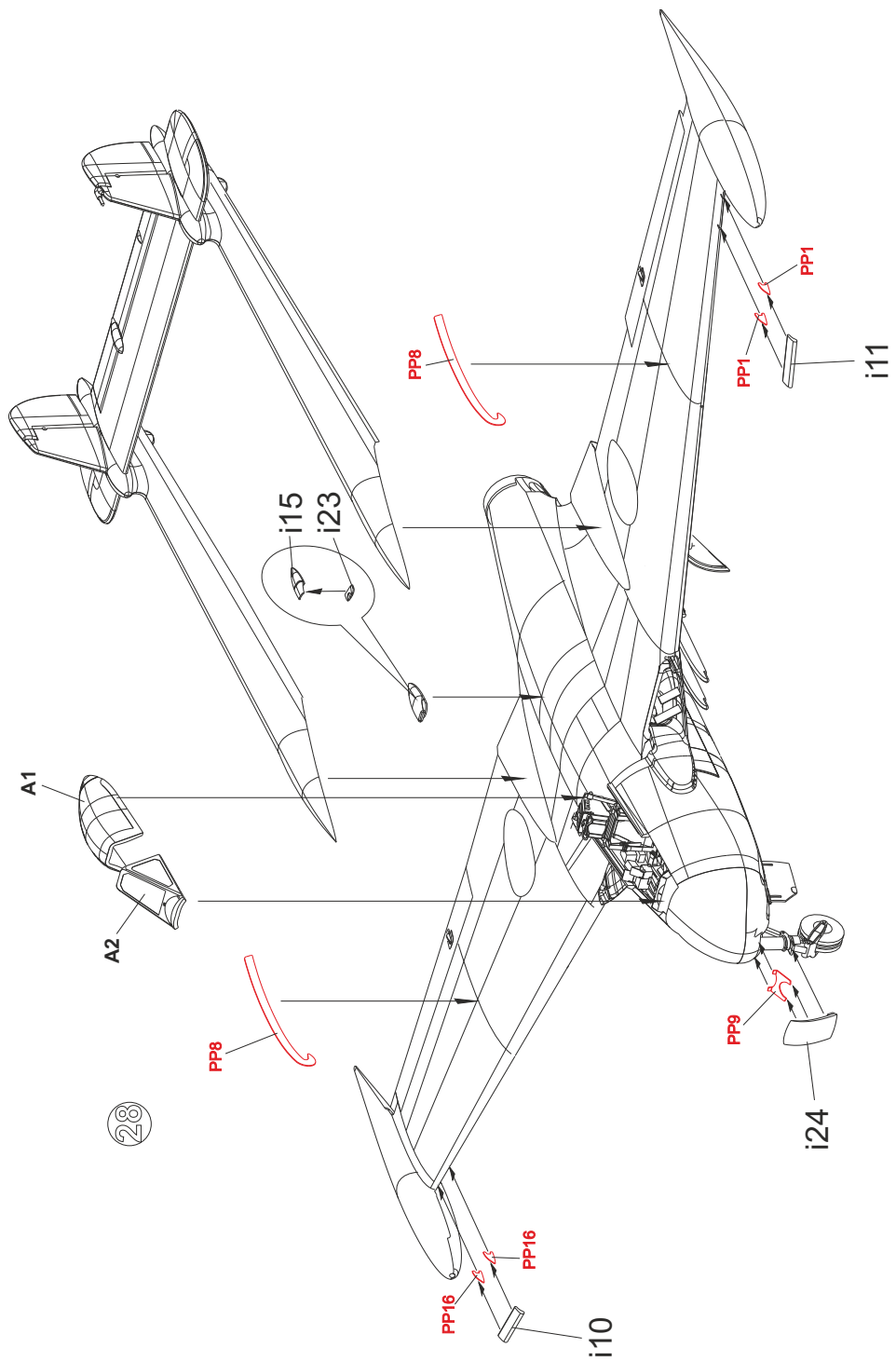


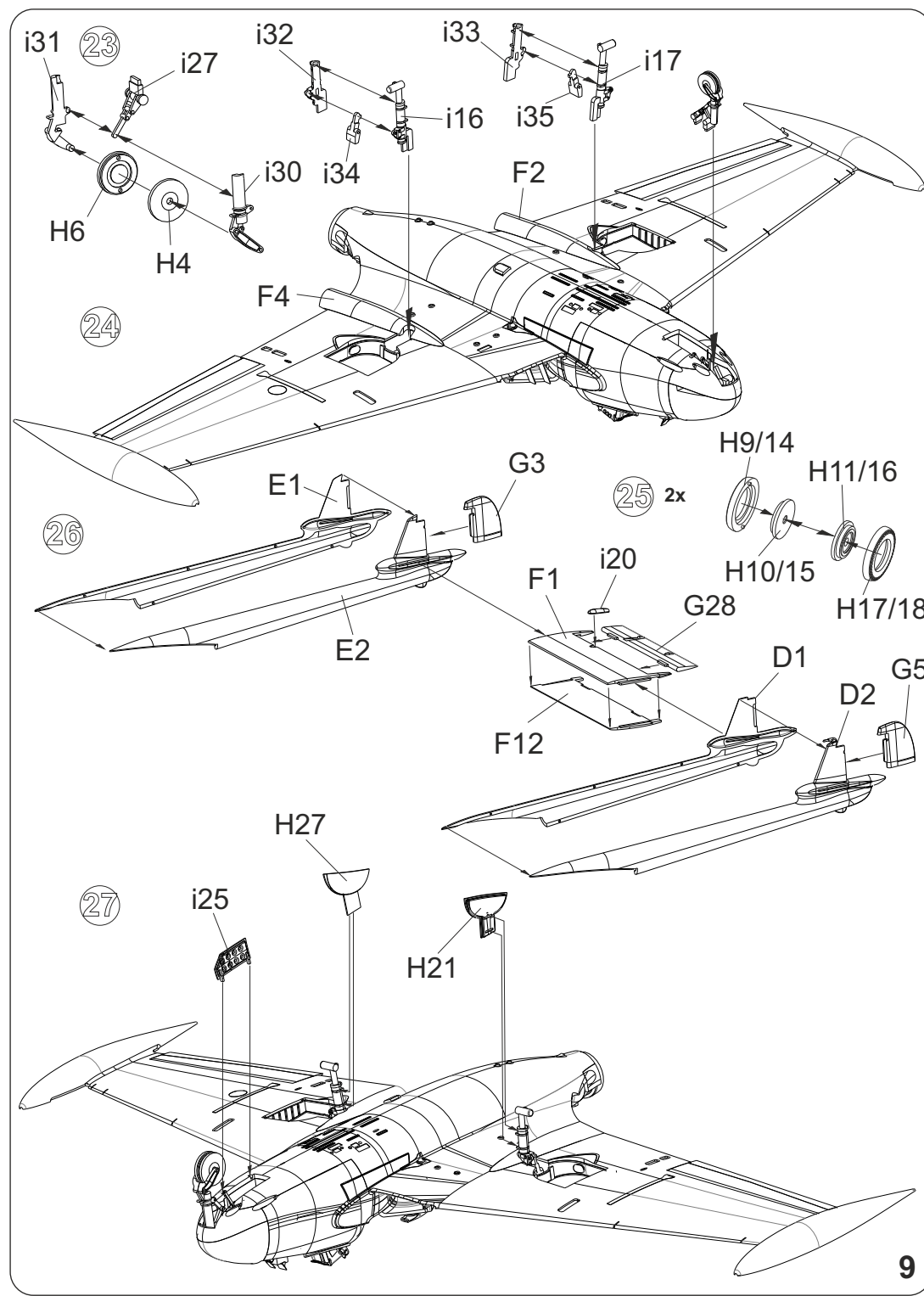
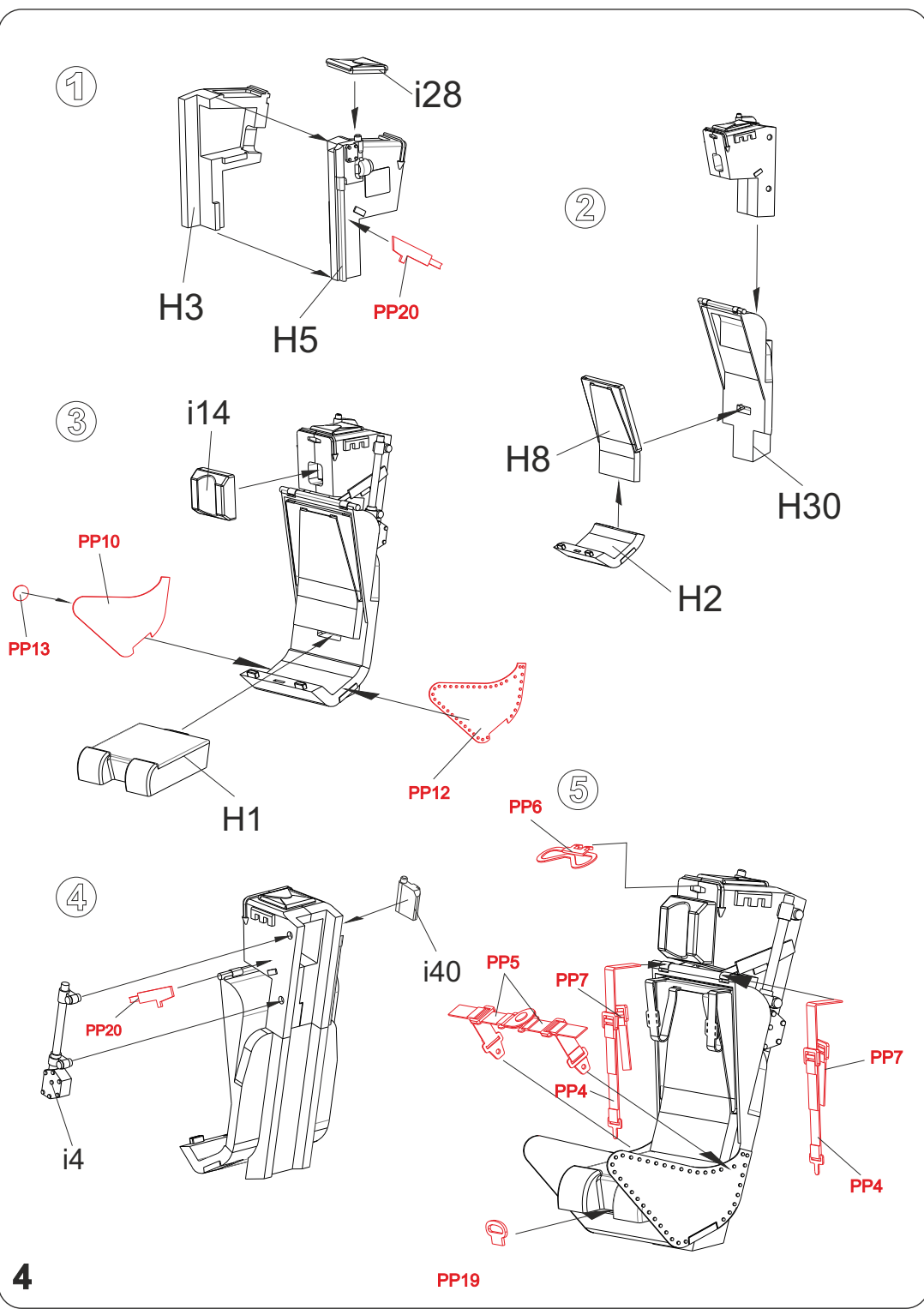
**Деталі моделі Part of the model**

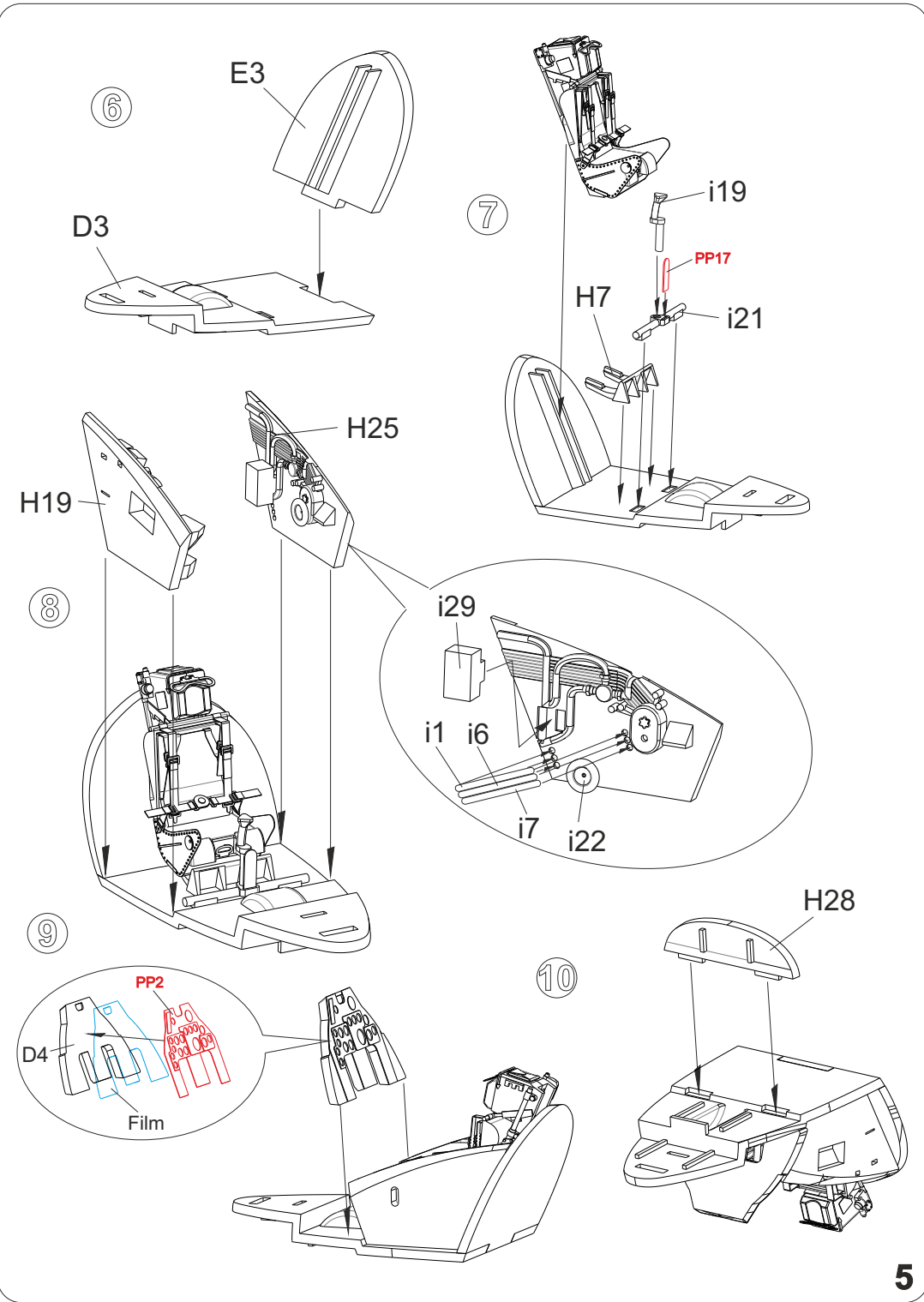
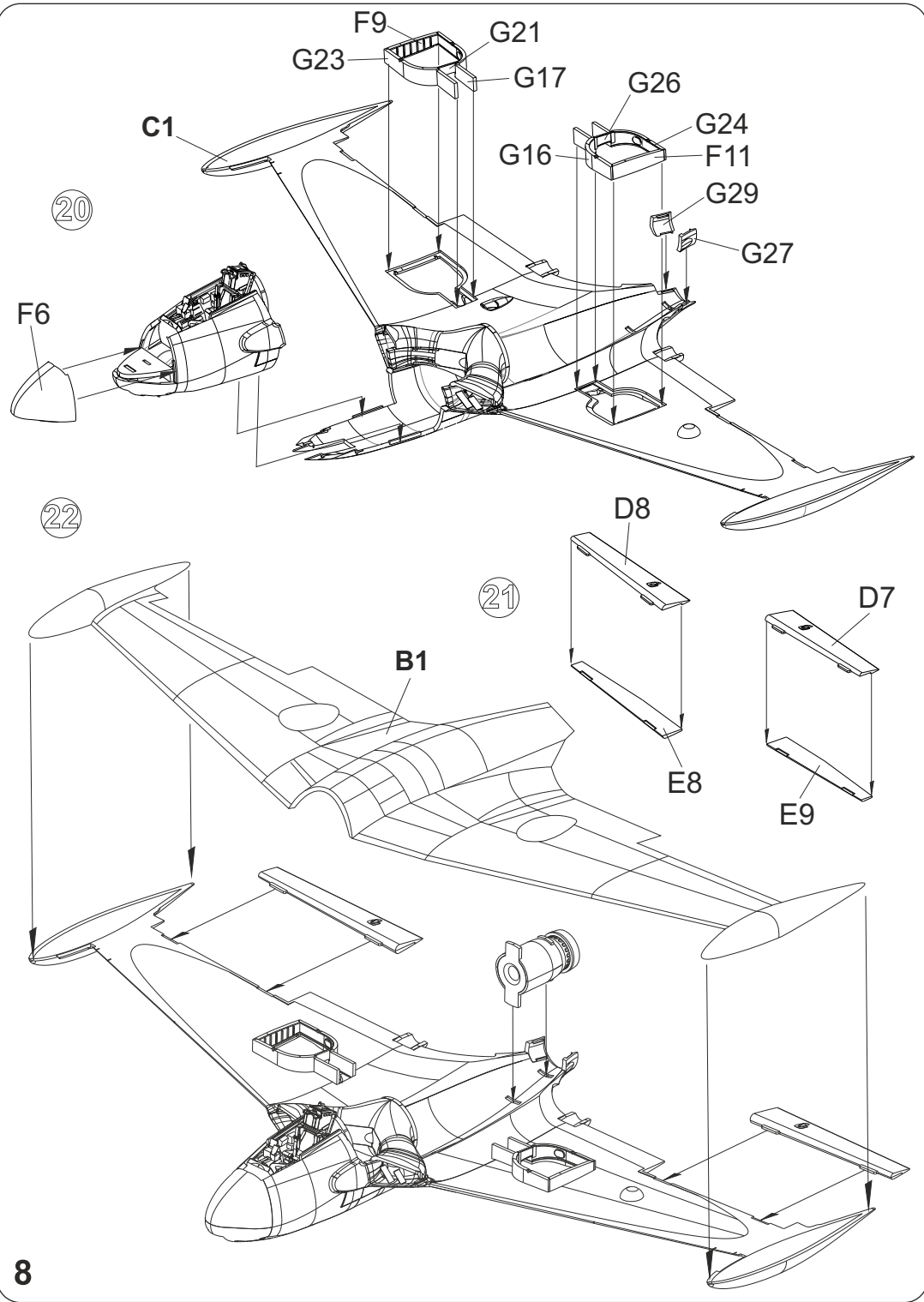


**Photo Etched Parts**



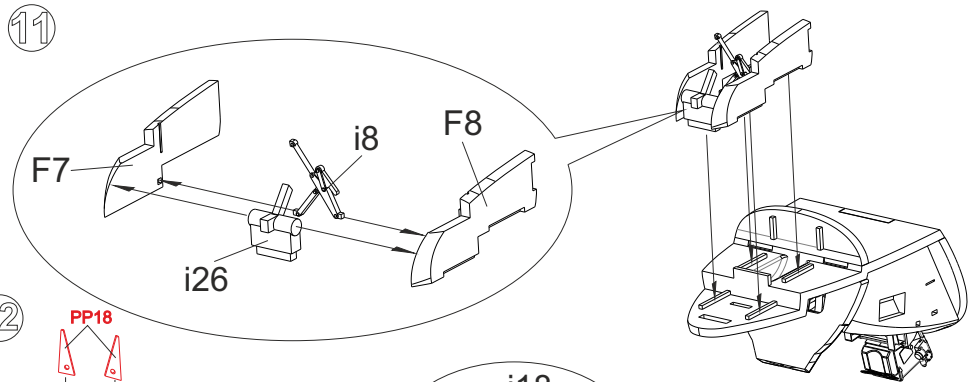




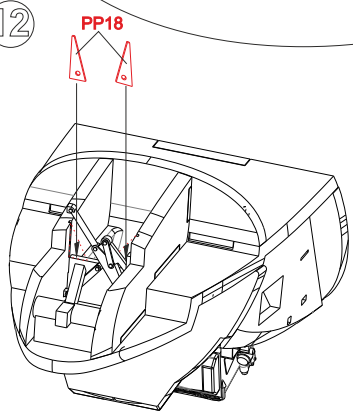




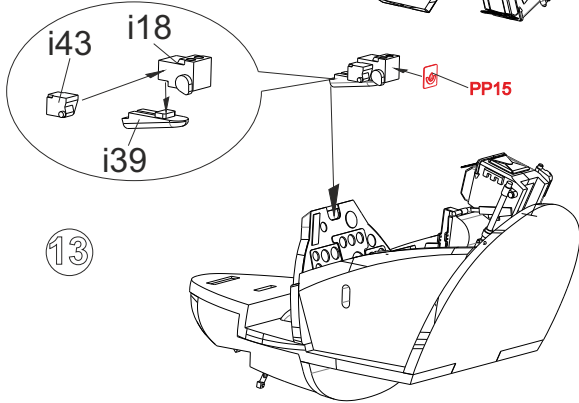
11



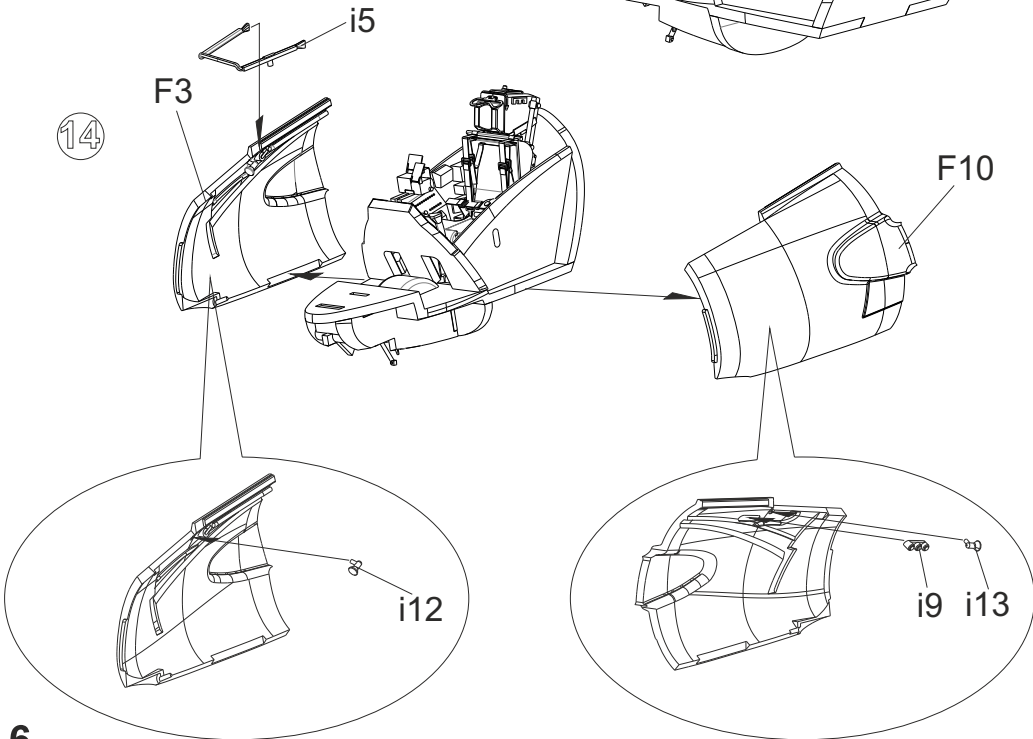
12



13

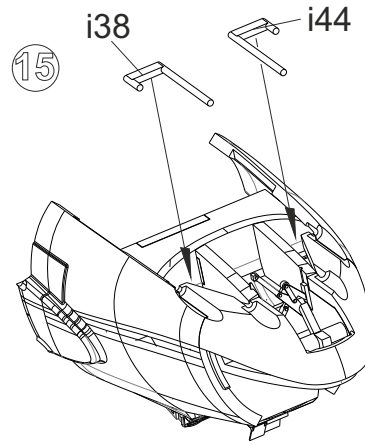


14

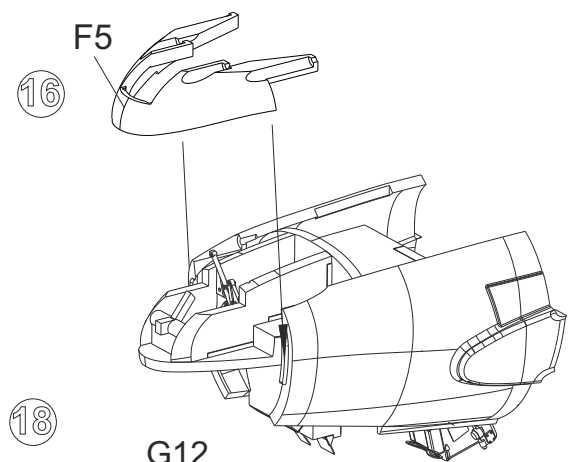


6

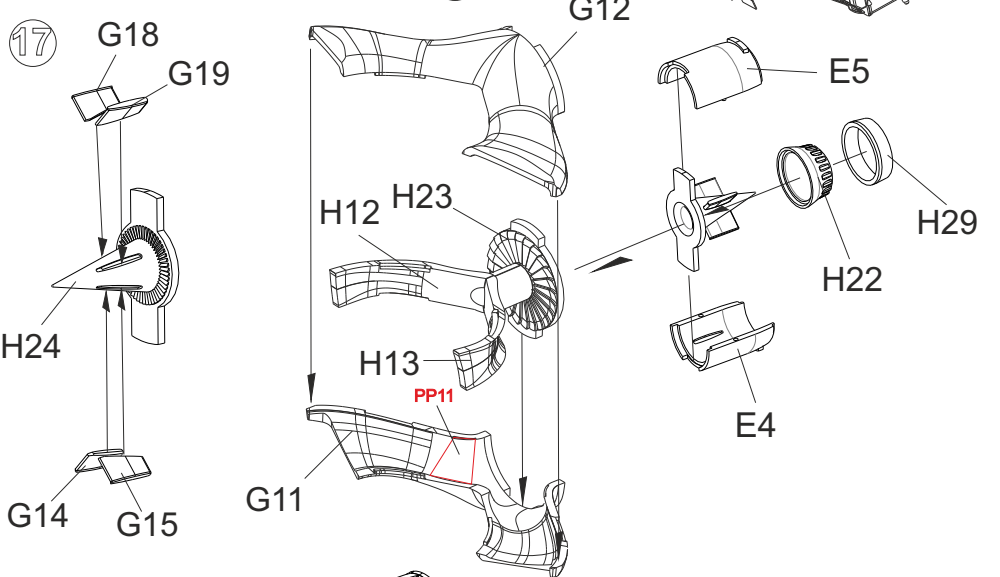
15



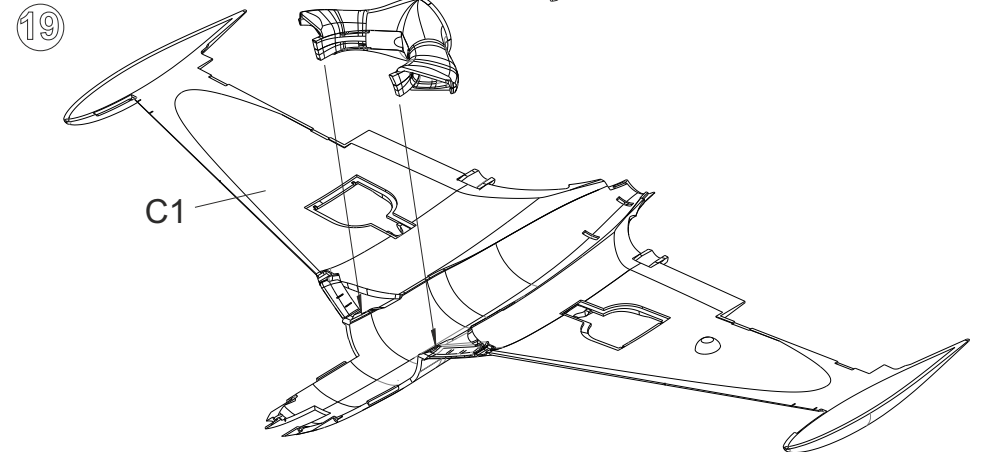
16



18

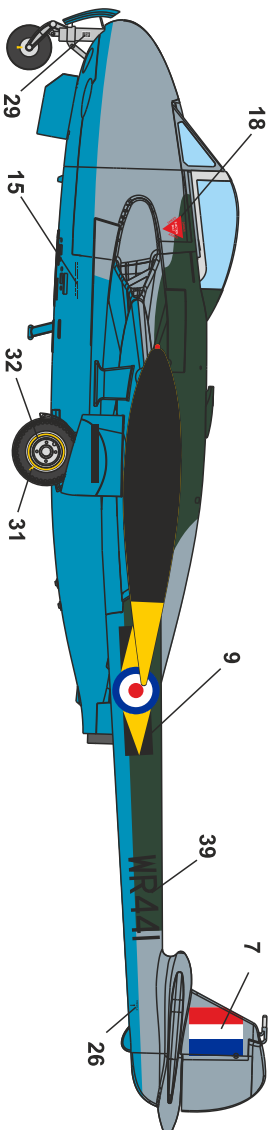


19

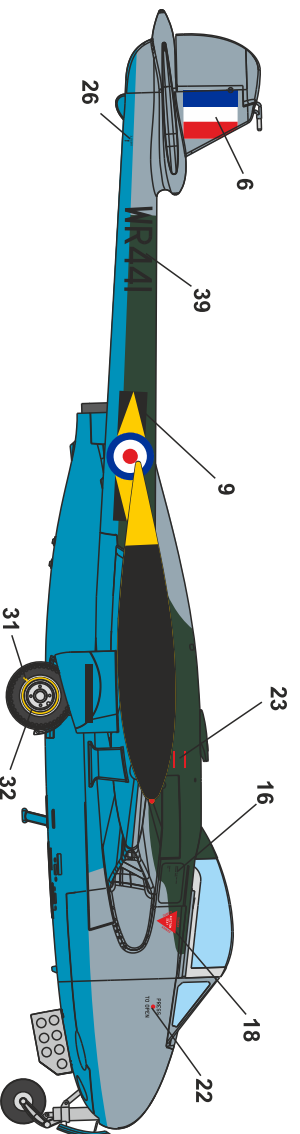
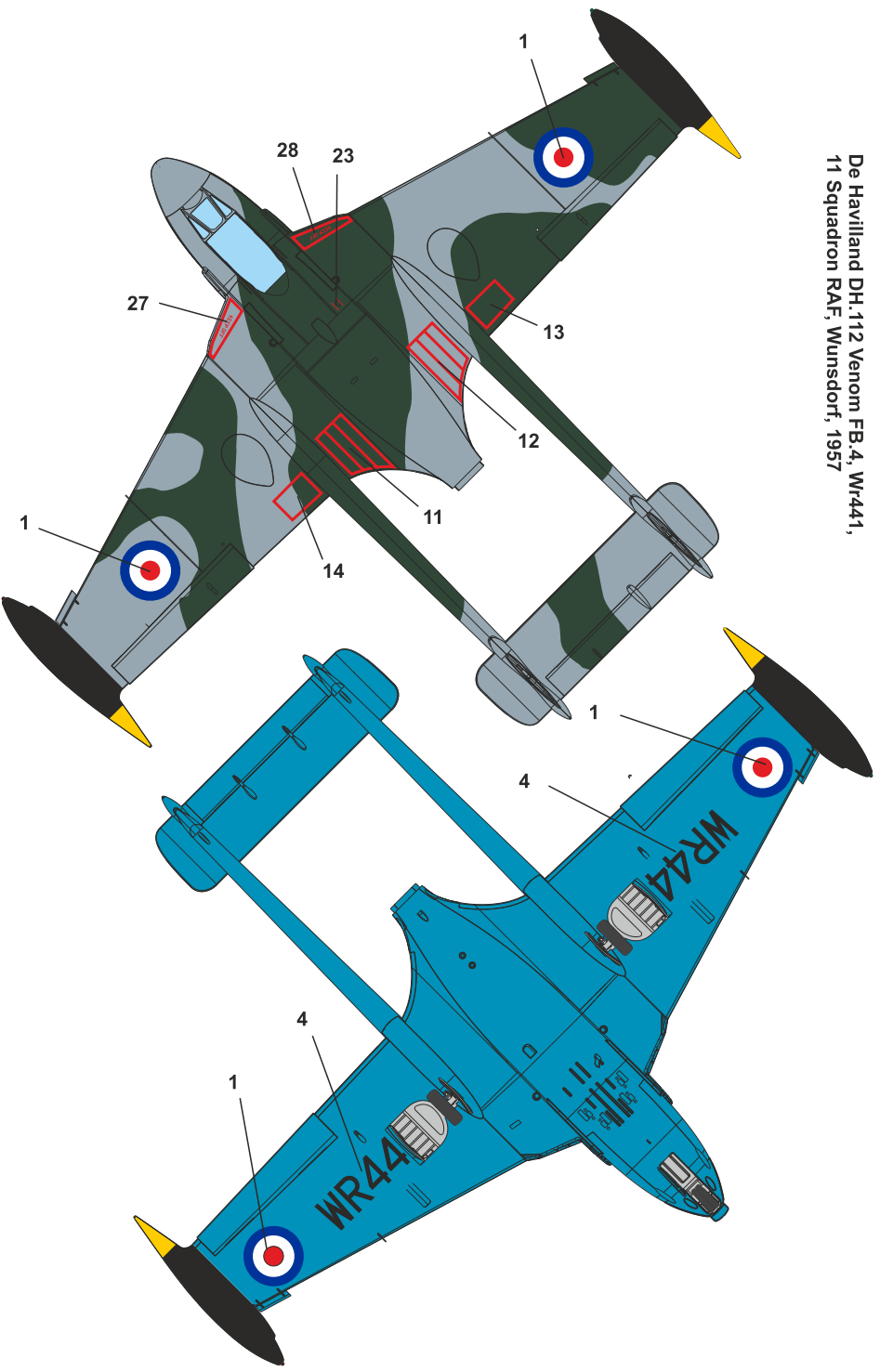


7

Нанесення декалей та фарбування  
(Application decals and paints)



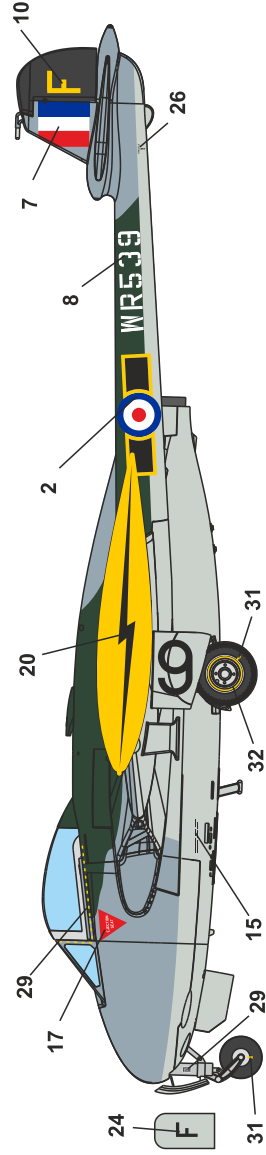
De Havilland DH.112 Venom FB.4, W1441,  
11 Squadron RAF, Wunsdorf, 1957



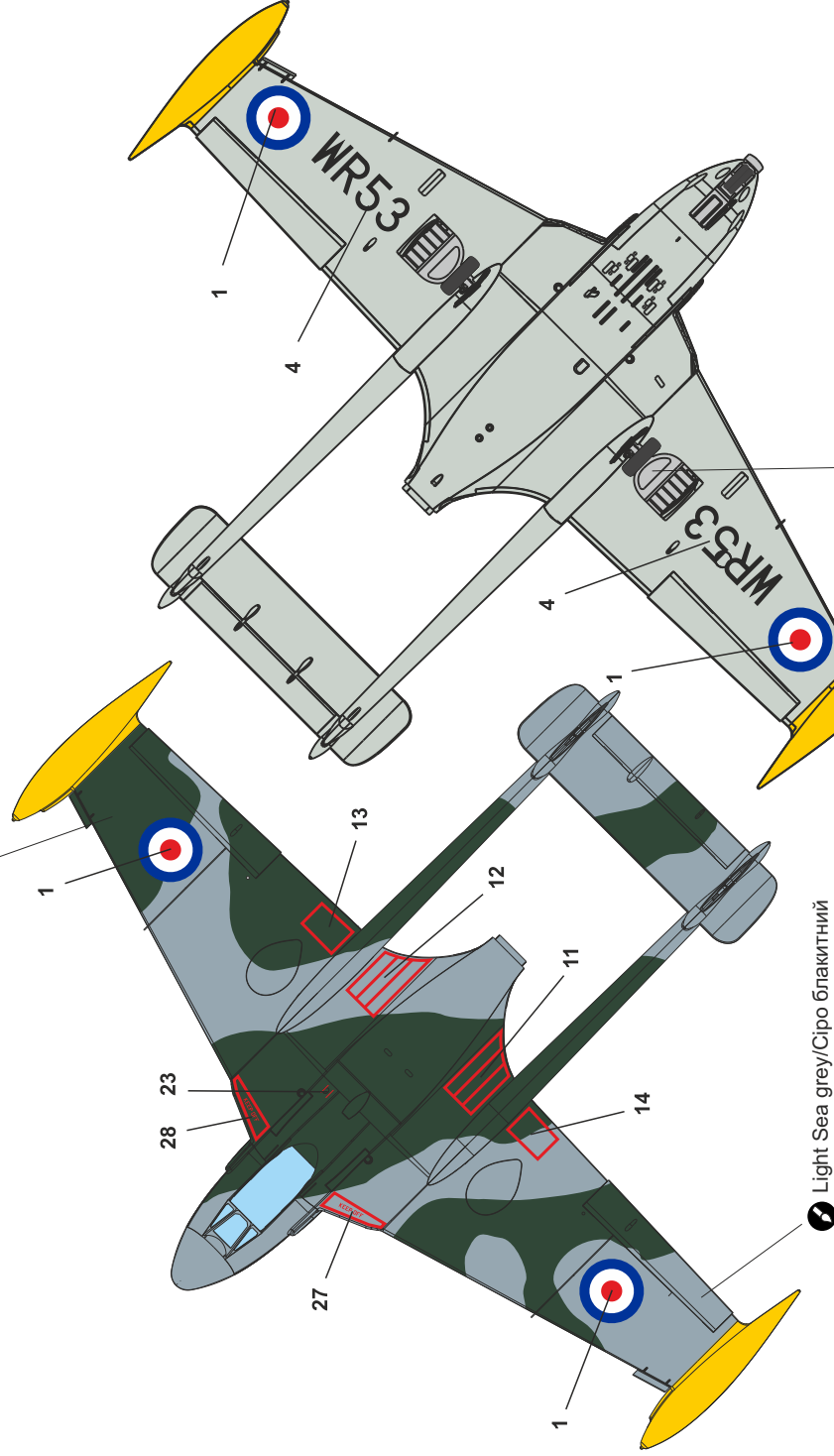
E-mail: [info@mikro-nlr.com](mailto:info@mikro-nlr.com)  
[mikronlr.dnepr@gmail.com](mailto:mikronlr.dnepr@gmail.com)  
[www.mikro-nlr.com](http://www.mikro-nlr.com)

Made in Ukraine

Нанесення декалей та фарбування  
(Application decals and paints)



Темно зелений (Dark green)

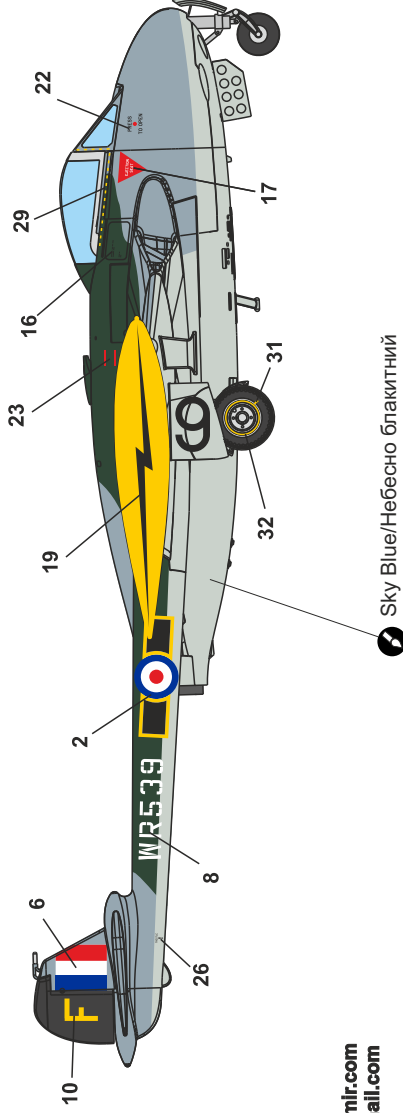


Light Sea grey/Сіро блакитний

Light grey/Світло сірий

Yellow/Жовтий

De Havilland DH.112 Venom Fb4, WR 536,  
28 Squadron RAF, Hong Kong Kai-Tak, 1963



Sky Blue/Небесно блакитний