

FALCON CORRIDORS

For DeAgostini Kit ISSUES 23-28

**PARA
GRAFIX™**
PGX197

ParaGrafix states that our use of the trademarked terms listed below in our product descriptions constitutes fair use and nominative use and is in no way to offer confusion that ParaGrafix and any of the following noted trademark holders are related companies, nor do we state that we are endorsed by these trademark holders. We are an AFTERMARKET company acting in GOOD FAITH in providing high quality products to loyal customers who have already purchased products related to these trademarks. ParaGrafix is actually providing these trademark holders a venue of free advertising and indirectly provide these trademark holders with more sales leads.
© & TM 2015 Lucasfilm LTD. © & TM DeAgostini Publishing USA Inc., DeAgostini Editore S.p.A.

INTRODUCTION

Thank you for purchasing ParaGrafix's corridor upgrade set for the Millennium Falcon subscription kit from DeAgostini Publishing. This set is intended for modelers of moderate experience who are handy at modifying existing kit parts.

Please note that these instructions replace some of the kit's instructions for assembling the hold. It is suggested that you familiarize yourself with all aspects of the hold assembly before proceeding.

Materials

In addition to the photoetch, you will also need scissors or a knife* to remove individual pieces from the main fret, a file to remove material left from cutting, and super glue (aka CA or cyanoacrylate). Additionally, to fold some pieces, you will need a pair of razor blades** or a specialty tool such as PhotoFold from ParaGrafix.

* We prefer a #17 Xacto chisel blade in combination with a glass cutting board or other, similarly hard cutting surface.

** Extreme care must be taken when using razor blades. Risk of serious injury.

Installation Parts Order

The installation steps are not in any particular order. You can complete them as you see fit to complement your kit construction order.

Decals

Please see JT Graphics' specific instructions for the use of the decals in conjunction with this set.

Key

Kit part (plastic):



Photoetched part:



Decal:



Lighting the Floor Grates

If you are planning to light floor grates, then you will need to do some surgery to the kit pieces. Repeat this procedure for all three sections of flooring (main corridor, cockpit corridor, and the hold extension).

Cut out the areas shown on both sides of the corridor.

The cockpit corridor floor section is shown, but it's the same technique for all three sections.

Note that you need to leave the area around the "triangle" cutouts for mounting the padded rings. Also leave a bit of material a shade wider than the opening in the photoetch to provide some support for the metal as the holes make it weaker in this area.

The easiest way to add lighting is with LED strip light, such as ParaGrafix' Easy LED. Warm white strips will simulate the incandescent lighting used on the sets and the amount of light can be varied by either using standard density (PGX158-0.6) or high density (PLD-WW-HD-0.6) tape. Attach the strip to either the underside of the deck or the top of the surrounding tube as shown at left. (Attaching to the tube is suggested as this will make handling easier.)

Standard Density:

http://www.paragrafix.biz/product_detail.asp?PPartNum=PGX158-0.6



High Density:

http://www.paragrafix.biz/product_detail.asp?PPartNum=PLD-WW-HD-0.6

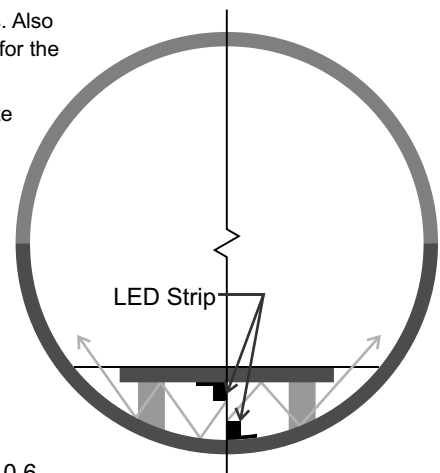
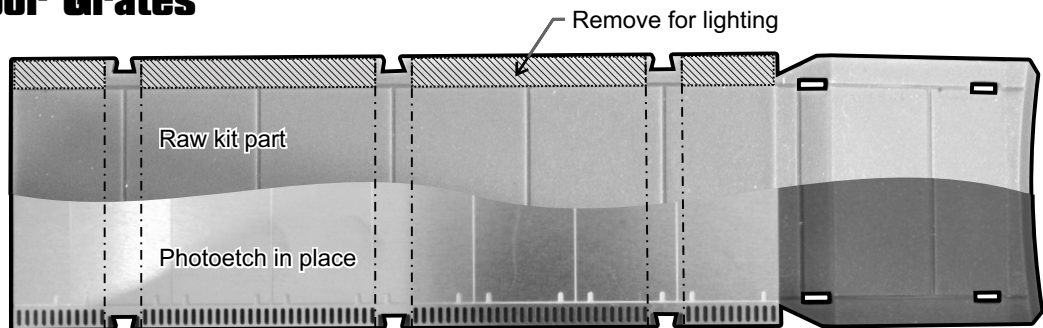

Cockpit Corridor

Flooring

Mount the photoetched flooring (etch parts 10 and 11) as shown. Note that 10 fits between the wall mounting holes. OPTIONAL: Mount the grill, 6, to the stair riser – this piece is inaccurate, but is included to make the inaccurate kit riser look more like those in the hold.

Control Panels

Mount the control panels 7, 8, and 9 as shown and attach their decals (once the etch is painted). Micro Krystal Klear, Testors Clear Parts Adhesive or a similar product if you remove plastic behind the etch for lighting. You may use the templates below to help position the back wall details.

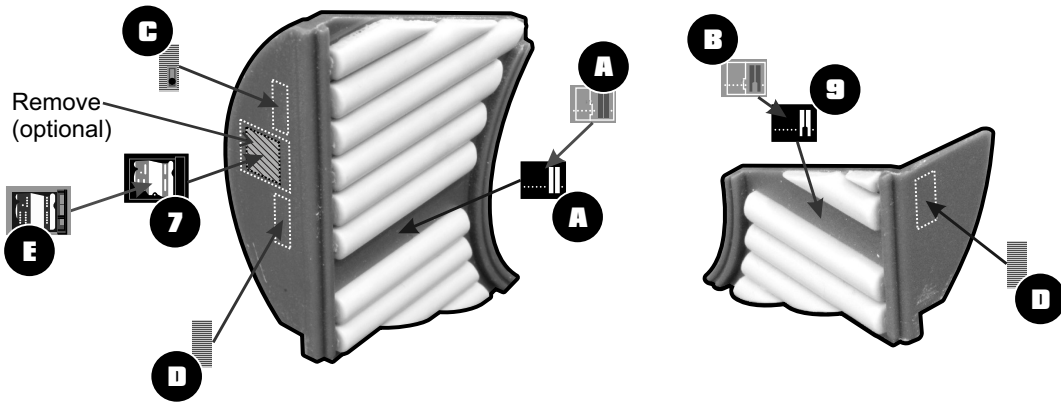
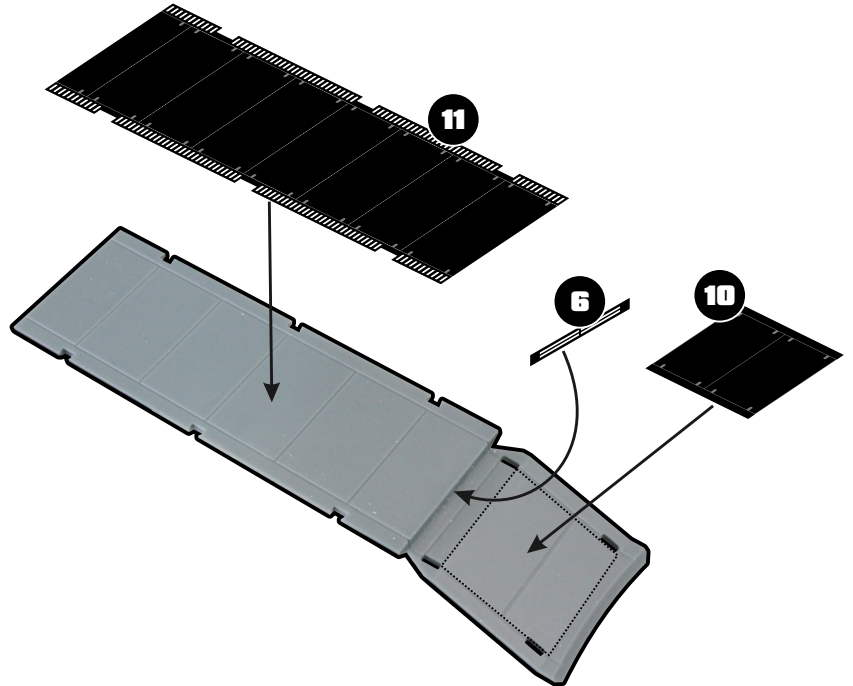

Templates

Feel free to photocopy these templates rather than

You can also download these templates at:

http://www.paragrafix.biz/instructions/PGX197_TEMPLATES.pdf

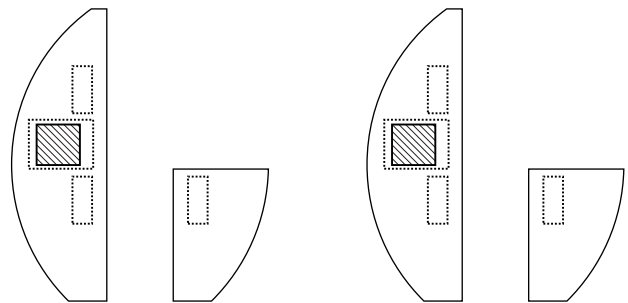

Main Corridor Flooring

Smuggling Pits (Optional)

Note that the scribed panels on the kit flooring does not match that on the photoetched flooring. This means that the smuggling pits (where our heroes hid upon landing in the Death Star) do not line up with the kit's floor panels.

Use the photoetch as a template to mark the locations of the two pits. Remove the plastic from this area.

Mounting Flooring

BE CAREFUL: Note that the hold end of each photoetch part extends past the kit's plastic piece. Until the corridors are mated to the hold be careful to avoid damaging these overhanging parts.

Attach etch parts 1 and 5 to the main corridor and extension corridor flooring pieces as shown below, then assemble the corridors as described in the kit's instructions.

Smuggling Pit Hatches

Note that there are two sets of smuggling pit covers (etch parts 3 and 4).

Parts 3 do not have any material removed from their back side and are intended to be mounted separately from the main floor to show the hatch(es) open.

Parts 4 have relief corresponding to the lip on the floor. This allows the hatches to be installed flush to the rest of the floor sections so that there is no visual indication that they're any different.

Which cover(s) you install is up to you.

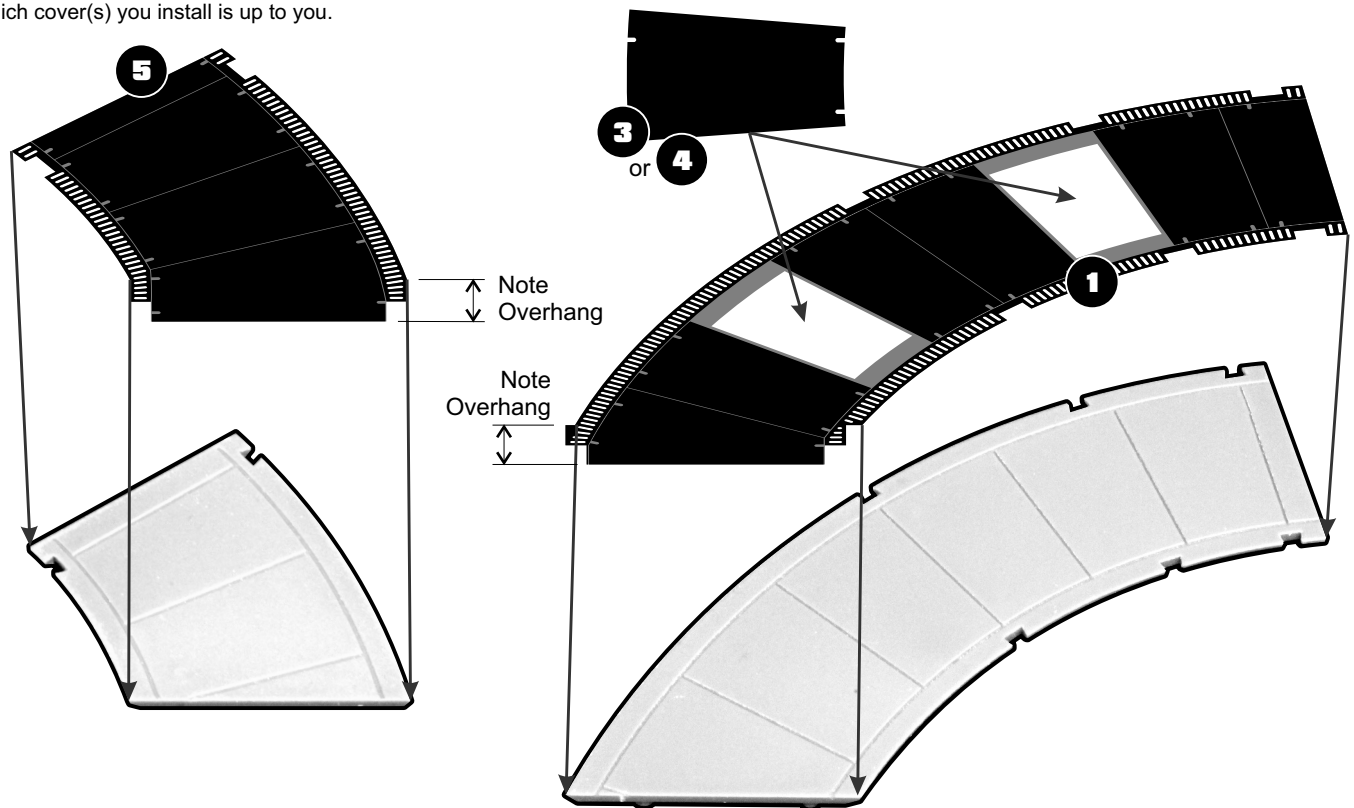

Hold Step Risers

Once the corridors are permanently attached to the hold, install etch parts 12 and 13 at the base of the entry rings. Part 12 goes on the main corridor and 13 mounts over the extension corridor's ring.

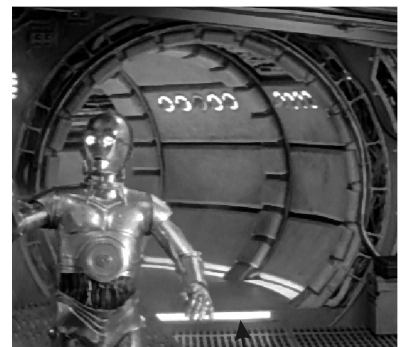

Wall Sconces

NOTE: Because of compromises that had to be made, the hallways don't exactly match those of the full sized set. The following is a suggested layout for the wall sconces, but please do not feel that they are cast in stone and feel free to be creative with the number you add in each section.

To add a more accurate, 3D appearance, mount a 1/16" (1.5mm) long piece of rod or tube* to each wall sconce piece (etch parts 2) as shown at right. As you can see in the photo insert, the extension tapers - you can duplicate this using multiple diameters of tubing or by modifying a piece of rod or tube.

Mount the sconces in the positions shown below and to the right. The positions are approximate as noted above. Some notes: A) There are only 5 lights on the set. B) There is only 1 on the set. C) This section of the set is long and uses 5. D) Each section D has 5 sconces on the set.

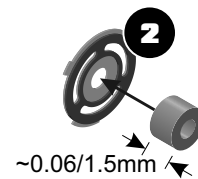
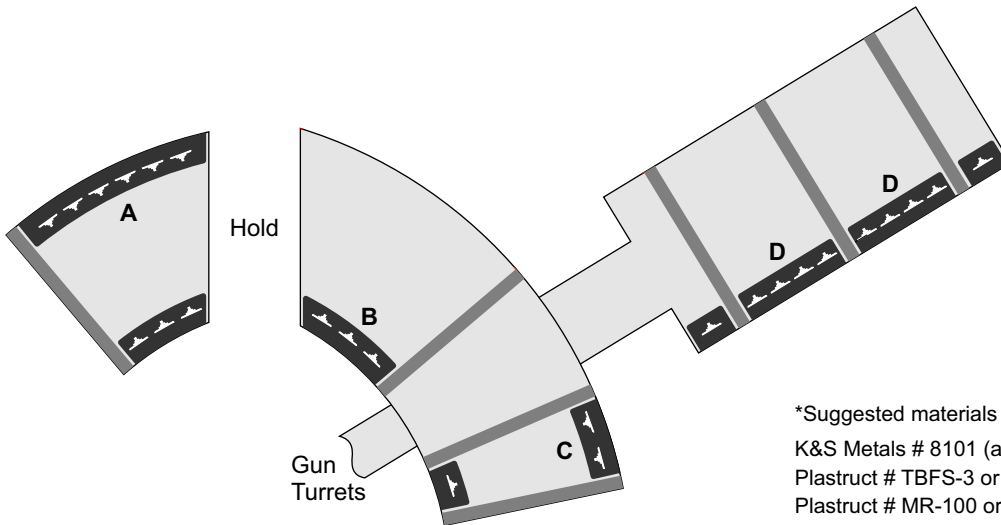
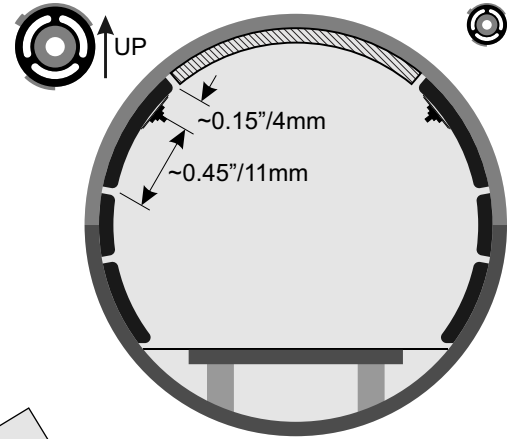

*Suggested materials (only largest size given):

K&S Metals # 8101 (aluminum) or # 8126 (brass)

Plastruct # TBFS-3 or Evergreen #223 plastic tubing

Plastruct # MR-100 or Evergreen #213 plastic rod

DECAL INSTRUCTIONS

Decals are best applied to a glossy surface. Apply glossy paint or spray a clear gloss coating on your model before applying decals. Carefully cut out the decal from the sheet and, using tweezers, dip the decal into plain water for 5 seconds or until the blue backing changes to a darker blue.

WARNING:

Leaving the decal in the water too long may result in the glue washing off the decal. Lay the decal on your work surface for 30 seconds, and then slide the decal off the backing paper into position on your model. Gently blot the excess water. Allow to dry. Once the decals have dried thoroughly, you can use a sharp knife to gently cut and remove the excess decal film. Apply a second coat of clear finish over the model to seal the decals.

A decal set may be used to help the decal conform to irregular surfaces and hides the decal film. This makes the artwork appear to be painted on the model, rather than applied by decal. Another method used is to create an equal mixture of water and white glue (Elmer's). Using a brush, apply the mixture to the surface. While still wet, apply the decal. The glue will help the decal adhere to the surface and will dry clear. Once dry, wet a Q-tip and remove any excess glue from the model and decal by brushing out from the center of the decal. Brushing into the center may cause the decal edge to lift.

Important: Please Read

The JT-Graphics decals you have purchased are coated with Testor's Clear Flat Lacquer. Using an Enamel clear coat such as Krylon or Rustolium may cause damage to the decal.

A known fact is that you can apply lacquer over enamel, but not enamel over lacquer. Therefore, it is suggested that after applying the decals, you only coat (seal) your model with a lacquer clear coat to avoid damaging the decals. Acrylic enamel may not react to the lacquer, but it has not been tested. Another suggestion is to use a piece of the decals, (such as the JT-Graphics logo or an optional decal you do not plan on using) and test it. Apply your test decal to a painted surface similar to the one you will be applying to and test it against the clear coat you wish to use.

Besides using Testor's Clear lacquer as a sealer, you can also use Future Floor Wax as a clear coat.

Any problems or Questions contact:

Jeffrey Waclawski 410-574-3220

info@jt-graphics.com

JT-GraphicsTM
.com

**PARA
GRAFIX**TM

104 County Street, Suite 101
Attleboro MA 02703 USA
+1 508-431-9800
www.ParaGrafix.biz