

# mpc

## STARWARS

### DARTH VADER

### T.I.E. FIGHTER

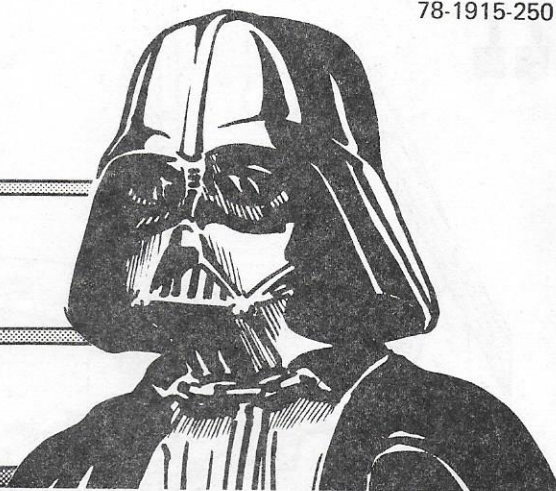

**IMPORTANT INSTRUCTIONS:** Before beginning assembly read the instructions through, and test fit the parts without cementing. This will familiarize you with the location of parts, eliminating errors. It is best to use a modeler's knife for removing parts from the "runners", instead of twisting them off. Trim off excess plastic or "Flash", and scrape paint from parts where they join other parts before cementing. MPC models are made of the highest quality styrene plastic, so only paint and cement made for styrene should be used. To join parts, use cement sparingly, being careful not to get cement on exposed surfaces. Apply cement with a toothpick to small parts. When painting the model, it is easier to cement all colored parts and paint the whole unit at one time. You should have no trouble assembling your kit if you follow the instructions. May the force be with you!

Assembly Guide	Part Numbers	Assembly Sequence		Cement <span style="border-bottom: 1px dashed black; display: inline-block; width: 50px;"></span> →
	Colored 1 to 45 CLEAR WINDOW	Colored (6)	Clear (7)	Do not cement <span style="border-bottom: 1px solid black; display: inline-block; width: 50px;"></span> →

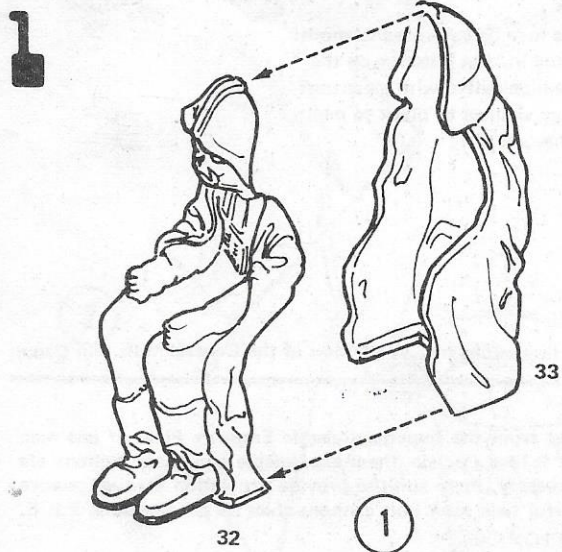

**PAINT:**  
Suit & Cloak - Flat Black  
Helmet & Boots - Black

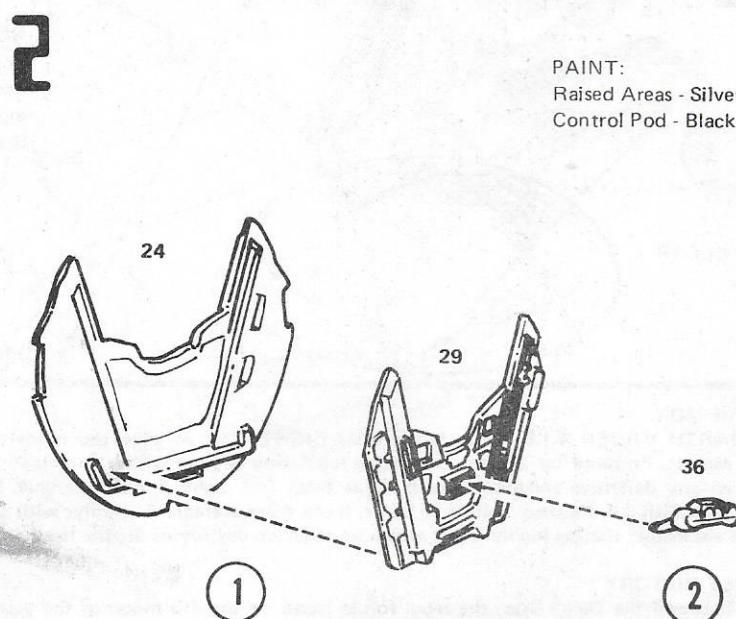

**PAINT:**  
Raised Areas - Silver  
Control Pod - Black



3

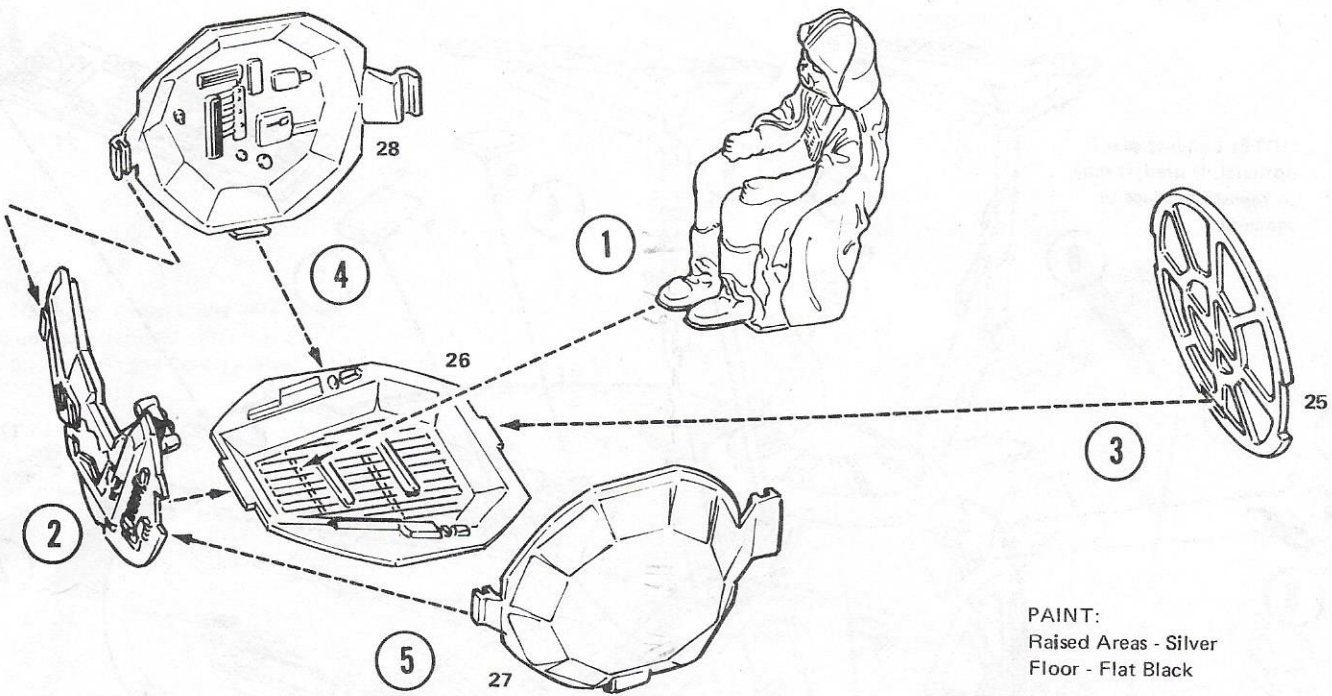

PAINT:  
 Raised Areas - Silver  
 Floor - Flat Black

4

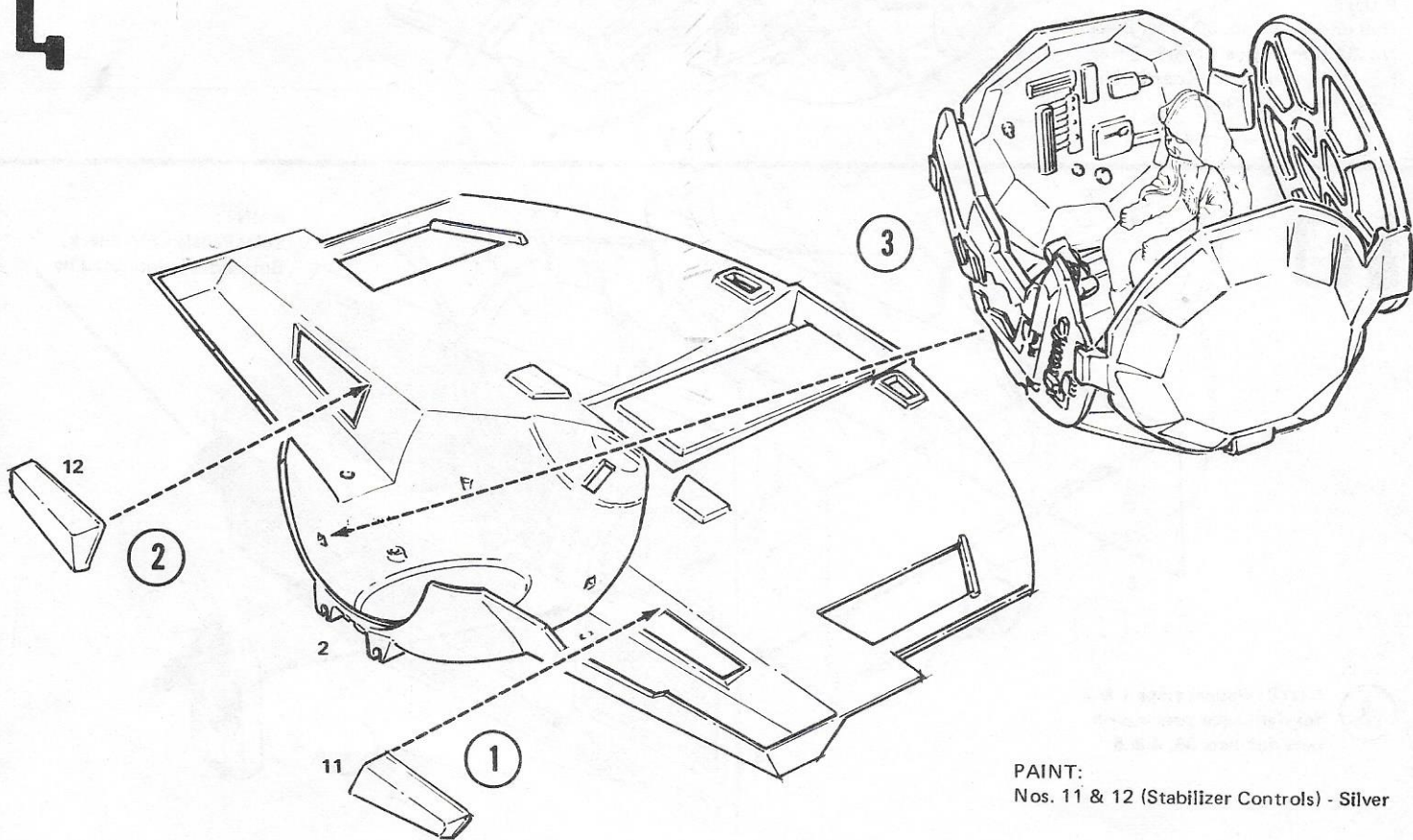

PAINT:  
 Nos. 11 & 12 (Stabilizer Controls) - Silver



# 5

CLEAR WINDOW

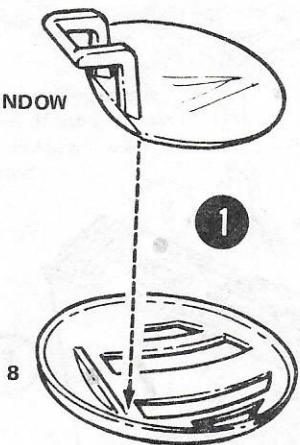

# 6

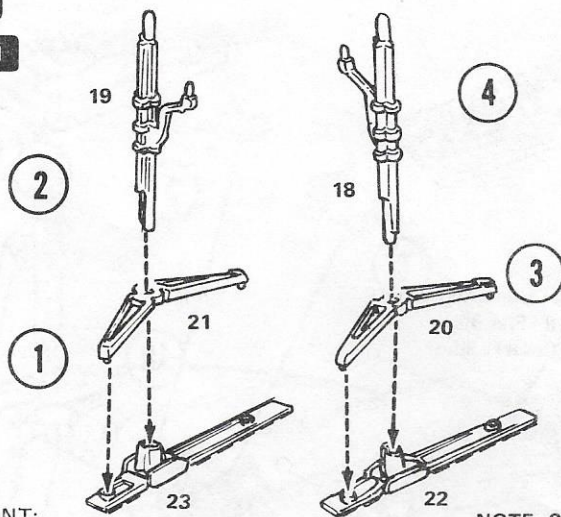

PAINT:  
Nos. 18 & 19 (Gear Struts) - Silver

NOTE: Save optional landing gear for step 9.

# 7

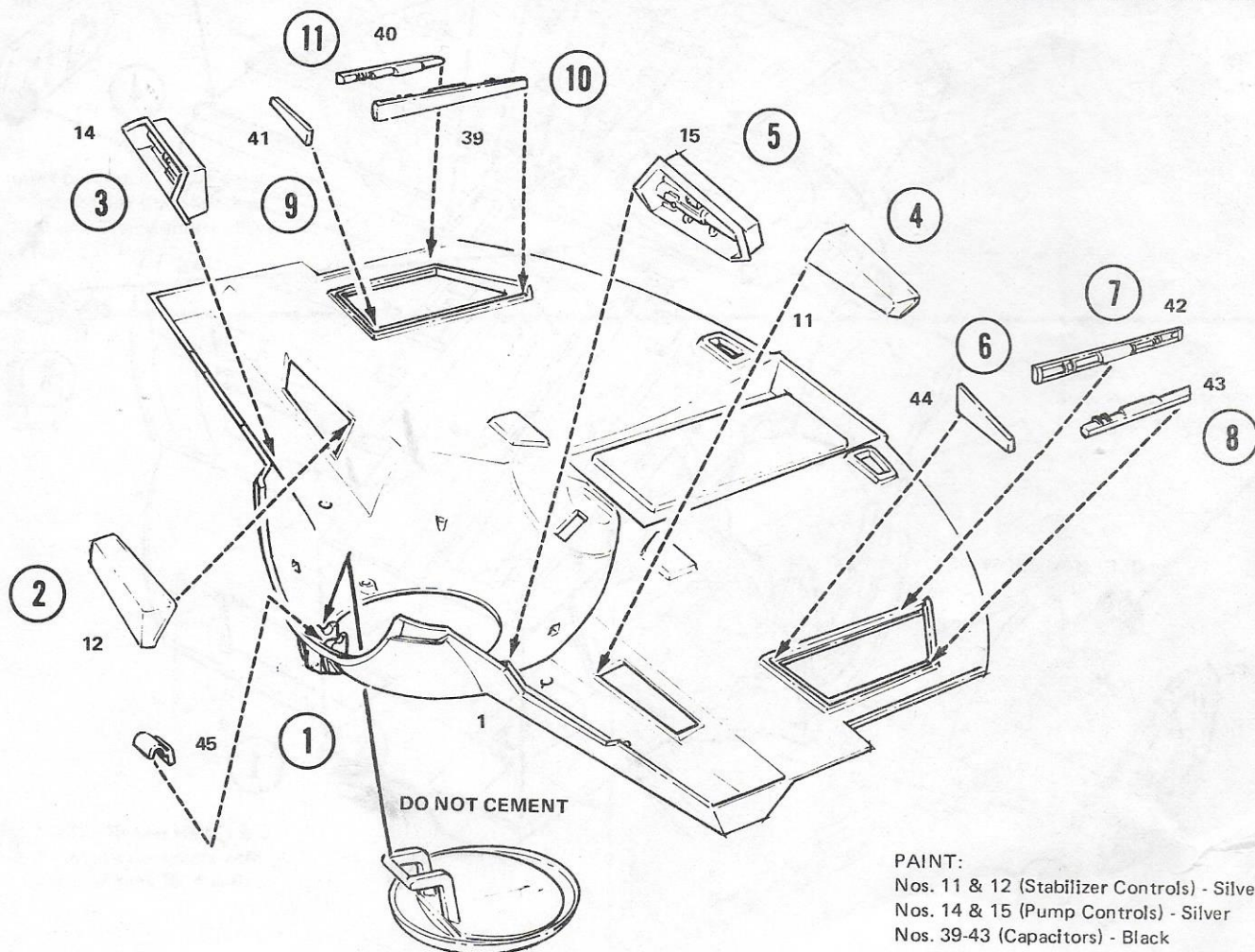

PAINT:  
Nos. 11 & 12 (Stabilizer Controls) - Silver  
Nos. 14 & 15 (Pump Controls) - Silver  
Nos. 39-43 (Capacitors) - Black



PAINT:  
No. 10-Engine Thrust Cover - Flat Black  
Hull under part no. 30 - Flat Black  
No. 30 - (Ion Engine Cover) - Silver

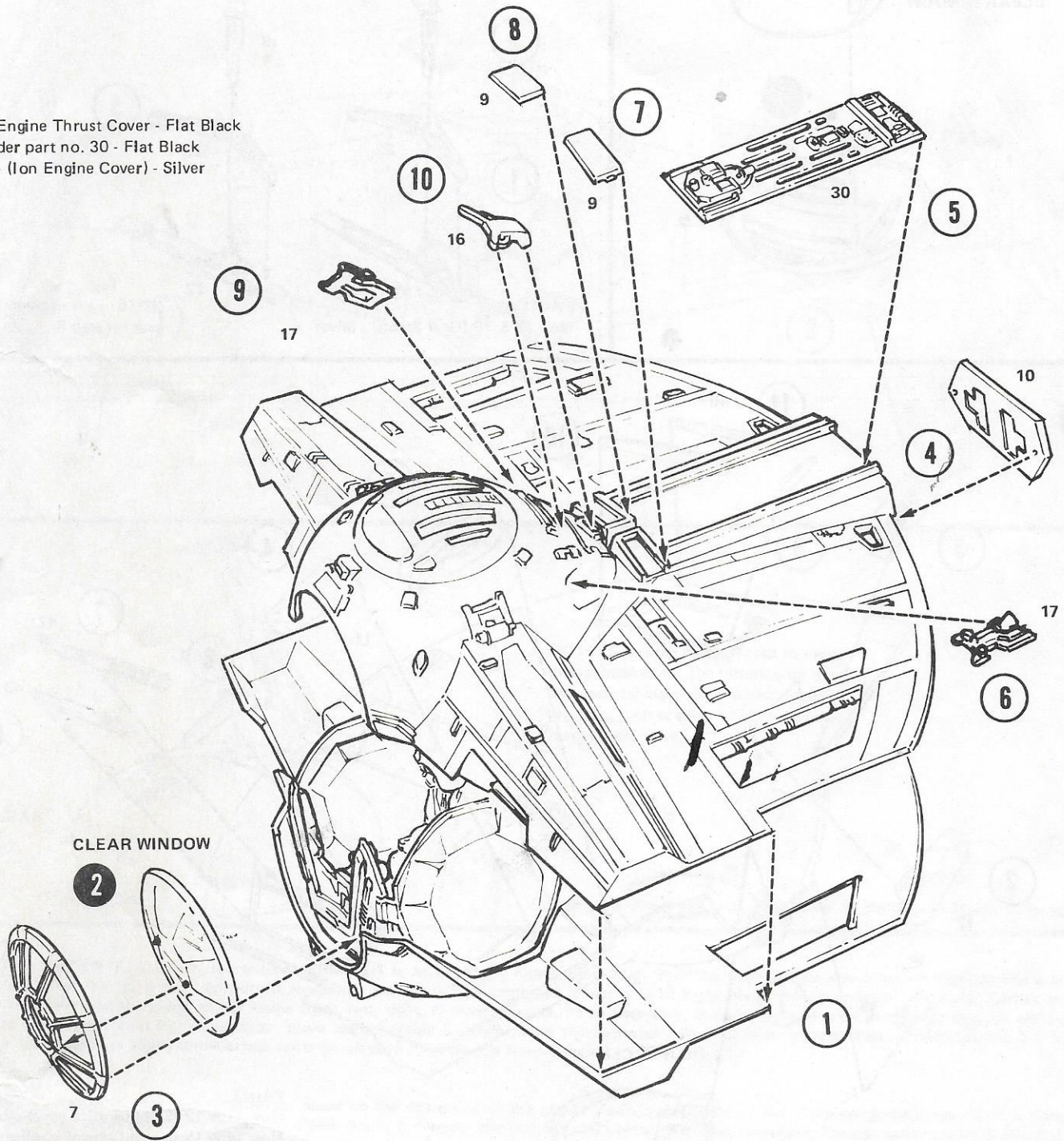



# 9

NOTE: Landing gear is optional. If used, it may be pressed in place or cemented.

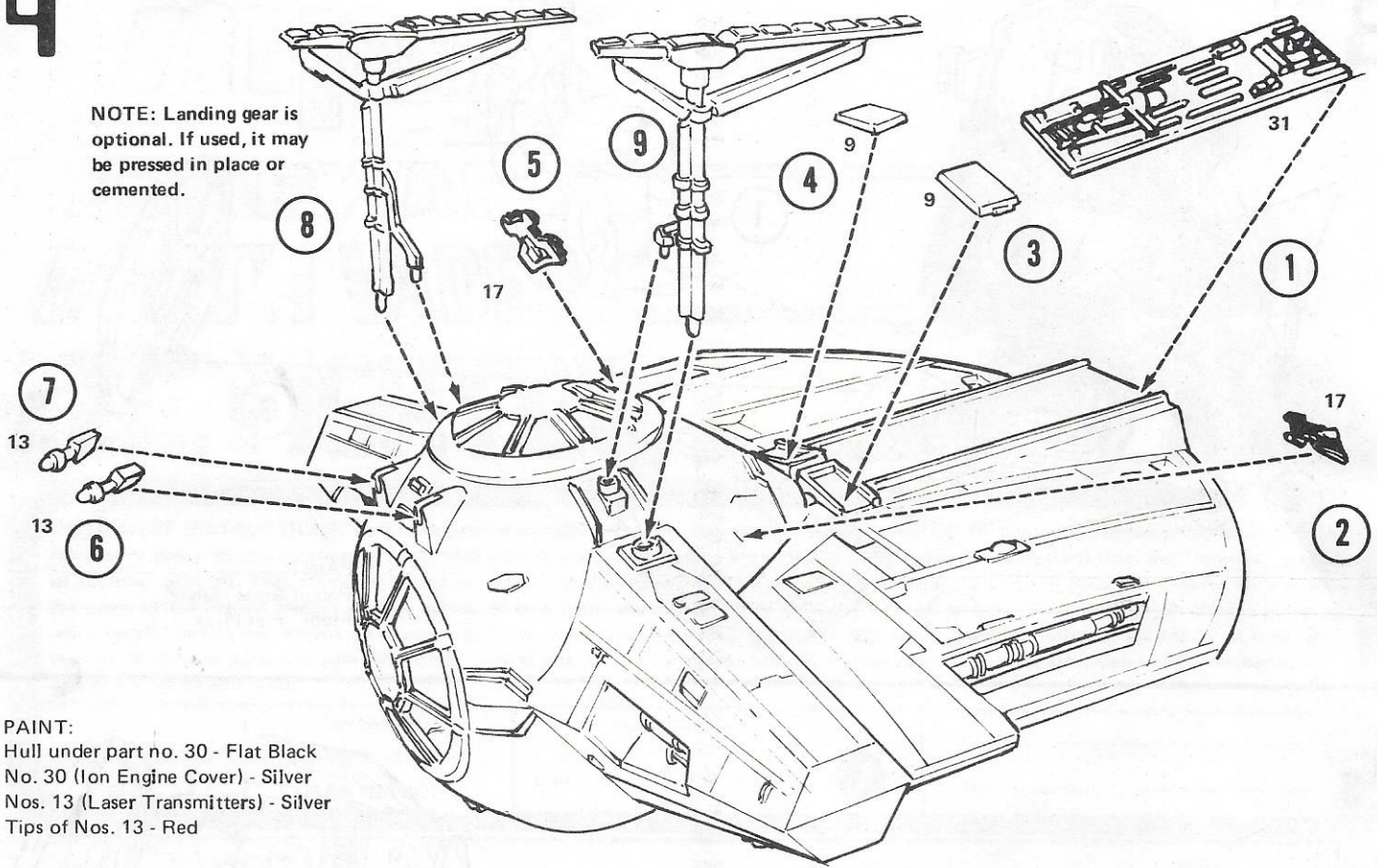

PAINT:  
Hull under part no. 30 - Flat Black  
No. 30 (Ion Engine Cover) - Silver  
Nos. 13 (Laser Transmitters) - Silver  
Tips of Nos. 13 - Red

# 10

PAINT:  
Solar Panels - Flat Black,  
Both sides as indicated by

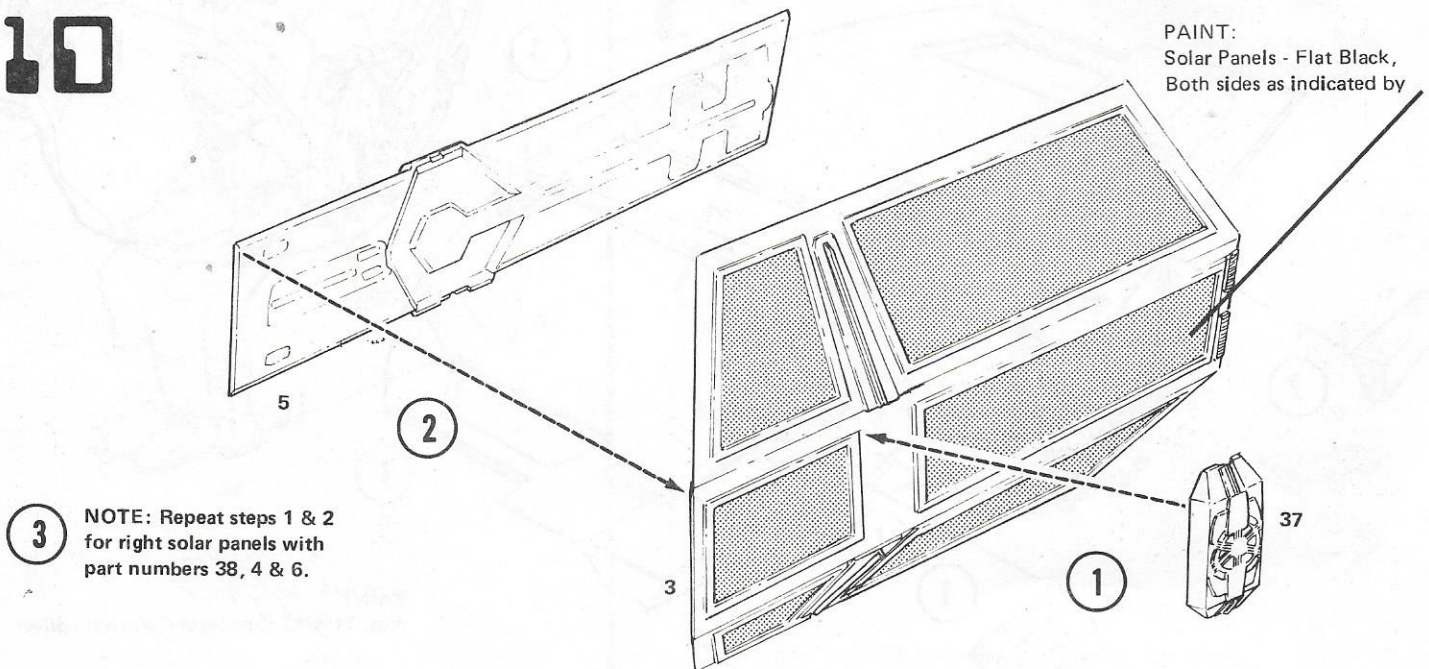

NOTE: Repeat steps 1 & 2  
for right solar panels with  
part numbers 38, 4 & 6.



11

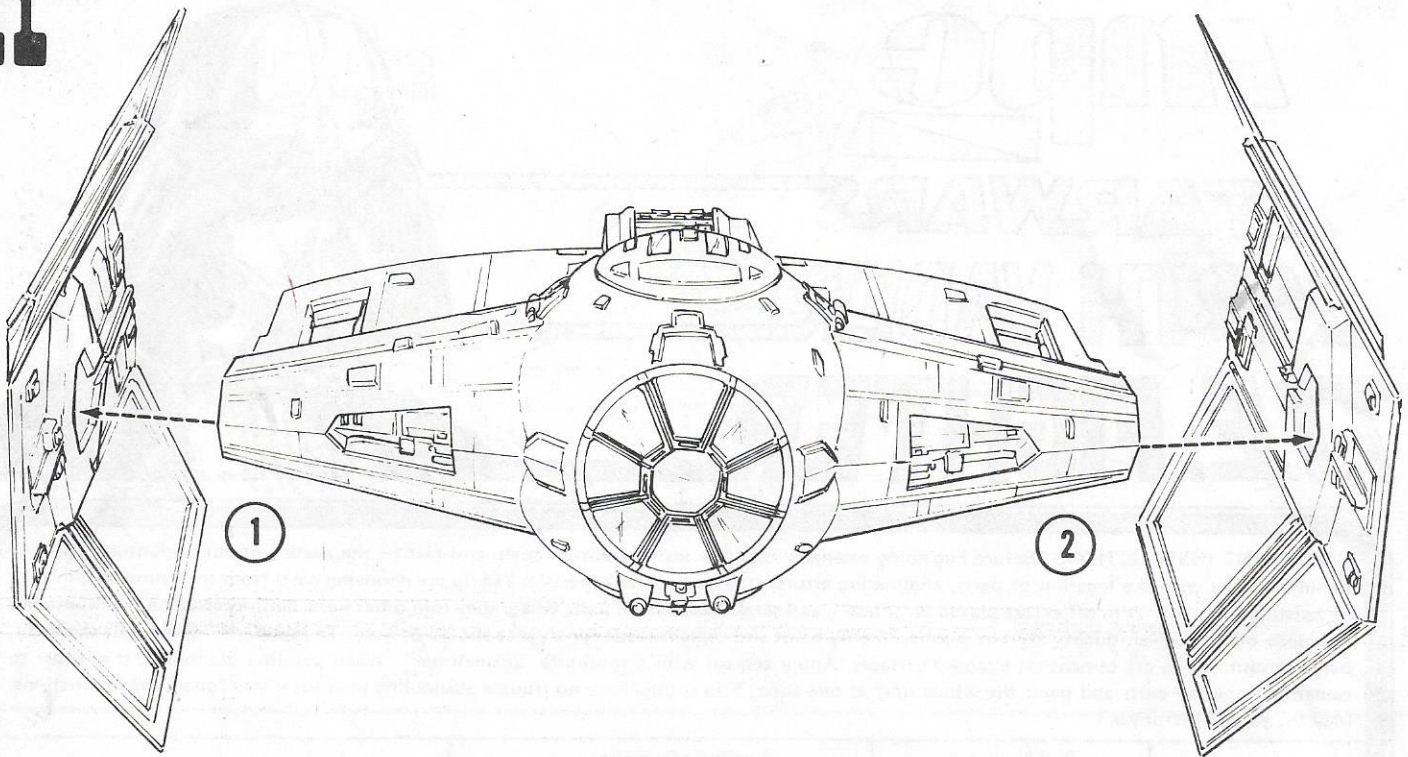

12

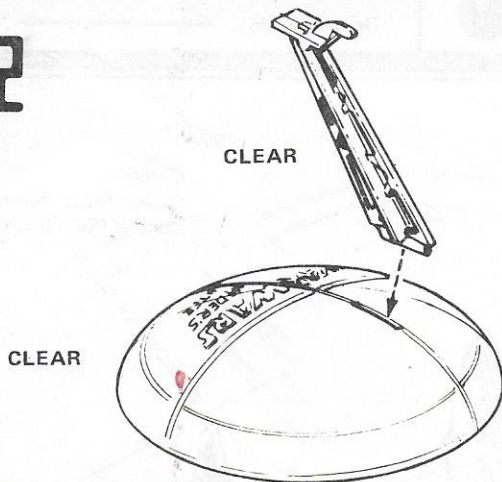

NOTE: Base may be cemented to model or just hooked in. The lettering on the base may be highlighted with a contrasting paint such as silver or black to make it stand out more.

© 1978 Fundimensions Inc., A Division of the General Mills Fun Group

#### DESCRIPTION

THE DARTH VADER T.I.E. (twin ion engine) FIGHTER is an advanced model developed from the Imperial Galactic Empire's Fleet of one man attack escorts. Powered by 2 solar converting ionization engines, with a combined thrust of 9.15 Kg/parsic, these expendable and cheap fighters are not given any defensive shielding, which keeps them fast, light, & maneuverable. When necessary, these abilities provide protection through evasive action. The Sith Lord's own fighter is faster, more maneuverable & deadly, with the powerful twin laser bolt cannons than its predecessors. T.I. E. fighters are mainly used as highly lethal attack units which destroy or disable fleeing craft.

#### PROFILE HISTORY

In the Battle of the Death Star, the rebel forces based on the 4th moon of the planet Yavin, sent a fleet of one man/one droid Incom, T-65, X-Wing fighters with 4 ion rocket engines to attack the Death Star's vulnerable thermal exhaust port with proton torpedoes. Though better armed & shielded, they were all but devastated when Luke Skywalker in blue unit five was making his run down the equatorial trench. Darth Vader was closing in for the kill, when one of his wingmen was vaporized by an energy bolt from Hans Solo's Millennium Falcon. This explosion threw the other wingman into Vader's ship severely damaging it & throwing it out of control to spin off into space just before the Death Star turned into a Super Nova.